

Courtesy translation, not binding.

REGASIFICATION CODE

Offshore Regasification Terminal

of

Terminale GNL Adriatico S.r.l.

CONTENTS

CHAPTER I GENERAL PRINCIPLES	11
<i>I.1 DEFINITIONS AND INTERPRETATION</i>	<i>11</i>
I.1.1 Definitions	11
I.1.2 Interpretation	27
<i>I.2 LIST OF ANNEXES</i>	<i>28</i>
<i>I.3 APPLICABLE LAW</i>	<i>29</i>
<i>I.4 RESOLUTION OF DISPUTES</i>	<i>29</i>
I.4.1 Competence of the Regulatory Authority for Electricity and Gas	29
I.4.2 Submission to jurisdiction	29
I.4.3 Arbitration of Technical Disputes	29
CHAPTER II TERMINAL SPECIFICATIONS, ACCESS PROCEDURES AND SCHEDULING	31
<i>II.1 DESCRIPTION OF THE PLANT AND SYSTEMS</i>	<i>31</i>
II.1.1 Terminal specifications	31
<i>II.2 CAPACITY</i>	<i>33</i>
II.2.1 Calculation of the Terminal Capacity	33
II.2.2 Spot Capacity	34
II.2.3 Posting of Terminal Capacity	35
II.2.4 Subscription of the Terminal Capacity	36
II.2.5 Access denial	46
II.2.6 Released Capacity	48
II.2.7 Subscribed Non-Foundation Capacity to be made available to the Operating Company for allocation to third parties pursuant to article 11, sub-section 3, of AEEG Resolution no. 167 of 1 August 2005	49
II.2.8 Subscribed Foundation Capacity to be made available to the Operating Company for allocation to third parties pursuant to article 6, sub-section 3, of the MAP decree of 11 April 2006	51
<i>II.3 SCHEDULING OF UNLOADING SLOTS</i>	<i>51</i>
II.3.1 General principles	51
II.3.2 Annual Scheduling	52
II.3.3 Three (3) Month Scheduling	53
II.3.4 Spot Cargo scheduling	55
II.3.5 Planning and management of maintenance and inspections	55
II.3.6 Amendments to schedules	57
II.3.7 Unloading Slot unavailability	57
II.3.8 Additional services	59
CHAPTER III GENERAL TERMS AND CONDITIONS FOR PROVISION OF THE SERVICE	61
<i>III.1 CAPACITY AGREEMENTS</i>	<i>61</i>
<i>III.2 SCOPE OF CAPACITY AGREEMENTS AND OBLIGATIONS OF THE PARTIES</i>	<i>61</i>
III.2.1 Scope of Capacity Agreements	61
III.2.2 Parties' obligations	61
III.2.3 Service Conditions	63
III.2.4 User's representations and warranties	64
III.2.5 Operating Company's standard of performance	66
III.2.6 User's standard of performance	66

III.2.7	Refusal of changes in the Service	66
III.2.8	Performance of the Regasification Service	66
III.2.9	Performance of the Redelivery Service	66
<i>III.3</i>	<i>RIGHT OF WITHDRAWAL</i>	<i>67</i>
III.3.1	Withdrawal by Users	67
III.3.2	Payment upon User withdrawal	67
<i>III.4</i>	<i>TITLE</i>	<i>68</i>
III.4.1	Title to LNG	69
III.4.2	No transfer of title in LNG or resultant Gas	69
III.4.3	Right to co-mingle	69
<i>III.5</i>	<i>QUANTITY AND QUALITY OF LNG</i>	<i>69</i>
<i>III.6</i>	<i>QUANTITY, QUALITY AND PRESSURE OF GAS</i>	<i>72</i>
III.6.1	Redelivery of Gas	72
III.6.2	Losses and Consumption	78
III.6.3	The correction of the measurement uncertainty	78
<i>III.7</i>	<i>FORCE MAJEURE</i>	<i>79</i>
III.7.1	Meaning of Force Majeure	79
III.7.2	List of Force Majeure Events	79
III.7.3	Relief for Force Majeure	80
III.7.4	Action to be taken on Force Majeure	80
III.7.5	Termination for extended Force Majeure	82
III.7.6	Exclusivity of Force Majeure provisions	83
III.7.7	Force majeure declared by the counterparties of import contracts	83
<i>III.8</i>	<i>INVOICES, PAYMENT AND CAPACITY MAKE-UP</i>	<i>84</i>
III.8.1	Invoicing by the Operating Company	84
III.8.2	Due date for invoices	89
III.8.3	Payment Instructions	90
III.8.4	Suspension of payment of invoices	90
III.8.5	Default interest	90
III.8.6	Adjustment of Errors	90
III.8.7	No deduction of taxes; liability for Maritime Charges	91
III.8.8	Adjustments to the applicable tariffs	91
III.8.9	Annual Reconciliation Calculation	91
III.8.10	Capacity Make-Up	93
III.8.11	Charges for scheduling variance applicable to Continuous Users	94
III.8.12	Charges for scheduling variance applicable to Spot Capacity	95
III.8.13	Invoicing of scheduling variance charges	95
III.8.14	Invoicing of Losses and Consumption	95
III.8.15	Invoicing of quantities of gas to be paid in kind to the transportation company to cover the needs of consumption, network and gas losses.	95
<i>III.9</i>	<i>TAXES, DUTIES AND CHARGES ON THE GAS</i>	<i>96</i>
III.9.1	Fiscal Compliance	96
III.9.2	Liability for tax obligations	96
III.9.3	Payment of duties, and taxes (including VAT)	96
III.9.4	Administrative Documentation	97
<i>III.10</i>	<i>GUARANTEES</i>	<i>97</i>
III.10.1	Financial security for User's obligations	97
III.10.2	First Demand Parent Company Guarantee	99

Courtesy translation, not binding.

III.10.3	First Demand Guarantee	99
III.10.4	Replacement of and calls on First Demand Guarantee	100
III.10.5	Signing authorities	101
III.10.6	Application of clause 10 to Spot Capacity Applicants and Users	101
<i>III.11</i>	<i>INSURANCE</i>	<i>101</i>
III.11.1	Operating Company insurance	101
III.11.2	User insurance	101
<i>III.12</i>	<i>EXCHANGES OF SUBSCRIBED CAPACITY AND TRANSFERS OF SUBSCRIBED FOUNDATION CAPACITY</i>	<i>101</i>
III.12.1	Exchanges of Subscribed Capacity	101
III.12.2	Transfers of Subscribed Foundation Capacity	103
<i>III.13</i>	<i>TERMINATION</i>	<i>104</i>
III.13.1	Termination by the Operating Company	104
III.13.2	Withdrawal by the Operating Company	104
III.13.3	Accrued rights	105
III.13.4	Waiver of Italian civil code rights	105
<i>III.14</i>	<i>LIABILITY</i>	<i>105</i>
III.14.1	Limitation of liability	105
III.14.2	Payment upon Operating Company termination	106
III.14.3	User indemnity for Damaging Events	107
III.14.4	No actions amongst Users	108
III.14.5	Environmental indemnity from Users	108
<i>III.15</i>	<i>COMPLAINTS</i>	<i>108</i>
III.15.1	Inspections of the Service	108
III.15.2	Complaints	109
III.15.3	Supporting documentation for complaints	109
III.15.4	Restriction on bringing complaints	109
<i>III.16</i>	<i>DOMICILE AND NOTICES</i>	<i>109</i>
III.16.1	Service of notices	109
III.16.2	Domicile for notice purposes	110
<i>III.17</i>	<i>WAIVER</i>	<i>110</i>
<i>III.18</i>	<i>CONFIDENTIALITY</i>	<i>110</i>
III.18.1	No disclosure of confidential information	110
III.18.2	Liability for disclosure of confidential information	110
III.18.3	Exceptions to confidentiality	110
III.18.4	Duration of confidentiality obligations	111
III.18.5	Compliance with confidentiality laws	111
III.18.6	Statement of information under the applicable data protection Regulations	112
<i>III.19</i>	<i>ENFORCEMENT COSTS</i>	<i>112</i>
<i>III.20</i>	<i>WAIVER OF IMMUNITY</i>	<i>112</i>
	CHAPTER IV ACCESS OF LNG TANKERS TO THE TERMINAL	114
<i>IV.1</i>	<i>LNG TANKERS</i>	<i>114</i>
IV.1.1	LNG Tankers requirements	114
IV.1.2	Acceptance of LNG Tankers	114
IV.1.3	Rejection of LNG Tankers	115
IV.1.4	Modifications to LNG Tankers	115
<i>IV.2</i>	<i>NOTICES</i>	<i>116</i>

Courtesy translation, not binding.

IV.2.1	Departure notice	116
IV.2.2	Forty-eight (48) hours advance notice	117
IV.2.3	Twenty-four (24) hours advance notice	117
IV.2.4	Arrival notice	118
IV.2.5	Notice of Readiness	118
<i>IV.3</i>	<i>ARRIVAL AND UNLOADING OF LNG TANKERS AT THE TERMINAL</i>	<i>118</i>
IV.3.1	Procedures for LNG Tankers	118
IV.3.2	On-Time Arrival	119
IV.3.3	Early Arrival	119
IV.3.4	Late Arrival	120
IV.3.5	Delays	120
IV.3.6	Re-Assignment of Berth	121
IV.3.7	Completion of Unloading	121
IV.3.8	Laytime and Demurrage	121
IV.3.9	Excess Boil-off	123
	CHAPTER V MANAGEMENT OF SERVICE EMERGENCIES	124
<i>V.1</i>	<i>INTRODUCTION</i>	<i>124</i>
<i>V.2</i>	<i>SERVICE EMERGENCIES</i>	<i>124</i>
V.2.1	Types of emergency	124
V.2.2	Levels of emergency	124
V.2.3	Objectives of intervention	125
V.2.4	Description of the emergency alarm system	125
<i>V.3</i>	<i>EMERGENCY FOR NON SCHEDULED OUT OF SERVICE</i>	<i>126</i>
<i>V.4</i>	<i>INFORMATION IN RELATION TO EMERGENCIES</i>	<i>126</i>
	CHAPTER VI AMENDMENT OF THE REGASIFICATION CODE	127
<i>VI.1</i>	<i>GENERAL PRINCIPLES</i>	<i>127</i>
VI.1.1	Automatic modification for mandatory rules	127
VI.1.2	Amendments	127
<i>VI.2</i>	<i>REQUESTS FOR THE AMENDMENT</i>	<i>128</i>
VI.2.1	Subjects entitled to submit requests for the amendment of the Regasification Code	128
VI.2.2	Requirements for the admissibility of the requests	128
VI.2.3	Declaration of admissibility	128
VI.2.4	Assessment of the request	129
<i>VI.3</i>	<i>PROPOSALS FOR THE AMENDMENT OF THE REGASIFICATION CODE</i>	<i>129</i>
VI.3.1	Preparation of the proposals for the amendment	129
VI.3.2	Consultation on the proposed amendment	130
VI.3.3	Filing with the Regulatory Authority for Electricity and Gas of the proposal for amendment	130
<i>VI.4</i>	<i>COMMUNICATIONS</i>	<i>131</i>
	CHAPTER VII QUALITY OF THE SERVICE	132
Annex (a)	Form of Access Request for all Capacity Agreements other than for any Foundation Capacity Agreement	137
	Part I Form of Access Request for all Capacity Agreements other than for any Foundation Capacity Agreement	141
	Part II Form of Access Request for Capacity Make-Up	144

Courtesy translation, not binding.

	Part III	Form of Modified Acceptance for Non-Foundation Capacity Agreement	147
	Part IV	Non-Foundation Capacity Agreement	149
	-	Schedule (1)	154
	-	Schedule (2) Direct Agreement	155
	-	Exhibit A to Direct Agreement - The Finance Parties	161
	-	Exhibit B to Direct Agreement - Payment instructions for Account	162
	Part V	Spot Capacity Agreement	163
	-	Schedule (1)	168
Annex (b)	Part I	Form of undertaking to issue a First Demand Guarantee	169
	Part II	Form of First Demand Guarantee	171
	-	Appendix A Form of Demand	177
	-	Appendix B Form of notification of the Amount	178
Annex (c)		Form of First Demand Parent Company Guarantee	179
Annex (d)		Requirements for the Terminal Insurance Policy and User Insurance Policy	182
Annex (e)		Form of Release Declaration	183
Annex (f)		Form of Reclaim Declaration	184
Annex (g)		Definition of and method for calculation of Net Present Value	185
Annex (i)		Gas Quantity, Quality and Pressure Specifications	186
Annex (k)		Testing and Measuring Methods	190
Annex (l)		Location of the Terminal	211
Annex (m)		Plan	212
Annex (n)		Description of berthing facilities	213
Annex (o)		Additional Services: Flexibility Service and Temporary Storage Service	221

REGASIFICATION CODE

RECITALS

WHEREAS **Terminale GNL Adriatico S.r.l.**, with registered office at Piazza della Repubblica 14/16, 20124 Milan, and registered with the Milan *Registro delle Imprese* under no. 1788519, VAT and tax code no. 13289520150 (hereinafter the "**Operating Company**") is in the process of implementing a project to build and operate the Terminal, it being intended that the Terminal is expected to start its commercial activities in the first quarter of 2009;

WHEREAS article 24 of the Decree requires that access to LNG terminals shall be regulated by an Regasification Code issued by the operating companies in compliance with criteria set and approved by the Regulatory Authority for Electricity and Gas; and

WHEREAS the general principles to determine the applicable tariff which may be charged by operating companies for the use of LNG terminals have been settled by the AEEG Resolution no. 120 of 30 May 2001, as amended by the AEEG Resolution no. 127 of 2 July 2002, the AEEG Resolution no. 144 of 5 August 2004, the AEEG Resolution no. 5, the AEEG Resolution no. 6 of 18 January 2005 and the AEEG Resolution no. ARG/gas 92/08 of 7 July 2008, "Criteria for setting tariffs for the regasification services and amendments to resolutions no. 166/05 and no. 11/07";

PURSUANT TO THE FOLLOWING

articles 1 and 2, no. 12, letter (d) of law no. 481 of 14 November 1995, "Antitrust provisions and the regulation of utility services. The establishment of the Authorities for regulating utility services";

annex 1 of table A of law no. 448 of 23 December 1998, "Public financing measures for stabilisation and development";

directive 2009/73/EC of the European Parliament and of the Council of 13 July 2009 concerning common rules for the internal market in Gas and repealing directive 2003/55/CE, to be implemented in the Italian legislation by 3 March 2011;

article 41 of law no. 144 of 17 May 1999, "Investment measures, delegation to the Government to reform employment incentives and the regulations governing INAIL, as well as the provisions for social-security institution reform";

article 3, sub-section II, III, VI and IX, article 23, sub-section II and III, articles 24, 25, 26, 27, 30 and 35 of the Decree;

article 1, sections 17 and 18, of law no. 239 of 23 August 2004, "Reform of the energy sector and delegation to the Government for the reorganisation of the applicable energy laws and regulations";

section 2.3, the introduction to section 5 and section 5.3.2 of the Regulatory Authority for

Courtesy translation, not binding.

Electricity and Gas reference document of 24 October 2000, "Tariffs for the use of the National Gas System, LNG terminals and for the transport and storage of LNG", concerning the issue of provisions pursuant to article 23, sub-sections II and III of the Decree, and to article 2, sub-section XII, letters (d) and (e) of law no. 481 of 14 November 1995;

articles 1, 2, 3, 4, 5, 7, 8 and 9 of the MICA decree of 27 March 2001, "Determination of the criteria for the issuance of authorisations to import Gas from non-EU countries, pursuant to article 3 of legislative decree no. 164 of 23 May 2000";

MICA decree of 22 December 2000, "Identification of the national gas grid pursuant to article 9 of legislative decree no. 164 of 23 May 2000";

article 8 of law no. 340 of 24 November 2000, "Regulation for the reduction of provisions and for the simplification of administrative procedures – Simplification law of 1999";

article 26 of law no. 388 of 23 December 2000, "Provisions for the drawing up of the State annual and long-term budget";

chapter 2, section 3.3 and the introduction to chapter 4 of the Regulatory Authority for Electricity and Gas reference document of 13 March 2001, "Guarantees of free access to transport and dispatch activities: criteria for the drafting of network codes and obligations of entities performing such activities";

sections 5.1.3 and 5.3 of the Regulatory Authority for Electricity and Gas reference document of 13 March 2001, "Guidelines for the administrative and accounting separation of entities operating in the gas sector", being the reference document for the enactment of provisions pursuant to article 2 sub-section 12 letter (f) of law no. 481 of 14 November 1995;

article 2, sub-section II, article 3, sub-section IV and articles 4, 10, 11, 12, 13, 14 and 18 of the AEEG Resolution no. 120 of 30 May 2001, "Criteria for establishing tariffs for natural gas transportation and dispatch and for the use of liquefied natural gas terminals";

Customs Agency circular no. 24/D of 7 June 2001, "The introduction of the Euro as regards excise tax";

Customs Agency circular no. 1064 of 27 June 2001, "Legislative decree no. 164 of 23 May 2000 concerning the liberalisation of the internal gas market. Fulfilment of customs duties connected with imports, transit and exports";

AEEG Resolution no. 22 of 26 February 2004, "Provisions applying to the regulated market of capacity and gas, pursuant to article 13 of the Regulatory Authority for Electricity and Gas resolution of 17 July 2002, no. 137/02";

AEEG Resolution no. 68 of 18 April 2005, update of the "Agreement for the use of the system for exchange/transfer of gas at the Virtual Exchange Point" and of the document "System for the exchange/transfer of gas at the Virtual Exchange Point- PSV form", in relation to the regulated market of capacity and gas, pursuant to the AEEG Resolution no. 22 of 26 February 2004";

AEEG Resolution no. 167 of 1 August 2005, "Guarantees of free access to the liquefied natural gas regasification service and provisions for the drafting of regasification codes";

Courtesy translation, not binding.

MAP decree of 11 April 2006, “Procedures for the granting of exemptions from the third party access to new interconnections with European natural gas transportation networks and to new regasification terminals, and to their expansions as well as for the acknowledgement of priority allocation for new transportation capacity constructed in Italy, in relation to new interconnection infrastructures with States not belonging to the European Union”;

MAP decree of 28 April 2006, establishing, *inter alia*, (i) the procedures regulating access to the national gas grid, following the granting of an exemption to the third party access regime with regard to new regasification terminals and (ii) the criteria according to which the Regulatory Authority for Electricity and Gas will determine the procedure for the allocation of the residual quota of the regasification capacity which is not subject either to exemption or to priority allocation;

AEEG Resolution no. 168 of 31 July 2006, “Urgent provisions for the definition and allocation of the transportation capacity at entry points of the national grid interconnected with infrastructures which have benefited from an exemption and for the allocation of the residual capacity, pursuant to MAP decree of 28 April 2006”, as amended by AEEG Resolution no. 327 of 18 December 2007;

AEEG Resolution no. 204 of 27 September 2006, “Amendment to the discipline of the regulated market of capacity and gas, referred to under Regulatory Authority for Electricity and Gas resolution of 26 February 2004, no. 22/04, for the thermal year 2006-2007”; and

AEEG Resolution no. 245 of 28 September 2007, “Integrations to the discipline of the regulated market of capacity and gas, referred to under Regulatory Authority for Electricity and Gas resolution of 26 February 2004, no. 22/04, for the thermal year 2007-2008”.

AEEG Resolution no. ARG/Gas 184/09 of 12 January 2009 “Quality and tariff code for the natural gas transmission and dispatching services for the period 2010-2013”;

AEEG Resolution no. ARG/Gas 45/11 of 14 April 2011 “The discipline regarding the balancing of economic merit of natural gas”;

AEEG Resolution no. 297/2012/R/Gas of 19 July 2012 “Provisions on access to the natural gas transportation service at the entry and exit points interconnected with the storage or regasification terminals”;

AEEG Resolution 438/2013/R/gas of 9 October 2013 "Regulatory criteria for the regasification tariff of the liquefied natural gas for the period 2014-2017";

AEEG Resolution 502/2013/R/Gas of November 7 2013 "Provisions regarding the offer of the flexibility services from the regasification companies";

IN CONSIDERATION THAT

the environmental impact assessment procedure performed by the Ministry of the Environment was successfully completed with the issue of decree no. 4407 of 30 December 1999 confirming

Courtesy translation, not binding.

that the Terminal is environmentally compatible;

on 7 July 2000, MICA granted to Edison Gas the licence to install and operate an offshore terminal for the regasification of LNG together with two 125,000 m³ storage tanks, for a maximum aggregate storage capacity of 250,000 m³, in addition to the ancillary facilities and piping, and on 6 February 2002 Edison Gas has transferred to the Operating Company all the licences, permits and authorisations granted to Edison Gas in relation to the Terminal;

on 15 February 2010 the Operating Company submitted this Regasification Code to the Regulatory Authority for Electricity and Gas in order to permit the Regulatory Authority for Electricity and Gas to verify its compliance with the applicable regulations in force;

on 12 May 2011 the Regulatory Authority for Electricity and Gas, pursuant to article 24, sub-section V of the Decree, verified the compliance of the Regasification Code with the applicable regulations in force, particularly with regard to the criteria concerning the guarantee to all network users of open access on the same terms, absolute impartiality and neutrality in allowing use of the Terminal, which criteria are set forth in the provisions of the Decree; and

this Regasification Code is valid and has effect from the date of publication on the Italian Regulatory Authority for Electricity and Gas website;

**THEREFORE
THIS REGASIFICATION CODE IS IMPLEMENTED**

pursuant to article 24, sub-section V of the Decree.

CHAPTER I GENERAL PRINCIPLES

I.1 DEFINITIONS AND INTERPRETATION

I.1.1 Definitions

Except where the context requires otherwise, the following capitalised terms used in the Regasification Code shall have the meaning ascribed to them below:

"Acceptance" means, as the case may be, (a) acceptance by the Operating Company of an Access Request; or (b) acceptance by the relevant Applicant of a Modified Acceptance, in either case by signing the Capacity Agreement attached to such Access Request or Modified Acceptance and sending it as set forth herein to the relevant Applicant or the Operating Company, as the case may be, and **"Accept"**, **"Accepting"** and **"Accepted"** shall be construed accordingly. [*"Accettazione"* in the Italian text]

"Access Conditions" has the meaning given in clause 2.4.5 of chapter II. [*"Requisiti per l'Accesso"* in the Italian text]

"Access Request" means a written proposal to enter into a Non-Foundation Capacity Agreement or Spot Capacity Agreement (as the case may be), which proposal is: (a) submitted by an Applicant to the Operating Company pursuant to the relevant provisions of chapter II; (b) irrevocable pursuant to article 1329 of the Italian civil code for the period determined in accordance with clauses 2.4.2 (a)(ii), 2.4.2 (b)(i), or 2.4.3 (a) of chapter II (as the case may be); and (c) substantially in the form provided at Annex (a). [*"Richiesta di Accesso"* in the Italian text]

"Additional Charges" means any amount, other than the Regasification Service Charge and the Redelivery Service Costs, due by the Users to the Operating Company pursuant to this Regasification Code, including amounts due under letter (b) of clause 3.8.2 of chapter IV, and bank guarantee costs. [*"Corrispettivi Accessori"* in the Italian text]

"Adjusted Monthly Redelivery Programme" has the meaning given in Part 1 of Annex (k) (*"Gas Redelivery Procedure"*). [*"Programma di Riconsegna Mensile Modificato"* in the Italian text]

"Adjusted Monthly Redelivery Programme following requests for additional services" has the meaning assigned to it in the Part I of the Annex (k) (*"Gas Redelivery Procedure"*). [*"Programma di Riconsegna Mensile Modificato a seguito di richieste di ulteriori servizi"* in the Italian text]

"Adjusted Spot Redelivery Programme" has the meaning given in Part 2 of Annex (k) (*"Gas Redelivery Procedure"*). [*"Programma di Riconsegna Spot Modificato"* in the Italian text]

"Adjusted Spot Redelivery Programme following requests for additional services" has the meaning assigned to it in the Part 2 of the Annex (k) (*"Gas Redelivery Procedure"*). [*"Programma di Riconsegna Spot Modificato a seguito di richieste di ulteriori servizi"* in the Italian text]

Courtesy translation, not binding.

"AEEG Resolution" means any resolution of the Regulatory Authority for Electricity and Gas. ["Delibera AEEG" in the Italian text]

"Affected Party" has the meaning given in clause 7.3.1 of chapter III. ["Parte Colpita" in the Italian text]

"Affiliate" means, at any time and in relation to a Party, any Parent Company and any of the Subsidiaries of such Parent Company. ["Società del Gruppo" in the Italian text]

"Annexes" means the annexes to the Regasification Code listed in clause 2 of chapter I, paragraphs (a) to (k) inclusive. ["Allegati" in the Italian text]

"Annual Reconciliation for Inventory Loss and/or Gain": has the meaning given in clause 6.3 of Chapter III

"Annual Schedule Preferences" has the meaning given in clause 3.2.2 of chapter II. ["Preferenze per la Programmazione Annuale" in the Italian text]

"Annual Subscription Process" has the meaning given in clause 2.4.2 (a) of chapter II. ["Procedura Annuale di Sottoscrizione" in the Italian text]

"Annual Unloading Schedule" means the yearly schedule for Unloading Slots assigned by the Operating Company to each User pursuant to clause 3.2.3 of chapter II. ["Programma Annuale" in the Italian text]

"Applicant" means any person who submits an Access Request to the Operating Company. ["Richiedente" in the Italian text]

"Approved Insurance Company" means an insurance company (including captive insurance companies) that has an international reputation and whose long term unsecured and unguaranteed debt is rated BBB or higher by S&P or Baa2 or higher by Moody's. ["Compagnia Assicuratrice Approvata" in the Italian text]

"Approved Issuing Institution" means a bank or other institution whose long term unsecured and unguaranteed debt has a rating which matches or is higher than at least two of the following ratings given by the following rating agencies:

- (a) BBB+ by S&P;
- (b) Baa1 by Moody's; and/or
- (c) BBB+ by Fitch Ratings. ["Garante Approvato" in the Italian text]

"Available Capacity" means the aggregate of (i) the Unsubscribed Non-Foundation Capacity that is available for subscription (including Unsubscribed Foundation Capacity that is reclassified pursuant to clause 2.4.2 (a)(i) of chapter II), and (ii) any Released Non-Foundation Capacity (including Released Foundation Capacity that is reclassified pursuant to clause 2.4.2 (a)(i) of chapter II). ["Capacità Disponibile" in the Italian text]

Courtesy translation, not binding.

"Boil-off" means evaporation of LNG

"Business Day" means a Day on which commercial banks are generally open to the public for business in Milan. ["Giorno Lavorativo" in the Italian text]

"Capacity Agreement" means any agreement which is entered into, in accordance with the relevant provisions of chapter II, between the Operating Company and a User for the provision of the Service and shall comprise Foundation Capacity Agreement(s), Non-Foundation Capacity Agreement(s), and Spot Capacity Agreement(s). ["Contratto per la Capacità" in the Italian text]

"Capacity Charge" means the amounts payable by a User to the Operating Company as determined pursuant to clauses 8.1.1 (a) and 8.9.1 of chapter III. ["Corrispettivo di Capacità" in the Italian text]

"Capacity Make-Up" has the meaning given in clause 8.10 of chapter III. ["Capacità di Make-up" in the Italian text]

"Capacity Make-Up Balance" means, with respect to a User, the amount of Euro that such User can apply to Capacity Make-Up under a Capacity Agreement pursuant to clause 8.10.2 of chapter III, which amount shall be a continuing balance and shall be (i) equal to zero (0) as of the date on which such Capacity Agreement is entered into; and (ii) updated from time to time pursuant to clauses 8.1.2 (c), 8.9.2 and 8.10.2 of chapter III. ["Saldo della Capacità di Make-up" in the Italian text]

"Cargo Handling Manual" means the document relating to: (a) the interfacing of an LNG Tanker's operational procedures and the Terminal's docking procedures; (b) the connections between an LNG Tanker and the Terminal; (c) equipment inerting and cooling; (d) Unloading procedures; and (e) equipment drainage and disconnection of an LNG Tanker from the Terminal. ["Cargo Handling Manual" in the Italian text]

"Cavarzere Entry Point" means the Gas pipeline flange located in Cavarzere connecting the Terminal to the pipeline owned by the Transportation Company. ["Punto di Ingresso in Cavarzere" in the Italian text]

"CMr " means the metering unit charge which shall be determined in accordance with applicable Regulations.

"Competent Authority" means any Italian or European Union legislative, judicial, administrative or executive body, including the European Commission, the Italian Antitrust Authority (*Autorità garante della concorrenza e del mercato*), the Regulatory Authority for Electricity and Gas, the MSE and the Maritime Authorities. ["Autorità Competente" in the Italian text]

"Completion of Unloading" means, following the Unloading of an LNG Tanker, the situation where all LNG discharge and return lines have been disconnected and such LNG Tanker has been cleared by the Operating Company for departure. ["Completamento della Discarica" in the Italian text]

Courtesy translation, not binding.

"Consultation Committee" means the committee set up by the Operating Company in accordance with article 5 AEEG Resolution no. ARG/Gas. 55/09 of 7 May 2009. ["Comitato di Consultazione" in the Italian text]

"Continuous User" means any User other than a Spot User. ["Utilizzatore Continuativo" in the Italian text]

"Correction Factor for the Uncertainty inventory's Loss and/or Gain" or "FCI" has the meaning given in clause 6.3 of Chapter III.

"Cqs" means the commitment unit charge which shall be determined in accordance with applicable Regulations.

"Damaging Event" has the meaning given in clause 14.3 (a) of chapter III. ["Evento Dannoso" in the Italian text]

"Damaging User" has the meaning given in clause 14.3 (a) of chapter III. ["Utilizzatore Danneggiante" in the Italian text]

"Day" means a period of twenty-four (24) consecutive hours starting from 06:00 hours. ["Giorno" in the Italian text]

"Decree" means the legislative decree no. 164 of 23 May 2000 on "Implementation of EC directive no. 98/30 concerning common rules for the internal market in Gas, pursuant to article no. 41 of law 144 of 17 May 1999". ["Decreto Legislativo" in the Italian text]

"Delivery Point" means the Terminal flange located at the connection point between the Terminal's unloading arms and the stub pipes of an LNG Tanker's charge/discharge manifold on board an LNG Tanker. ["Punto di Consegna" in the Italian text]

"Demurrage" has the meaning given in clause 3.8.2 (a) of chapter IV. ["Controstallie" in the Italian text]

"Disclosing Party" has the meaning given in clause 18.3 of chapter III. ["Parte Divulgante" in the Italian text]

"Edison Gas" means Edison Gas S.p.A., a company formerly registered with the Milan *Registro delle Imprese* under no. 10578610144, VAT and tax code no. 10578610155. ["Edison Gas" in the Italian text]

"Electronic Communication System" means, together, those pages on the web-site of the Operating Company which are published for the purposes of providing the information referred to in, inter alia, clauses 2 and 3 of chapter II. ["Sistema di Comunicazione Elettronico" in the Italian text]

"Emergency Response Procedures" has the meaning given in clause 1 of chapter V. ["Piano di Emergenza" in the Italian text]

"Environment" means the air (including air within natural or man-made structures above

Courtesy translation, not binding.

or below ground or water), water (including the sea and ground and surface water) and/or land. [“Ambiente” in the Italian text]

"ETA" means the estimated time and date of arrival of an LNG Tanker at the Pilot Boarding Station, which is determined pursuant to clause 2 of chapter IV. [“ETA” in the Italian text]

"EURIBOR" means:

- (a) the Euribor rate at 1 month and 365 days as noted by the newspaper “Il Sole 24 ore”
- (b) if no rate is available pursuant to paragraph (a) above, such other alternative basis which will be determined by the Operating Company (acting in good faith) and notified to all Users, and which will be binding on all Parties. [“EURIBOR” in the Italian text]

"Euro" means the single currency of those member states of the European Union that have adopted or adopt such currency as their lawful currency in accordance with the legislation of the European Community relating to Economic and Monetary Union. [“Euro” in the Italian text]

"Excess Boil-off" means the quantity of LNG as determined according to the procedures set forth in clause 3.9 of chapter IV. [“Boil-off in Eccesso” in the Italian text]

"Final Redelivery Profile" has the meaning given in Part 1 of Annex (k) (“Gas Redelivery Procedure”). [“Profilo di Riconsegna Finale” in the Italian text]

"Final Terminal Capacity" means the capacity of the Terminal in any Thermal Year following the end of the Start-up Period, expressed as volumes of LNG that can be Unloaded and the maximum number of Unloadings during such Thermal Year, as determined by the Operating Company pursuant to clause 2.1.2 of chapter II. [“Capacità Definitiva del Terminale” in the Italian text]

"First Exchanging User" has the meaning given in clause 12.1.1 of chapter III. [“Primo Utilizzatore Scambiante” in the Italian text]

"First Demand Guarantee" means a first demand guarantee provided by a User, which is issued by an Italian branch of an Approved Issuing Institution pursuant to clause 10.1 (d) of chapter III, or pursuant to clause 10.2.1, 10.2.3 or 10.3.1 of chapter III, and which shall be substantially in the form provided at, and subject to the conditions set out in, Part II of Annex (b). [“Garanzia a Prima Richiesta” in the Italian text]

"First Demand Parent Company Guarantee" means a first demand guarantee provided by an Applicant or, as the case may be, by a User, which is issued by its Parent Company pursuant to clause 10.1(b), 10.2.1, 10.2.3 or 10.3.2 (b) of chapter III and which shall be substantially in the form provided at, and subject to the conditions set out in, Annex (c). [“Garanzia a Prima Richiesta della Società Controllante” in the Italian text]

Courtesy translation, not binding.

"First Thermal Year" means the period starting on the Start-up of Commercial Operations and ending at 06:00 hours on the immediately following 1st of October. ["Primo Anno Termico" in the Italian text]

"Fitch Ratings" means Fitch Ratings Ltd. (or its successor). ["Fitch Ratings" in the Italian text]

"Flexibility Service", means an additional service defined as per the Resolution 502/2013/R/Gas of the Authority for Electricity and Gas, for which the Operating Company makes available a Redelivery Program Variation on Day d for Day d+1

"Flexibility Service Charge" means the amounts due by a User to the Operating Company according to clause 8.1.1. of chapter III.

"Force Majeure" or **"Force Majeure Event"** has the meaning given in clause 7.1 of chapter III. ["Forza Maggiore" and "Evento di Forza Maggiore" in the Italian text]

"Foundation Capacity" means the portion of Terminal Capacity that the Operating Company has the right to allocate to one or more Users pursuant to MAP decree dated 26 November 2004, which was issued in accordance with Law no. 239 of 23 August 2004 on "Reform of the energy sector and delegation to the Government for the reorganisation of the applicable energy laws and regulations", and which was submitted by the MAP to the EU Commission on 3 December 2004 pursuant to article 22 of directive 2003/55/EC. ["Capacità Esentata" in the Italian text]

"Foundation Capacity Agreement" has the meaning given in clause 2.4.1 (a) of chapter II. ["Contratto per la Capacità Esentata" in the Italian text]

"Foundation Capacity User" has the meaning given in clause 2.4.1 (a) of chapter II. ["Utilizzatore della Capacità Esentata" in the Italian text]

"Gas" means any hydrocarbon or mixture of hydrocarbons consisting essentially of methane, other hydrocarbons and non-combustible gases in a gaseous state, which is extracted from the subsurface of the earth in its natural state, separately or together with liquid hydrocarbons. ["Gas" in the Italian text]

"Regulatory Authority for Electricity and Gas" means the Regulatory Authority for Electricity and Gas (*Autorità per l'Energia Elettrica e il Gas*) established by law no. 481 of 14 November 1995 with, *inter alia*, the responsibility of regulating and controlling the gas and electric power sectors. ["Autorità per l'Energia Elettrica ed il Gas" in the Italian text]

"Gas Quality Specifications" means the Gas quality specifications set out in Annex (h). ["Specifiche di Qualità del Gas" in the Italian text]

"Gas Redelivery Procedure" means the procedure for the Redelivery of Gas to Users, as described in clause 6.1.3 of chapter III, which is attached hereto as Annex (k). ["Procedura per la Riconsegna del Gas" in the Italian text]

"GME" means the Gestore dei Mercati Energetici S.p.A., the joint stock company assigned to, among others, economically managing the electricity market, as per article 5 of

Courtesy translation, not binding.

Legislative Decree 79/99, 2009 as well as the economic management of the gas market, as per article 30 of Law 99 dated July 23, 2009.

"GJ" means Giga Joule, which is equal to 1,000,000,000 Joule.

"Grid" means the national and regional transport system for Gas as defined in the MICA decree of the 22nd of December 2000, as such decree is published in the Gazzetta Ufficiale, serie generale, 23-11-2001 n. 18 but, for the purposes of this Regasification Code, excludes the pipeline which runs from the offshore plant of the Terminal to and including the Cavarzere Entry Point. ["Rete" in the Italian text]

"Grid Capacity Charge" means the amount payable by a User to the Operating Company pursuant to clause 8.1.1 (d) of chapter III. ["Corrispettivo di Rete in the Italian text"]

"Gross Heating Value" means the amount of heat liberated during the complete combustion of a specified quantity of gas in air, so that the pressure p_1 at which the reaction takes place remains constant and all combustion products are returned to the same specified temperature t_1 as that of the reactants, all of these products being in a gaseous phase except for the water which forms during combustion which condenses in a liquid state at temperature t_1 . When the amount of gas is specified on a volumetric base, the heating value is given by $H_v(t_1, V(t_2, p_2))$ where t_2 and p_2 are the gas volume (metering) reference conditions. The reference conditions are as follows: $t_1 = t_2 = 15^\circ\text{C}$; and $p_1 = p_2 = 1.01325$ bar which are the standard conditions for the volume given in Sm^3 . ["Potere Calorifico Superiore" in the Italian text]

"Interim Notice" means a notice sent by the Operating Company to an Applicant pursuant to clause 2.4.2 (a)(vii)(cc) or 2.4.2 (b)(iii)(cc) of chapter II (as the case may be) informing such Applicant that its Access Request will be Accepted or rejected (as the case may be) by the Operating Company only after the date specified in clauses 2.4.2 (a)(viii) and 2.4.2 (b)(iv) of chapter II respectively. ["Avviso Provvisorio" in the Italian text]

"Inventory's Loss and/or Gain" has the meaning given in clause 6.3 of Chapter III.

"Invoice Month" has the meaning given in clause 8.1.1 of chapter III. ["Mese di Fatturazione" in the Italian text]

"Joule" or its abbreviation **"J"** means the derived "SI unit of quantity of heat" as defined in ISO 1000 SI units and recommendations for the use of their multiples and of certain other units.

"Laytime" means a period of time determined pursuant to clause 3.8.1 of chapter IV, which shall commence in accordance with clauses 3.2 through 3.4 of chapter IV. ["Tempo di Stallia" in the Italian text]

"Liable User" has the meaning given in clause 3.8.2 (b) of chapter IV. ["Utilizzatore Responsabile" in the Italian text]

"LNG" (acronym for *liquefied natural gas*) means Gas which has been converted to a liquid state, at or below its boiling point and at a pressure of approximately 1 atmosphere.

Courtesy translation, not binding.

[“GNL” in the Italian text]

"LNG Quality Specifications" means the LNG quality specifications set out in Annex (i). [“Specifiche di Qualità del GNL” in the Italian text]

"LNG Tanker" means a vessel used for the transportation of LNG from a loading port to the Terminal. [“Nave Metaniera” in the Italian text]

"LNG Tanker Vetting Procedure" means the procedure issued by the Operating Company to vet the LNG Tankers, shipowners, and master/crew. [“Procedura di Verifica della Nave Metaniera” in the Italian text]

"Losses and Consumption" has the meaning given in clause 6.2 (a) of chapter III. [“Consumi e Perdite” in the Italian text]

"MAP" means the former Ministry of Productive Activities, now MSE.

"Maritime Authorities" means the Ministry of Infrastructures and Transport (*Ministero delle infrastrutture e dei trasporti*) and the port authority (*Capitaneria di porto*) of Chioggia. [“Autorità Marittime” in the Italian text]

"Maritime Charges" means (i) charges established by any authority with jurisdiction over the Terminal payable by the owner or charterer of an LNG Tanker including charges related to immigration and customs clearance for the LNG Tanker and its crew and harbour master dues and (ii) other expenditures normally attributable to an LNG Tanker arising from the delivery of LNG at the Terminal and include expenditures relating to pilotage, towage, escort or watch vessels, line handling and light dues. [“Oneri Marittimi” in the Italian text]

"Maritime Regulations" means the regulations, administrative provisions, acts and/or other provisions issued by the Maritime Authorities for the co-ordination of movement of LNG Tankers. [“Regolamenti Marittimi” in the Italian text]

“Maximum Daily send-out”: is the maximum volume flow, expressed in Sm³/day, as published on the Operating Company’s Electronic Communication System (www.adriaticlng.it)

"MICA" means the Ministry of Industry, Trade and Crafts. [“MICA” in the Italian text]

"MJ" means Mega Joule, which is equal to 1,000,000 Joule.

"Modified Acceptance" means a written counter-proposal pursuant to sub-section V of article 1326 of the Italian civil code to enter into a Non-Foundation Capacity Agreement (a) for a different portion of Terminal Capacity, (b) for a different number of Unloading Slots, (c) from an alternative start date, (d) for an alternative duration, and/or (e) subject to different conditions, than that specified in the relevant Access Request, which counter-proposal is: (a) submitted to the relevant Applicant by the Operating Company pursuant to the relevant provisions of chapter II; (b) irrevocable pursuant to article 1329 of the Italian civil code for the period determined in accordance with clauses 2.4.2 (a)(vii)(bb) or 2.4.2 (b)(iii)(bb) of chapter II (as the case may be); and (c) substantially in the form provided at

Annex (a). [“Accettazione Modificata” in the Italian text]

"Month" means a period beginning at 06:00 hours on the first Day of a calendar month and ending at 06:00 hours on the first Day of the following calendar month, and **"Monthly"** shall be construed accordingly. [“Mese” and “Mensile” in the Italian text]

"Monthly Adjustment" has the meaning given in clause 8.1.1 (a)(iii) of chapter III. [“Adeguamento Mensile” in the Italian text]

"Monthly Invoiced Quantity" has the meaning given in clause 8.1.1 (a) of chapter III. [“Quantità Mensile Fatturata” in the Italian text]

"Monthly Make-Up Euro" has the meaning given in clause 8.1.2 (c) of chapter III. [“Ammontare Mensile di Make-up” in the Italian text]

"Monthly Make-Up Quantity" has the meaning given in clause 8.1.2 (a) of chapter III. [“Quantità Mensile di Make-up” in the Italian text]

"Monthly Redelivery Programme" means the programme detailing the provisional quantity of Gas planned for Redelivery to each User during a Month pursuant to the Gas Redelivery Procedure and has the meaning assigned to it in the Part I of the Annex (k) (“Gas Redelivery Procedure”). [“Programma di Riconsegna Mensile” in the Italian text]

"Monthly Subscription Process" has the meaning given in clause 2.4.2 (b) of chapter II. [“Procedura Mensile di Sottoscrizione” in the Italian text]

"Moody's" means Moody's Investors Service Inc. (or its successor). [“Moody's” in the Italian text]

"MSE" means the Ministry for Economic Development, formerly the MAP.

"Net Present Value" has the meaning given in Annex (g). [“Valore Attuale Netto” in the Italian text]

"Net Unloaded LNG" means, following Completion of Unloading, the quantity of LNG that has been Unloaded from an LNG Tanker less any quantity of LNG corresponding to the quantity of Gas that has been transferred back to such LNG Tanker from the Terminal via the vapour return line in order to facilitate the Unloading. [“GNL Scaricato Netto” in the Italian text]

"Net Adjusted Unloaded LNG" means the net unloaded LNG adjusted to account for the uncertainty of measurements as defined in clause 5.1.3 (g) of Chapter III.

"Non-Foundation Capacity" means Terminal Capacity less Foundation Capacity. [“Capacità Regolata” in the Italian text]

"Non-Foundation Capacity Agreement" means a Capacity Agreement entered into by the Operating Company and a User pursuant to clause 2.4.2 of chapter II in respect of Non-Foundation Capacity. [“Contratto per la Capacità Regolata” in the Italian text]

Courtesy translation, not binding.

"Non-Foundation Capacity User" means a User that has entered into a Non-Foundation Capacity Agreement. ["Utilizzatore della Capacità Regolata" in the Italian text]

"Notice of Readiness" has the meaning given in clause 2.5 of chapter IV. ["Avviso di Prontezza" in the Italian text]

"Off-Spec Gas" means Gas which does not comply with the Gas Quality Specifications. ["Gas Fuori Specifica" in the Italian text]

"Off-Spec LNG" means LNG which does not comply with the LNG Quality Specifications. ["GNL Fuori Specifica" in the Italian text]

"OCIMF" means the Oil Companies International Marine Forum. ["OCIMF" in the Italian text]

"Operating Company" has the meaning given in the first recital. ["Gestore" in the Italian text]

"Parent Company" means a company that directly or indirectly controls another company pursuant to and for all legal purposes of article 2359, sub-section I, number (1) of the Italian civil code. ["Società Controllante" in the Italian text]

"Party" or **"Parties"** means the Operating Company and/or the relevant User, as applicable. ["Parte" or "Parti" in the Italian text]

"Parties' Data" has the meaning given in clause 18.6 of chapter III. ["Dati delle Parti" in the Italian text]

"Pilot Boarding Station" means the area near the Terminal the co-ordinates of which have been established by the Operating Company in accordance with instructions given by the Maritime Authorities. ["Punto di Imbarco Pilota" in the Italian text]

"Provisional Terminal Capacity" means the capacity of the Terminal in any Thermal Year during the Start-up Period, expressed as volumes of LNG that can be Unloaded and the maximum number of Unloadings during such Thermal Year, as determined by the Operating Company pursuant to clause 2.1.1 of chapter II. ["Capacità Provvisoria del Terminale" in the Italian text]

"Quantity Scheduled or Released" has the meaning given in clause 8.1.1 (a)(ii) of chapter III. ["Quantità Programmata o Rilasciata" in the Italian text]

"Quantity Unloaded" has the meaning given in clause 8.1.1 (a)(i) of chapter III. ["Quantità Scaricata" in the Italian text]

"Quotation Date" means, in relation to any six (6) month period for the purpose of establishing EURIBOR quotations, the day which is two (2) Business Days prior to the first day of such period. ["Data di Quotazione" in the Italian text]

"Reasonable and Prudent Operator" means a person who applies standards, practices and procedures generally followed and approved by persons participating in the LNG

and/or Gas industry in Europe with respect to the general conduct of such person's undertaking and such degree of skill, diligence, prudence and foresight as would reasonably and ordinarily be exercised by a skilled and experienced person engaged in undertakings of a similar nature to those contemplated by the Regasification Code, who takes into account the interests of the other party and complies with all Regulations and any other laws, regulations, administrative and judicial provisions and such like applicable to such person. ["Operatore Ragionevole e Prudente" in the Italian text]

"Reclaim Declaration" means a declaration to reclaim Released Capacity submitted to the Operating Company by a User pursuant to clause 2.6 (c) of chapter II which shall be in the form provided in Annex (f). ["Dichiarazione di Recupero" in the Italian text]

"Reconciliation Statement" has the meaning given in clause 8.9.1 of chapter III. ["Rendiconto di Riconciliazione" in the Italian text]

"Redelivery Point" means the Cavarzere Entry Point where the Operating Company makes the Gas, object of the Regasification Service of which the Users are the holders, available to the Transportation Company, which takes it over for the return to the same Users as part of the transportation service pursuant to Art.10bis of AEEG Resolution no. 167/05 as amended by the AEEG Resolution 297/2012/R/Gas . ["Punto di Riconsegna" in the Italian text]

"Redelivery Program Variation" means the additional increase or decrease change in the Redelivery of Gas during the Month as per the Monthly Redelivery Program/Adjusted Monthly Redelivery Program, Spot Redelivery Program/Adjusted Spot Redelivery Program, for all intents and purposes of article II.3.8.1 and as better described in Annex (o).

"Redelivery Service" means the performance by the Operating Company of (i) the obligations it has assumed under the Transportation Contract and (ii) the other obligations envisaged by the Regasification Code, in order to make the Gas available to the User at the Redelivery Point, and **"Redeliver"**, **"Redelivery"** and **"Redelivered"** shall be construed accordingly. ["Servizio di Riconsegna", "Riconsegnare", "Riconsegna" and "Riconsegnato" in the Italian text]

"Redelivery Service Costs" means, with respect to a User, the sum of the Grid Capacity Charge and the Variable Transportation Charge. ["Costi del Servizio di Riconsegna" in the Italian text]

"Regasification" means the activities of (a) extraction of LNG from the storage tanks, (b) its pressurisation (c) its conversion from a liquid to a gaseous state, and (d) making it available for injection into the Grid at the Cavarzere Entry Point and **"Regasify"** and **"Regasified"** shall be construed accordingly. ["Rigassificazione" in the Italian text]

"Regasification Code" means this document (including the Annexes hereto) adopted by the Operating Company pursuant to article 24, sub-section 5 of the Decree. ["Codice di Rigassificazione" in the Italian text]

"Regasification Service" means, the receipt of LNG Tankers, Unloading, Storage, Regasification of LNG and Redelivery at the point where the Terminal is connected to the

Courtesy translation, not binding.

transmission system of the energy equivalent of gas of the LNG delivered, less Losses and Consumption. [“Servizio di Rigassificazione” in the Italian text]

"Regasification Service Charge" means, with respect to a User, the Capacity Charge [“Tariffa per il Servizio di Rigassificazione” in the Italian text]

"Regulations" means all laws, regulations, administrative and judicial provisions, acts, and/or other provisions issued by any Competent Authority, including the Decree and the Maritime Regulations. [“Normativa Applicabile” in the Italian text]

"Released Capacity" means, in respect of any User, the Released Foundation Capacity and/or the Released Non-Foundation Capacity of such User. [“Capacità Rilasciata” in the Italian text]

"Release Declaration" means a declaration of release of Subscribed Capacity submitted to the Operating Company by a User pursuant to clause 2.6 (a) of chapter II which shall be in the form provided in Annex (e). [“Dichiarazione di Rilascio” in the Italian text]

"Released Foundation Capacity" means any Subscribed Foundation Capacity which any User has released pursuant to clause 2.6 (a) of chapter II, or which is deemed to have been released pursuant to clause 3.2.2 of chapter II, less any such capacity that is reclassified as Released Non-Foundation Capacity pursuant to clause 2.4.2 (a) of chapter II. Such capacity shall cease to be Released Foundation Capacity on the date when and to the extent that (a) the Operating Company enters into one or more new Capacity Agreement(s) for such Released Capacity, or (b) a User has reclaimed such Released Foundation Capacity pursuant to clause 2.6 (c) of chapter II. [“Capacità Esentata Rilasciata” in the Italian text]

"Released Non-Foundation Capacity" means any Subscribed Non-Foundation Capacity which any User has released pursuant to clause 2.6 (a) of chapter II, or which is deemed to have been released pursuant to clause 3.2.2 of chapter II, plus any Released Foundation Capacity that is reclassified as Released Non-Foundation Capacity pursuant to clause 2.4.2 (a)(i) of chapter II. Such capacity shall cease to be Released Non-Foundation Capacity on the date when and to the extent that (a) the Operating Company enters into one or more new Capacity Agreement(s) for such Released Non-Foundation Capacity, or (b) a User has reclaimed such Released Capacity pursuant to clause 2.6 (c) of chapter II. [“Capacità Regolata Rilasciata” in the Italian text]

"Representations" has the meaning given in clause 2.4.1 of chapter III. [“Dichiarazioni” in the Italian text]

"S&P" means Standard & Poor's Rating Services, a division of the McGraw Hill Companies, Inc. (or its successor). [“S&P” in the Italian text]

"Second Exchanging User" has the meaning given in clause 12.1.1 of chapter III. [“Secondo Utilizzatore Scambiante” in the Italian text]

"Scheduled Arrival Range" means (a) the first forty-eight (48) hours of an Unloading Slot for LNG Tankers that load LNG at a port located outside the Mediterranean Sea or (b) the first twenty-four (24) hours of an Unloading Slot for LNG Tankers that load LNG

Courtesy translation, not binding.

at a port located within the Mediterranean Sea, during which an LNG Tanker is scheduled to tender its Notice of Readiness or (c) for Spot Capacity, the period of time specified by the Operating Company pursuant to clause 2.3 (e) of chapter II. [“Cancello di Accettazione” in the Italian text]

"Service" means collectively (i) the Regasification Service and (ii) the Redelivery Service. [“Servizio” in the Italian text]

"Service Conditions" has the meaning given in clause 2.3.1 of chapter III. [“Requisiti per il Servizio” in the Italian text]

"Temporary Storage Service", means an additional service defined as per the Resolution 502/2013/R/Gas of the Authority for Electricity and Gas, for which the Operating Company makes available to its Users a service of temporary storage of LNG and subsequent Redelivery of Gas.

"Shipowner" means any person (including any Applicant or User) who operates and/or is deemed to operate and/or owns an LNG Tanker pursuant to article 265 and/or article 272 and subsequent articles of the Italian navigation code or pursuant to any other applicable law. [“Armatore” in the Italian text]

"SIGTTO" means the Society of International Gas Tanker and Terminal Operators. [“SIGTTO” in the Italian text]

"Sm³" means the quantity of Gas, free of water vapour, occupying the volume of one (1) Cubic Metre at the temperature of 15°C and absolute pressure of 1.01325 Bar. [“Sm³” in the Italian text]

"Specific Density" means the ratio between the mass of a volume of Gas and the mass of a corresponding volume of dry air at the same temperature (15°C) and pressure (1.01325 Bar) conditions. [“Densità Relativa” in the Italian text]

"Spot Capacity" means for any given Month “M”: (a) Available Capacity that has not been allocated during the course of the Monthly Subscription Process conducted during the course of the preceding Month (i.e., Month M-1); and (b) Terminal Capacity that otherwise becomes available during such Month “M” due to unexpected and/or unforeseen circumstances such as delays or failures to Unload, expressed as a quantity of LNG that can be Unloaded during such given period, as determined by the Operating Company pursuant to clause 2.2 of chapter II. [“Capacità Spot” in the Italian text]

"Spot Capacity Agreement" means a Capacity Agreement entered into by the Operating Company and a User pursuant to clause 2.4.3 of chapter II in respect of Spot Capacity. [“Contratto per la Capacità Spot” in the Italian text]

"Spot Redelivery Period" means the specific period of time, as stipulated in the applicable Spot Capacity Agreement, during which the Operating Company is scheduled to complete the Redelivery Service with respect to the LNG volume delivered during a Spot User's Unloading Slot. [“Periodo di Riconsegna per l'Utilizzatore della Capacità Spot” in the Italian text]

"Spot Redelivery Programme" has the meaning given in Part 2 of Annex (k) ("Gas Redelivery Procedure"). ["Programma di Riconsegna Spot" in the Italian text]

"Spot User" means a User that has entered into a Spot Capacity Agreement. ["Utilizzatore della Capacità Spot" in the Italian text]

"Spot Cargo" means any cargo of LNG which is delivered, or is scheduled to be delivered, to the Terminal pursuant to a Spot Capacity Agreement. ["Carico Spot" in the Italian text]

"Spot Subscription Process" has the meaning given in clause 2.4.3 of chapter II. ["Procedura di Sottoscrizione Spot" in the Italian text]

"Spot Unloading Schedule" means a schedule for Unloading a Spot Cargo which is set pursuant to clause 3.4 of chapter II. ["Programma Spot" in the Italian text]

"Start-up of Commercial Operations" means the date on which the first Unloading of LNG at the Terminal occurs pursuant to a Capacity Agreement that is 2nd (second) November 2009 (two thousand and nine). ["Inizio delle Operazioni Commerciali" in the Italian text]

"Start-up Period" means the period from (a) the Start-up of Commercial Operations until (b) a date determined by the Operating Company, it being estimated that such date will fall approximately three (3) years after the Start-up of Commercial Operations. ["Periodo di Avviamento" in the Italian text]

"Storage" means the storage of LNG in storage tanks at the Terminal, as more fully described in clause 1.1 (b) of chapter II. ["Stoccaggio" in the Italian text]

"Subsidiary" means any company directly or indirectly controlled by, or under the joint control of, another company pursuant to article 2359, sub-section I, numbers (1) and (2) of the Italian civil code. ["Società Controllata" in the Italian text]

"Subscribed Capacity" means, in respect of any User, the Subscribed Foundation Capacity, Subscribed Non-Foundation Capacity or Subscribed Spot Capacity, as the case may be, subscribed by such User pursuant to the relevant Capacity Agreement. ["Capacità Sottoscritta" in the Italian text]

"Subscribed Foundation Capacity" means the portion of Foundation Capacity that is the object of Foundation Capacity Agreement(s). ["Capacità Esentata Sottoscritta" in the Italian text]

"Subscribed Non-Foundation Capacity" means the portion of the Non-Foundation Capacity that is the object of Non-Foundation Capacity Agreement(s). ["Capacità Regolata Sottoscritta" in the Italian text]

"Subscribed Spot Capacity" means the portion of the Spot Capacity that is the object of Spot Capacity Agreement(s). ["Capacità Spot Sottoscritta" in the Italian text]

"Subscription Allocation Criteria" means the ranking priority for Access Requests as set forth in clause 2.4.2 (a)(iii), (iv), (v), and (vi) of chapter II. ["Criteri per il

Courtesy translation, not binding.

Conferimento” in the Italian text]

"Subscription Month" means the Month during which a Monthly Subscription Process is taking place. [“Mese di Sottoscrizione” in the Italian text]

"System" means the data processing platform for the Redelivery of Gas injected into the Grid at the Redelivery Point, according to the Snam Rete Gas network code.

"Technical Disputes" means:

- (a) any dispute on technical issues, including any dispute arising out of or in connection with the following:
 - (i) the equipment, performance, operation, maintenance and/or safety of the Terminal;
 - (ii) the interpretation and/or application of any of the Annexes (h) through (k); and/or
 - (iii) the quantity, quality, measurement, allocation, attribution and/or balancing of any LNG and/or Gas;
- (b) any dispute on whether a particular dispute relates to a technical issue. [“Controversie Tecniche” in the Italian text]

“Temporary Storage Service Charge” significa gli importi dovuti da un Utente al Gestore ai sensi dell’articolo 8.1.1. del Capitolo III.

"Terminal" means the offshore regasification plant located at an approximate water depth of 30 metres in the Adriatic Sea in Italian territorial waters at approximately lat. 45°05' N, long. 12°35' E approximately 17 km offshore Porto Levante (Rovigo), comprising a gravity-based structure for the docking of LNG Tankers and certain other facilities, all as better described in clause 1 chapter II. The plant location is provided in annex (I) [“Terminale” in the Italian text]

"Terminal Capacity" means the Provisional Terminal Capacity or the Final Terminal Capacity, as the case may be. [“Capacità del Terminale” in the Italian text]

"Terminal Insurance Policy" has the meaning given in clause 11.1 of chapter III. [“Polizza Assicurativa del Terminale” in the Italian text]

"Terminal Regulations" means the rules and procedures set forth by the Operating Company for all operations at the Terminal from an LNG Tanker docking to undocking, such rules being in compliance with the Maritime Regulations and all other relevant Regulations. [“Regolamenti del Terminale” in the Italian text]

"Thermal Year" means that period commencing at 06:00 hours on the 1st of October and ending on the immediately succeeding 1st of October at 06:00 hours. [“Anno Termico” in the Italian text]

Courtesy translation, not binding.

"Three (3) Month Schedule" means the three (3) Month schedule of the relevant Unloading Slots that the Operating Company provides to each User pursuant to clause 3.3.2 of chapter II. ["Programma Trimestrale" in the Italian text]

"Three (3) Month Schedule Preferences" has the meaning given in clause 3.3.1 of chapter II. ["Preferenze per la Programmazione Trimestrale" in the Italian text]

"TJ" means Tera Joule, which is equal to 1,000,000,000,000 Joule.

"Total Term" means the period starting on the commencement date specified in the relevant Capacity Agreement and ending on the expiry date specified in such Capacity Agreement. ["Durata Totale" in the Italian text]

"Transferee" has the meaning given in clause 12.1.1 of chapter III. ["Assegnatario" in the Italian text]

"Transferring User" has the meaning given in clause 12.1.1 of chapter III. ["Assegnante" in the Italian text]

"Transportation Contract" means any contract entered into by the Operating Company, on behalf of the Users, and the Transportation Company to secure access to the Grid for the Users, in accordance with the provisions of articles 3 and 6 of the AEEG Resolution no. 168 of 31 July 2006. ["Contratto di Trasporto" in the Italian text"]

"Transportation Company" means the person or persons which, from time to time and for the purpose of article 8 of the Decree, transports Gas directly after the Cavarzere Entry Point. ["Impresa di Trasporto" in the Italian text]

"Transport System User" means any transport service user indicated by the User to the Operating Company, for the full or partial division of their own Gas as per art. 10 bis.6 of AEEG Resolution 167/05 (as amended by AEEG Resolution 297/2012/R/Gas) and according to the rules defined in Annex (k).

"Unloading" means the technical operations (following the mooring of an LNG Tanker at the Terminal and the safe setting of the receiving equipment) used to transfer an LNG Tanker's cargo to the Terminal's storage tanks, in accordance with the procedures provided in the Cargo Handling Manual, and **"Unload"** and **"Unloaded"** and similar expressions shall be construed accordingly. ["Discarica", "Scaricare" and "Scaricato" in the Italian text]

"Unloading Slot" means the period of time during which an LNG Tanker is scheduled to arrive, Unload and leave the berth, which period shall in all cases commence at 12:00 hours and end (a) seventy-eight (78) consecutive hours later for LNG Tankers that load LNG at a port located outside the Mediterranean Sea or (b) fifty-four (54) consecutive hours later for LNG Tankers that load LNG at a port located within the Mediterranean Sea or (c) for Spot Capacity, at the time specified by the Operating Company pursuant to clause 2.3 (e) of chapter II. ["Slot di Discarica" in the Italian text]

"Unloading Slot Unavailability Period" has the meaning given in clause 3.7.1 of chapter II. ["Periodo di Indisponibilità degli Slot di Discarica" in the Italian text]

Courtesy translation, not binding.

"Unsubscribed Capacity" means the aggregate of any Available Capacity, Unsubscribed Foundation Capacity and Spot Capacity available for subscription. ["Capacità Non Sottoscritta" in the Italian text]

"Unsubscribed Foundation Capacity" means Foundation Capacity that is not subject to a Capacity Agreement. ["Capacità Esentata Non Sottoscritta" in the Italian text]

"Unsubscribed Non-Foundation Capacity" means Non-Foundation Capacity that is not subject to a Capacity Agreement. ["Capacità Regolata Non Sottoscritta" in the Italian text]

"USD" means United States Dollars, the lawful currency of the United States of America. ["Dollari Usa" in the Italian text]

"User" means any person to whom Terminal Capacity or Spot Capacity is allocated and to whom the Operating Company provides the Service pursuant to a Capacity Agreement entered into between such person and the Operating Company. ["Utilizzatore" in the Italian text]

"User Insurance Policy" has the meaning given in clause 11.2 of chapter III. ["Polizza Assicurativa dell'Utilizzatore" in the Italian text]

"Variable Transportation Charge" means the amount payable by a User to the Operating Company pursuant to clause 8.1.1 (g) of chapter III. ["Corrispettivo Variabile di Trasporto" in the Italian text"]

"Wobbe Index" means the Gross Heating Value on a volumetric basis at specified reference conditions divided by the square root of the Specific Density at the same specified metering reference conditions of Gas. ["Indice di Wobbe" in the Italian text]

"Year" means the time period beginning at 06:00 hours on the 1st of January of any calendar year and ending at 06:00 hours on the 1st of January of the immediately following calendar year. ["Anno" in the Italian text]

I.1.2 Interpretation

- 1.2.1 Except as otherwise specifically stated, reference to articles, clauses, chapters or Annexes shall be to articles, clauses and chapters of, Annexes to, this Regasification Code.
- 1.2.2 The heading of each article, clause or chapter of the Regasification Code has been written solely for reference purposes and should not be used in the interpretation of the Regasification Code and/or any Capacity Agreement.
- 1.2.3 Save where otherwise required from the context, terms used in the singular also refer to the plural and vice versa, and masculine pronouns may also refer to feminine subjects.
- 1.2.4 The terms "including" and "include" shall be construed to be without limitation.
- 1.2.5 All units of measurement used in this Regasification Code and not defined in clause 1.1 of chapter I will be determined in accordance with the "*Système Internationale d'unités*",

Courtesy translation, not binding.

published by *Bureau International des Poids et Mesures*.

- 1.2.6 A reference to a document, the Regasification Code or a Capacity Agreement includes a reference to that document, the Regasification Code or that Capacity Agreement as amended, supplemented, superseded, or renewed from time to time in accordance with its terms; and where reference is made to any Regulations or other laws, regulations, administrative or judicial provisions or such like, this will include all enactments, amendments, modifications of, or other laws, regulations, administrative or judicial provisions amending, modifying, or superseding, any of the same from time to time.
- 1.2.7 A reference to any person includes its successors, assignees and transferees and in the case of a User, its Transferees.
- 1.2.8 In the event of any discrepancy between the provisions contained in chapters I to IV of the Regasification Code and any Annex, the provisions in chapters I to IV of the Regasification Code shall prevail.
- 1.2.9 The Regasification Code has been drafted, and each Capacity Agreement shall be drafted and executed, in the Italian language, which shall be regarded as the sole authoritative and official language and shall be the sole language to be referred to in construing or interpreting the Regasification Code and any Capacity Agreement, notwithstanding any translation of the Regasification Code and any Capacity Agreement into any other language.
- 1.2.10 All references to time shall be to Italian time, unless expressly provided otherwise.

I.2 LIST OF ANNEXES

The following Annexes are integral to and shall form part of the Regasification Code:

- (a) Annex (a), which is composed of five (5) Parts, namely: Part I, being the form of Access Request for all Capacity Agreements other than for any Foundation Capacity Agreement; Part II, being the form of Access Request for Capacity Make-Up; Part III, being the form of Modified Acceptance for Non-Foundation Capacity Agreement; Part IV, being the Non-Foundation Capacity Agreement; and Part V, being the Spot Capacity Agreement;
- (b) Annex (b), which is composed of two (2) Parts, namely: Part I, being the form of undertaking to issue a First Demand Guarantee and Part II, being the form of First Demand Guarantee;
- (c) Annex (c), being the form of First Demand Parent Company Guarantee;
- (d) Annex (d), being the requirements for the Terminal Insurance Policy and User Insurance Policy;
- (e) Annex (e), being the form of Release Declaration;
- (f) Annex (f), being the form of Reclaim Declaration;

Courtesy translation, not binding.

- (g) Annex (g), being the definition of and method for calculation of the Net Present Value;
- (h) Annex (h), Gas Quantity, Quality and Pressure Specifications;
- (i) Annex (i), LNG Quantity, Quality and Pressure Specifications;
- (j) Annex (j), Testing and Measuring Methods; and
- (k) Annex (k), Gas Redelivery Procedure.
- (l) Annex (l), Location of the Terminal
- (m) Annex (m), Plan
- (n) Annex (n), Description of berthing facilities
- (o) Annex (o), Additional services: Flexibility Service and Temporary Storage Service

I.3 APPLICABLE LAW

The Regasification Code and each Capacity Agreement shall be governed by Italian law.

I.4 RESOLUTION OF DISPUTES

I.4.1 Competence of the Regulatory Authority for Electricity and Gas

According to article 35 of the Decree, disputes arising in relation to access to the natural gas system (as defined in the Decree) shall be settled by the Regulatory Authority for Electricity and Gas. The procedure to be followed in such cases shall be established by governmental regulation (to be issued in accordance with the provisions of art. 2, section 24, of Law no. 481 of 14 November 1995).

Until the above mentioned governmental regulation is adopted, any dispute arising out of or in connection with a Capacity Agreement and/or in connection with the Regasification Code shall be settled according to the procedures set forth under clauses 4.2 and 4.3 of this chapter I below.

I.4.2 Submission to jurisdiction

Any and all disputes arising out of or in connection with a Capacity Agreement between the Operating Company and the User which is a Party to such Capacity Agreement and/or in connection with the Regasification Code, other than Technical Disputes referred to in clause 4.3 of chapter I, shall be subject to the Italian jurisdiction and to the exclusive competence of the Courts of Milan. For the purpose of proceedings (including for the purpose of receiving service of process), each User elects domicile in Milan at the address set out in the relevant Capacity Agreement, as indicated in clause 16.1 (a)(ii) of chapter III.

I.4.3 Arbitration of Technical Disputes

Courtesy translation, not binding.

If a Party believes that a Technical Dispute has arisen, such Party shall notify the other Party in writing, specifying the events or circumstances that are the object of such Technical Dispute. The Technical Dispute shall be finally settled by an arbitrator, to be appointed by common agreement of the Parties involved in such Technical Dispute and, failing such agreement on or before the twentieth (20th) Business Day after receipt of the notification by the second mentioned Party, by the Rector of the University of Genoa upon request of the most diligent Party. Upon an arbitrator being agreed or selected as aforesaid, the Parties (or either Party) shall forthwith notify such arbitrator of his selection and shall request him within five (5) Business Days to confirm in writing whether or not he is willing and able to (and does in fact) accept the appointment. If the proposed arbitrator is either unwilling or unable to accept such appointment or shall not have confirmed his acceptance of such appointment within the said period of five (5) Business Days, then (unless the Parties are able to agree upon the appointment of another arbitrator) the matter shall again be referred by the Parties (or either Party) as aforesaid to the Rector of the University of Genoa who shall be requested to make a further selection and the process shall be repeated until an arbitrator is found who accepts appointment. The arbitrator shall have appropriate technical expertise and experience in the Gas sector and specifically with regard to the transportation, discharge, regasification, storage and sale of LNG. The arbitration proceedings shall be conducted and the arbitrator's determinations shall be rendered in the Italian language. The place of arbitration shall be Milan. The arbitrator shall act as an *arbitro irrituale* for the resolution of the Technical Dispute through ascertaining the technical issues involved in compliance with *principio del contraddittorio*, and shall render its determinations applying Italian law. Such determinations shall be rendered in such a manner so as to comply with and respect, to the maximum extent possible, the letter and the spirit of this Regasification Code, including each and all of its Annexes, rather than with a view to reaching a compromise or settlement between the different positions of the Parties. The arbitrator's determinations shall be in writing, specifying the reasons upon which they are based, and shall be rendered within one hundred and twenty (120) Business Days from the date of acceptance of the appointment unless such timing is extended by mutual agreement of the Parties in writing. The costs of any reference of a Technical Dispute to an arbitrator shall be borne between the Parties concerned in such proportions as may be determined by the arbitrator. The arbitrator's determinations rendered in accordance with this clause 4.3 shall be final and binding on the Parties involved in such Technical Dispute, and it shall have the effect of a final agreement between the Parties on the matter submitted to the arbitrator.

CHAPTER II

TERMINAL SPECIFICATIONS, ACCESS PROCEDURES AND SCHEDULING

II.1 DESCRIPTION OF THE PLANT AND SYSTEMS

II.1.1 Terminal specifications

The Terminal through which the Operating Company provides the Service shall have the following specifications:

- (a) the ability to receive, berth, and Unload LNG Tankers having the following specifications:

- (i) LNG Tanker specifications:

Minimum Capacity:	65,000 cubic metres
Dead-weight at arrival:	Maximum 84,000 metric tons
Displacement at arrival:	Maximum 120,000 metric tons
Overall length:	Maximum 300 metres
Beam:	Maximum 49.5 metres
Arrival draft:	Maximum 12.0 metres
Rate of discharge:	12,000 cubic metres per hour against an LNG head of 80 metres at the Delivery Point

- (ii) berthing facilities that comply with SIGTTO and OCIMF guidelines (as amended from time to time) at which the LNG Tankers can, when permitted by Maritime Regulations, safely reach, fully laden, and safely depart, and at which the LNG Tankers can lie safely berthed and discharge safely afloat, unless prevented from doing so by bad weather and/or sea conditions. The indication of the berthing facilities for LNG Tankers is given in Annex (n);
- (iii) Unloading facilities (including three (3) unloading arms) capable of receiving LNG at a rate that will permit the full discharge of a fully loaded LNG Tanker within twelve (12) hours of pumping time at a pumping rate of not less than twelve thousand cubic metres (12,000 m³) per hour;
- (iv) vapour return facilities (including one (1) vapour return arm) of sufficient capacity to transfer to an LNG Tanker quantities of regasified LNG, necessary for the safe Unloading of LNG at such rates, pressures and temperatures as may be required by the design of the LNG Tanker and good operating practice;
- (v) facilities for liquid or gaseous nitrogen adequate to purge the unloading arms;

Courtesy translation, not binding.

- (b) LNG storage tanks having an aggregate working capacity of at least two hundred fifty thousand cubic metres (250,000 m³);
- (c) LNG regasification facilities as follows;
 - i. LNG pressurization units: LNG is pumped from the storage tanks using in-tank pumps which feeds the high pressure (HP) send-out pumps. Boil-off gas from the storage tanks is compressed and recondensed in the boil-off gas handling system. The condensed liquid will also be fed to the HP send-out pumps. There are 4 (four) in-tank pumps, and 5 (five) HP send-out pumps are installed. Four of the HP pumps will be required under normal operating conditions, while the fifth HP pump will provide spare or capacity for peak send-out;
 - ii. LNG vaporization units: The LNG vaporization system vaporizes the discharged LNG from the high pressure send-out pumps and the resulting gas will flow to the natural gas send-out pipeline. The system includes 4 (four) Open Rack Vaporizers (ORVs) and one Waste Heat Recovery (WHR) LNG vaporizer. Three ORVs and one WHR LNG vaporizer are needed to operate in normal operating conditions. The fourth ORV is a spare during maintenance of one of the other vaporizers or to satisfy short-term peak requirements
 - iii. Boil-off gas (BOG) Handling: BOG from the storage tanks together with flash vapor and displaced vapor during a ship unloading operation will be collected in a vapor balance header. Most of the displaced vapor will be sent back to carrier tanks during unloading operation. All the gas from the LNG storage tanks, less the vapor sent back to the LNG Tanker during unloading, will be compressed by two BOG compressors and recondensed in the recondenser.
- (d) appropriate systems for: facsimile, telephone and radio communications with LNG Tankers and, emergency shut downs, in accordance with the SIGTTO recommendations and guidelines (as may from time to time be amended) for linked ship/shore emergency shut down;
- (e) required utility systems, including 3 (three) gas turbine electric power generators for the operation of the Terminal;
- (f) control and safety systems for the operation of the Terminal, control and safety systems of the Terminal are composed of two subsystems:
 - Distributed Control System (DCS) whose functions are collecting, processing and adjusting process parameters and the supervision of the Terminal;
 - Instrumental Security System (SIS), whose function is to implement a default auto safety in case of emergency;
- (g) a thirty inch (30") diameter gas pipeline comprised of an underwater section to the beach landfall and a subsequent onshore section that connects the offshore plant to the Cavarzere Entry Point;
- (h) a metering station for the Gas, immediately upstream of the Cavarzere Entry Point;

Courtesy translation, not binding.

- (i) the quantity of Gas and/or LNG required to make the Terminal operational; and
- (j) an Electronic Communication System built and implemented by the Operating Company in a manner designed to fulfil the requirements of this Regasification Code.

The Operating Company will not, as part of the Service, provide or procure the provision of tugs, pilots, escort or watch vessels, ballast, bunkering, mooring, line handling or payment of light dues that may be required by any User or LNG Tanker. The Operating Company may, if so requested by the Users, provide or procure the provision of maritime services as separate services to the Users and/or the LNG Tankers in order to allow the LNG Tankers to reach, lie at, and depart from the berthing facilities of the Terminal. The terms and conditions for the provision of such services and how to apply are posted on the Electronic Communication System and addressed separately on the basis of a standard contract, ensuring transparent and non-discriminatory and equal treatment for Users.

The Operating Company will provide and maintain the required quantity of Gas and/or LNG specified in clause 1.1 (j) of chapter II without any liability to Users.

II.2 CAPACITY

II.2.1 Calculation of the Terminal Capacity

The Terminal Capacity shall be determined by considering the technical and operational limits of the Terminal, as established by the Operating Company, taking into account the number and duration of Unloading Slots, Storage capacity, send-out capacity, and the available Gas pipeline capacity at the Cavarzere Entry Point.

The Terminal has a nominal capacity of 8 (eight) billion cubic meters of gas per year authorized by the Competent Authority. This capacity is the design capacity under normal operating conditions and without considering the operational constraints and the limitations imposed by infrastructure it is connected.

In order to achieve this nominal capacity the Operating Company has a peak capacity that, within the constraints of security and reliability, is the capacity that the Terminal can be reached by using all available equipment (including redundant equipment) within the constraints and operating restrictions imposed by the infrastructure it is connected.

To assess the Terminal Capacity the following values must be considered:

- a. unloading capacity: the unloading capacity within a reference period (e.g.: Thermal Year) of operations at the Terminal is defined taking into account :
 - i maximum number of Unloading Slots
 - ii amount of LNG unloaded by the LNG Tankers in each of the Unloading Slots, also taking into account the quality of the LNG
- b. send out capacity: the send out capacity depends, amongst other things on,
 - i the maintenance plan
 - ii the availability of back-up equipment

Courtesy translation, not binding.

- iii the availability of each equipment
- iv the Terminal Use and Loss Gas
- v any constraints imposed by the infrastructure that is connected to the Terminal or by the marine conditions
- vi the LNG quality, as, for example, the pressurization unit capacity depends on the density of the LNG unloaded.

Due to the special technical aspects of the Terminal and the variables that can be ascertained only during the Start-up Period, the Terminal Capacity will be determined in line with the following articles

2.1.1 Provisional Terminal Capacity

The Operating Company shall determine and publish the Provisional Terminal Capacity for the First Thermal Year and for the immediately subsequent Thermal Year as soon as it is reasonably able to do so.

By the 1st (first) of June, or the following Business Day if the 1st (first) of June is not a Business Day, of each subsequent Thermal Year during the Start-up Period, the Operating Company shall advise the Provisional Terminal Capacity for the subsequent Thermal Year, which shall be published on the Electronic Communication System no later than the Business Day after its determination.

It is acknowledged by the Operating Company and all Users that the Provisional Terminal Capacity may be lower than the Final Terminal Capacity. Foundation Capacity User(s) shall have first priority to utilize the portion of Provisional Terminal Capacity as provided in their Foundation Capacity Agreement(s).

2.1.2 Final Terminal Capacity

The Final Terminal Capacity must be determined by the Operating Company no later than the 1st of June in the final Thermal Year of the Start-up Period, or within the following Business Day if the 1st (first) of June is not a Business Day, and shall be published on the Electronic Communication System no later than the Business Day after its determination.

II.2.2 Spot Capacity

Once the Operating Company determines that there is Spot Capacity available, i.e. that the following conditions are met:

- (a) the Terminal berth is available to secure berthing of an LNG Tanker for a period of at least three (3) consecutive Days;
- (b) there is sufficient available capacity in the storage tanks of the Terminal to Unload the quantities of LNG which are the object of the Spot Capacity;
- (c) the Unloading of such Spot Capacity will not cause any interferences and/or delays or otherwise affect the Unloading of the other LNG Tankers that are scheduled for Unloading on the basis of the Three (3) Month Schedule of any relevant User, unless the relevant Parties agree to an amendment to such Three Month

Courtesy translation, not binding.

Schedule(s) pursuant to clause 3.6 of chapter II, nor will it affect the Redelivery of Gas to other Users that, according to article 6.1.4. letter (a) of chapter III, have communicated to the Operating Company their preference for the Redelivery profile which foresees the Redelivery to the Spot Users, if the Spot Capacity is allocated; and

- (d) there is sufficient conferrable transportation capacity downstream of the Terminal to inject the Gas resulting from the LNG which is the object of the Spot Capacity on behalf of the User,

it shall promptly publish such Spot Capacity on the Electronic Communication System.

II.2.3 Posting of Terminal Capacity

The Operating Company shall promptly publish to, and at all times maintain on, the Electronic Communication System, an accurate status of the Terminal Capacity. The information to be published pursuant to this clause 2.3 shall be on a monthly basis and shall include:

- (a) Provisional Terminal Capacity or Final Terminal Capacity, as the case may be;
- (b) Foundation Capacity, subdivided into Foundation Capacity that is available for subscription (comprised of Unsubscribed Foundation Capacity plus Released Foundation Capacity) and Foundation Capacity that is not available for subscription (comprised of Subscribed Foundation Capacity less Released Foundation Capacity);
- (c) Non-Foundation Capacity, subdivided into Available Capacity and Non-Foundation Capacity that is not available for subscription;
- (d) in respect of Foundation Capacity that is available for subscription and Available Capacity, the number of available Unloading Slots in each Month and, if known, the timing of such Unloading Slots;
- (e) Spot Capacity that is available for subscription, including the following information:
 - (i) the commencement date and duration of the relevant Unloading Slot;
 - (ii) the Scheduled Arrival Range;
 - (iii) the maximum volume of LNG which can be Unloaded during the relevant Unloading Slot;
 - (iv) the due date and time for submission of Access Requests for such Spot Capacity, which shall take into account the timing for the allocation of the necessary transportation capacity by the Transportation Company;
 - (v) the latest date by which any such Access Request shall be Accepted; and
 - (vi) the Spot Redelivery Period and an indicative and non-binding Spot Redelivery Profile; and

Courtesy translation, not binding.

- (f) Available Capacity and Spot Capacity for which there is an Access Request pending, specifying the Unloading Slots requested and, if known, the timing of such Unloading Slots.

Any information published pursuant to this clause 2.3 shall be updated by the Operating Company no later than the penultimate Business Day of each Month or at such other times as are required under applicable Regulations or are reasonable under the circumstances, taking into account the purposes for which such information is being published.

II.2.4 Subscription of the Terminal Capacity

The Unsubscribed Capacity will be made available for subscription in accordance with this clause 2.4.

2.4.1 Subscription of Unsubscribed Foundation Capacity and Released Foundation Capacity

- (a) Operating Company may allocate Unsubscribed Foundation Capacity and/or Released Foundation Capacity to one or more Users ("**Foundation Capacity User(s)**") by entering into agreement(s) ("**Foundation Capacity Agreement(s)**") with such User(s) with respect to such Foundation Capacity.
- (b) No later than one (1) Business Day after entering into a Foundation Capacity Agreement, the Operating Company shall update its Electronic Communication System accordingly.

2.4.2 Subscription of Available Capacity

Any person meeting the requirements of the Regasification Code may become an Applicant for Available Capacity by submitting an Access Request to the Operating Company in accordance with the Annual Subscription Process or the Monthly Subscription Process, as set forth herein.

- (a) Annual Subscription Process: Available Capacity for the immediately following and subsequent Thermal Years shall be awarded to Applicants through the following process ("**Annual Subscription Process**"):
 - (i) On the first (1st) of June of each Thermal Year, or the following Business Day if the 1st (first) of June is not a Business Day, the Operating Company shall reclassify all Unsubscribed Foundation Capacity and all Released Foundation Capacity for the immediately following Thermal Year as Unsubscribed Non-Foundation Capacity and Released Non-Foundation Capacity, respectively. On such date the Operating Company shall update the Electronic Communication System to show the accordingly revised Available Capacity.
 - (ii) All Applicants shall submit Access Requests for Available Capacity by no later than 17:00 hours on the first (1st) of July or within the same hour of the following Business Day if the 1st (first) of July is not a Business Day. Any such Access Request shall be irrevocable until 23:59 hours on the thirty first

(31st) of July.

- (iii) Available Capacity shall be allocated, on a priority basis, to Applicants filing Access Requests that meet the duration limits indicated for each category indicated under letters (aa), (bb), (cc), (dd) and (ee) below, in accordance with the following ranking priority:
 - (aa) Access Requests made by Applicants that are end clients or consortia of end clients, who import for self-consumption, except for electricity producers, for periods ranging between five (5) and ten (10) years;
 - (bb) Access Requests made by Applicants that undertake to offer the entire volume of Gas to be imported at the virtual exchange point, according to transparent and non-discriminatory conditions, for period ranging between five (5) and ten (10) years;
 - (cc) Access Requests made by Applicants that undertake to offer a quota of at least twenty percent (20%) of the volume of Gas to be imported at the virtual exchange point, according to transparent and non-discriminatory conditions, for periods of five (5) years;
 - (dd) Access Requests made by Applicants that import from States other than those from which long term importation agreements were in force as of 28 September 2004, for periods of five (5) years;
 - (ee) Access Requests made by Applicants which, at the time of the Access Request, hold a total allocated transportation capacity at entry points to the Grid, excluding storage interconnection points, below twenty-five percent (25%) of the overall transportation capacity allocated at the same entry points, for periods of five (5) years; and
 - (ff) any other Access Requests, for periods shorter than five (5) years.
- (iv) In the event that a portion of the Available Capacity is the object of two or more Access Requests of equal ranking within one of the categories mentioned under paragraphs (aa), (bb), (dd) and (ee) above, the Operating Company shall award such portion of the Available Capacity according to the following criteria:
 - (aa) largest aggregate volume of LNG over the term of the Non-Foundation Capacity Agreement;
 - (bb) earliest start date for the Service;
 - (cc) shortest overall duration of the Service; and
 - (dd) fewest number of Unloadings.
- (v) In the event that a portion of the Available Capacity is the object of two or more Access Requests of equal ranking within the category mentioned under

paragraph (cc) of point (iii) above, priority will be given to the Applicant that, during the requested period, would offer the overall largest volumes of Gas at the virtual exchange point.

- (vi) Available Capacity which has not been allocated pursuant to points (iii), (iv) and (v) above shall be allocated to Applicants undertaking to enter into Non-Foundation Capacity Agreements of a duration lower than five (5) years, in accordance with the ranking priorities indicated under points (iii), (iv) and (v) above.
- (vii) By the 11th (eleventh) of July, or within the following Business Day if the 11th (eleventh) of July is not a Business Day the Operating Company will issue with respect to each Access Request, an Acceptance, a Modified Acceptance, an Interim Notice, or a notice of rejection, as the case may be, in accordance with the following:
 - (aa) *Acceptances*: starting from the highest ranking Access Request, proceeding in order of decreasing ranking and only up to the first Access Request that cannot be Accepted without modification, each Access Request shall be Accepted and the Available Capacity shall be reduced accordingly;
 - (bb) *Modified Acceptances*: if, following the procedure described in the above paragraph (aa), there still are pending Access Requests and Available Capacity, the Operating Company will send a Modified Acceptance to Applicant(s) whose Access Request(s) cannot be Accepted without modification. Any such Modified Acceptance shall be irrevocable until the twenty fourth (24th) of July. In the case all or part of the Available Capacity which is the object of a Modified Acceptance sent to an Applicant pursuant to this paragraph (bb) is also the object of Modified Acceptance(s) sent by the Operating Company to other Applicant(s) with higher ranking Access Request(s), then the Modified Acceptance sent to such Applicant shall provide that, in the case of Acceptance by such Applicant, the resulting Capacity Agreement is subject to the condition precedent that such other Applicant(s) does(do) not Accept its (their) respective Modified Acceptance(s) pursuant to paragraph (v) below;
 - (cc) *Interim Notices*: in the case all or part of the Available Capacity requested by any Applicant is also the object of Modified Acceptance(s) sent by the Operating Company to other Applicant(s) with higher ranking Access Request(s), then the Operating Company shall send such Applicant an Interim Notice; and
 - (dd) *notices of rejection*: each Applicant that is not entitled to receive an Acceptance, a Modified Acceptance, or an Interim Notice pursuant to paragraphs (aa) through (cc) above, shall not be awarded Available Capacity and shall accordingly receive a notice of rejection.
- (viii) Each Applicant receiving a Modified Acceptance shall submit its Acceptance

Courtesy translation, not binding.

to the Operating Company no later than 17:00 hours, on the 24th (twenty fourth) of July. If such Acceptance is not received by the Operating Company by such date, the Applicant shall be deemed to have rejected such Modified Acceptance.

- (ix) The Operating Company shall award the then current Available Capacity in ranking order to the higher ranking Applicant(s) that have Accepted its (their) Modified Acceptances or have received Interim Notices, and the Available Capacity shall be reduced accordingly.
- (x) By the 26th (twenty sixth) of July or within the following Business Day if the 26th (twenty sixth) of July is not a Business Day the Operating Company shall (aa) notify each Applicant that has Accepted, pursuant to paragraph (viii) above, a Modified Acceptance that provides for a condition precedent whether such condition precedent has been met; and (bb) send to each Applicant that has received an Interim Notice the Acceptance or rejection of its Access Request.
- (xi) The Terminal Capacity in any given Month that has been subscribed during the Annual Subscription Process shall be deemed to have been subscribed in the following order:
 - (aa) Terminal Capacity that was, prior to the 1st (first) of June, classified as Unsubscribed Non-Foundation Capacity;
 - (bb) Terminal Capacity that was, prior to the 1st (first) of June, classified as Unsubscribed Foundation Capacity; and
 - (cc) Terminal Capacity that was, prior to the 1st (first) of June, classified as Released Foundation Capacity or Released Non-Foundation Capacity, with such Released Capacity deemed to have been subscribed in the order of the dates of the respective Release Declarations, starting from the earliest.

If, after applying the procedure described in paragraphs (i) through (x) above, the Available Capacity in any given Month of the immediately following Thermal Year is greater than zero and by the 1st (first) of June or within the following Business Day if the 1st (first) of June is not a Business Day of the current Thermal Year the Operating Company had reclassified Unsubscribed Foundation Capacity and/or Released Foundation Capacity in such Month pursuant to paragraph (i) above, then to the maximum extent possible such reclassified capacity shall be converted back to be Unsubscribed Foundation Capacity and/or Released Foundation Capacity, as the case may be, and the Available Capacity shall be reduced accordingly.

- (xii) Following completion of the Annual Subscription Process and by no later than the 27th (twenty-seventh) of July, or the following Business Day if the 27th (twenty-seventh) of July is not a Business Day, the Operating Company shall update the Electronic Communication System accordingly.

Courtesy translation, not binding.

- (xiii) The results of the Annual Subscription Process shall be communicated to the Regulatory Authority for Electricity and Gas within 15 (fifteen) Days from its completion.

- (b) Monthly Subscription Process: each Month, a portion of Available Capacity shall be made available for subscription through the process described below ("**Monthly Subscription Process**"). Such portion of Available Capacity shall be (a) all Available Capacity for the period commencing on the Month immediately following the Subscription Month and ending on the 30th (thirtieth) of September of the immediately following Thermal Year, in the case the Subscription Month is either August or September; or (b) all Available Capacity for the period commencing on the Month immediately following the Subscription Month and ending on the 30th (thirtieth) of September of the then current Thermal Year, in the case the Subscription Month is any Month other than August or September.
 - (i) All Applicants shall submit Access Requests for such Available Capacity by no later than 17:00 hours on the 1st (first) Business Day of the Subscription Month. Any such Access Request shall be irrevocable until 23:59 hours on the 10th (tenth) Business Day of the Subscription Month.
 - (ii) All Access Requests shall be ranked in accordance with the Subscription Allocation Criteria.
 - (iii) By the 3rd (third) Business Day of the Subscription Month the Operating Company will issue, with respect to each Access Request, an Acceptance, a Modified Acceptance, an Interim Notice, or a notice of rejection, as the case may be, in accordance with the following:
 - (aa) *Acceptances*: starting from the highest ranking Access Request, proceeding in order of decreasing ranking and only up to the first Access Request that cannot be Accepted without modification, each Access Request shall be Accepted and the Available Capacity shall be reduced accordingly;
 - (bb) *Modified Acceptances*: if, following the procedure described in the above paragraph (aa), there still are pending Access Requests and Available Capacity, the Operating Company will send a Modified Acceptance to Applicant(s) whose Access Request(s) cannot be Accepted without modification. Any such Modified Acceptance shall be irrevocable until the 6th (sixth) Business Day of the Subscription Month. In the case all or part of the Available Capacity which is the object of a Modified Acceptance sent to an Applicant pursuant to this paragraph (bb) is also the object of Modified Acceptance(s) sent by the Operating Company to other Applicant(s) with higher ranking Access Request(s), then the Modified Acceptance sent to such Applicant shall provide that, in the case of Acceptance by such Applicant, the resulting Capacity Agreement is subject to the condition precedent that such other Applicant(s) does(do) not Accept its(their) respective Modified Acceptance(s) pursuant to paragraph (v) below;

- (cc) *Interim Notices*: in the case all or part of the Available Capacity requested by any Applicant is also the object of Modified Acceptance(s) sent by the Operating Company to other Applicant(s) with higher ranking Access Request(s), then the Operating Company shall send such Applicant an Interim Notice; and
- (dd) *notices of rejection*: each Applicant that is not entitled to receive an Acceptance, a Modified Acceptance, or an Interim Notice pursuant to paragraphs (aa) through (cc) above, shall not be awarded Available Capacity and shall accordingly receive a notice of rejection.
- (iv) Each Applicant receiving a Modified Acceptance shall submit its Acceptance to the Operating Company no later than 17:00 hours on the sixth (6th) Business Day of the Subscription Month. If such Acceptance is not received by the Operating Company by such date and time, the Applicant shall be deemed to have rejected such Modified Acceptance.
- (v) The Operating Company shall award the then current Available Capacity in ranking order to the higher ranking Applicant(s) that have Accepted its (their) Modified Acceptances or have received Interim Notices and the Available Capacity shall be reduced accordingly.
- (vi) By the 8th (eighth) Business Day of the Subscription Month the Operating Company shall (aa) notify each Applicant that has Accepted, pursuant to paragraph (iv) above, a Modified Acceptance that provides for a condition precedent whether such condition precedent has been met; and (bb) send to each Applicant that has received an Interim Notice the Acceptance or rejection of its Access Request.
- (vii) The Terminal Capacity in any given Month that has been subscribed during the Monthly Subscription Process shall be deemed to have been subscribed in the following order:
 - (aa) Terminal Capacity that was, prior to the 1st (first) Business Day of the Subscription Month, classified as Unsubscribed Non-Foundation Capacity; and
 - (bb) Terminal Capacity that was, prior to the 1st (first) Business Day of the Subscription Month, classified as Released Non-Foundation Capacity.
- (viii) Following completion of the Monthly Subscription Process and by no later than the 9th (ninth) Business Day of the Subscription Month the Operating Company shall update the Electronic Communication System accordingly.
- (ix) The results of the Monthly Subscription Process shall be communicated to the Regulatory Authority for Electricity and Gas within the 15th (fifteenth) Day of the Month following the Month within which the Monthly Subscription Process has occurred.

Courtesy translation, not binding.

2.4.3 Subscription of Spot Capacity

Any person meeting the requirements of the Regasification Code may become an Applicant for Spot Capacity published pursuant to clause 2.3 of chapter II by submitting an Access Request to the Operating Company in accordance with the following process ("**Spot Subscription Process**") as set forth herein:

- (a) All Applicants shall submit their Access Requests for Spot Capacity by no later than the due date and time for submission as specified pursuant to letter (iv) of clause 2.3 (e) of chapter II. Any such Access Request shall be irrevocable until 17:01 hours of the latest date by which the Access Request shall be Accepted, as specified pursuant to letter (v) of clause 2.3 (e) of chapter II.
- (b) Access Requests shall be ranked in accordance with the following criteria:
 - (i) ranking priority will be given to the Access Requests requesting the Service for the volume of LNG which most closely matches the maximum volume of LNG which can be Unloaded during the relevant Unloading Slot, as indicated by the Operating Company pursuant to letter (iii) of clause 2.3 (e) of chapter II; and
 - (ii) if any Access Requests are of equal ranking according to the criterion set out in paragraph (i) above, then ranking priority will be given to Access Requests submitted by Applicants utilising Capacity Make Up entitlement, starting with the Access Request of the Applicant with the largest Capacity Make Up Balance and proceeding in order of decreasing size of Capacity Make Up Balance.
- (c) By 17:00 hours on the date specified pursuant to letter (v) of clause 2.3 (e) of chapter II, and subject to letter (d) below, the Operating Company will issue, with respect to each Access Request, an Acceptance or a notice of rejection, as the case may be, in accordance with the following:
 - (i) *Acceptances*: the highest ranking Access Request shall be Accepted; and
 - (ii) *notices of rejection*: each Applicant that has submitted an Access Request with lower than highest ranking shall not be awarded the relevant Spot Capacity and shall accordingly receive a notice of rejection.
- (d) Save for the cases where the Operating Company can use transportation capacity already booked under the Transportation Contract, the Operating Company shall not be bound to Accept an Access Request for Spot Capacity in the event that it has not been able to obtain the necessary transportation capacity by the Transportation Company in order to Redeliver the Gas resulting from the LNG that would be Unloaded by the Applicant.
- (e) If no Access Requests for such Spot Capacity are submitted by the due date for submission of Access Requests, Operating Company will award such Spot Capacity to Applicants on a first come, first served basis.

Courtesy translation, not binding.

- (f) The results of the Spot Subscription Process shall be communicated to the Regulatory Authority for Electricity and Gas within the 15th (fifteenth) Day of the Month following the Month within which a Spot Subscription Process has occurred.

2.4.4 Maximisation of Terminal utilization

With the objective of maximising and optimising the utilisation of the Terminal, the Operating Company may, during the Annual Subscription Process, the Monthly Subscription Process and the Spot Subscription Process, consult with Applicants and Users and seek an agreement between all potentially affected parties in order to accommodate, to the maximum extent possible, all Access Requests. Any agreement so reached between such parties may contain modifications to Access Requests and/or Capacity Agreements of the potentially affected parties. No User or Applicant is under any obligation to enter into any such agreement. If mutual agreement is not reached between all the potentially affected parties, the Operating Company will strictly apply the Annual Subscription Process, the Monthly Subscription Process or the Spot Subscription Process, as the case may be, to allocate the relevant Available Capacity or Spot Capacity. In no case may any such agreement result in an Applicant or a User that is not party to such agreement being in a less advantageous position with respect to the subscription of capacity or the provision of the Service than that Applicant or User would have been in under the Annual Subscription Process, Monthly Subscription Process, Spot Subscription Process or its Capacity Agreement, as the case may be, in the absence of such agreement.

2.4.5 Access Conditions

Unless the Operating Company has waived or deferred compliance with any one or more of the following conditions (to the extent such waiver or deferment is allowed under the applicable Regulations), each Applicant, throughout the period from the delivery of its Access Request until the Acceptance or rejection of such Access Request, must satisfy and maintain all of the following conditions ("**Access Conditions**"):

- (a) there are available to the Applicant one or more importation contracts, and will have quantities of LNG that are the subject of the Access Request and such quantities of LNG must meet LNG Quality Specifications;
- (b) as per art. 10 bis of AEEG resolution 167/05 (as amended by resolution 297/2012/R/Gas) the Applicant whether Transportation User or, in the event the Applicant does not meet this requirement, the Applicant indicates one or more Transportation Users, as per article 10bis.6 of AEEG resolution 167/05 (as amended by resolution 297/2012/R/Gas)
- (c) there is available to the Applicant sufficient LNG Tanker capacity to transport to the Delivery Point the quantities of LNG that are the subject of the Access Request, and such LNG Tanker(s), its (their) crew(s) and captain(s), will be in compliance with the Terminal Regulations, Maritime Regulations, the Cargo Handling Manual and the LNG Tanker Vetting Procedure;
- (d) the Applicant is in compliance with the provisions of clause 10 of chapter III;

Courtesy translation, not binding.

- (e) where any quantity of LNG that is the subject of the Access Request is to be imported from countries outside the European Union, the Applicant has received authorisation granted by MSE for importation of such quantity of LNG pursuant to the provisions set forth in the decree of the MICA (Italian Ministry of Industry, Trade and Crafts) of the 27th of March 2001;

If at any time while the Access Request is pending any Applicant ceases to satisfy or maintain one or more of the Access Conditions, such Applicant must notify the Operating Company within two (2) Business Days after becoming aware of such event.

2.4.6 Access Requests

- (a) Each Access Request for Available Capacity shall include the following information and statements that must remain valid with reference to the Applicant from the date of submission of the Access Request to the signing of the Capacity Contract or the refusal of the Access Request, as appropriate, as well as the documentation specified in clause 2.4.7 of chapter II:
 - (i) the portion of Available Capacity, expressed in cubic metres, requested for each specific Month;
 - (ii) with respect to the requested Available Capacity, the specific number of Unloading Slots for each Month and the quantity of LNG expressed in cubic metres for each such Unloading Slot;
 - (iii) with respect to the Unloading Slots requested, the loading port(s) of the LNG that will be transported to the Delivery Point;
 - (iv) the technical specifications (including the tonnage, gross loading capacity, and length) of the LNG Tanker(s) that will be used to transport the LNG to the Delivery Point;
 - (v) confirmation of the existence of LNG importation agreements compatible as to duration and quantities with the terms of the Access Request specified in paragraphs (i), (ii), (iii) and (iv) above;
 - (vi) confirmation of whether the Applicant meets the requirements necessary to be granted any priority in the allocation of Available Capacity established in paragraph (iii) of clause 2.4.2 (a) above, specifying the type of priority to which the Applicant is entitled;
- (b) Each Access Request for Spot Capacity shall include the following information and statements that must remain valid with reference to the Applicant from the date of submission of the Access Request to the signing of the Capacity Contract or the refusal of the Access Request, as appropriate, as well as the documentation specified in clause 2.4.7 of chapter II:
 - (i) the volume of LNG, expressed in cubic metres, requested for Unloading during the relevant Unloading Slot, specifying:

Courtesy translation, not binding.

- (aa) the technical specifications (including the tonnage, gross loading capacity, and length) of the LNG Tanker that will be used to transport such volume of LNG to the Delivery Point;
 - (bb) the loading port of the LNG that will be transported to the Delivery Point; and
 - (cc) the arrival date of the LNG Tanker;
- (ii) confirmation of the existence of an importation agreement compatible as to duration and quantities with the terms of the Access Request specified in paragraph (i) above;
- (c) If the Applicant for Available Capacity or Spot Capacity is not a company incorporated in one of the member states of the European Union, the Access Request shall be duly notarised by a notary public and legalized or apostilled as may be required under Italian law in order to certify the authenticity of the signature of the notary public, his/her capacity as notary public and, where appropriate, the identity of the seal or stamp which the Access Request bears.

Recognizing that time is of the essence with respect to submission of Access Requests hereunder, a company that is not incorporated in one of the member states of the European Union and intends to submit Access Request(s) may provide, in advance of any such submission:

- (i) evidence satisfactory to the Operating Company that identified representative(s) of such company are duly empowered to execute and submit, in the name and on behalf of such company, (x) such Access Request(s), it being understood that in the case of attorneys in fact (*“rappresentanti negoziali”*), such representatives shall have also been authorised to specifically approve in writing unfair terms (*“clausole vessatorie”*) pursuant to and for the purpose of articles 1341 and 1342 of the Italian civil code and, in particular, the clause derogating the territorial competence referred to under clause 4.2 of chapter I of this Regasification Code, which provides that *“any and all disputes arising out of or in connection with a Capacity Agreement between the Operating Company and the User which is a Party to such Capacity Agreement and/or in connection with the Regasification Code, other than Technical Disputes referred to in clause 4.3 of chapter I, shall be subject to the Italian jurisdiction and to the exclusive competence of the Courts of Milan”*, and (y) the undertaking specified in point (ii) below; and
- (ii) an undertaking of such company to promptly inform the Operating Company as soon as such identified representative(s) are no longer empowered to execute and submit Access Request(s) in the name and on behalf of such company.

The Operating Company shall review the evidence specified in point (i) above and advise the relevant company whether it accepts such evidence as being satisfactory to it. If the Operating Company so advises such company, then such company, for a

Courtesy translation, not binding.

period of 10 (ten) months from the submission of such evidence to the Operating Company, will be entitled to submit Access Request(s) executed by the relevant representative(s) without having to comply with the requirements set forth in the first paragraph of this clause 2.4.6 (c).

- (d) Each Access Request shall express unconditional acceptance by the Applicant of the terms and conditions of the Regasification Code, as well as specific acceptance by the Applicant of the relevant clauses of the Regasification Code pursuant to, and for the purposes of, articles 1341 and 1342 of the Italian civil code.

2.4.7 Documentation to accompany Access Requests

Without prejudice to the requirements of clause 2.4.5 of chapter II, each Applicant shall submit with its Access Request the documents required pursuant to clause 10.1 of chapter III in a form and substance satisfactory to the Operating Company and in addition a self declaration of the import notice or import authorisation required under applicable Regulations for the Applicant to import LNG into Italy.

2.4.8 Execution of Modified Acceptances

The provisions set forth in clauses 2.4.6 (a)(x), 2.4.6 (b)(vi) and 2.4.6 (c) of chapter II shall apply *mutatis mutandis* to the execution of a Modified Acceptance by any Applicant.

2.4.9 Procedure for notification of Access Requests and Modified Acceptances

Each Access Request and each Modified Acceptance shall be notified by the relevant Applicant to the Operating Company in compliance with the requirements set forth in the relevant section of Annex (a).

II.2.5 Access denial

2.5.1 Rejection of Access Requests

In accordance with the provisions of article 24.2 of the Decree, the Operating Company shall have the right to reject any Access Request, notwithstanding that such Access Request meets the requirements set out in the Regasification Code, in each of the following cases:

- (a) the portion of Available Capacity or Spot Capacity (as the case may be) requested by the relevant Applicant has already been awarded in accordance with the Regasification Code or the facilities for Unloading LNG Tankers and/or Regasification and/or Storage is/are not available to provide the Service; or
- (b) the Acceptance of any such Access Request would impede the Operating Company in meeting its obligations to provide a public service, which obligations the Operating Company is required to fulfil pursuant to the Decree.

The Operating Company shall also have the right to reject any Access Request for Spot Capacity, notwithstanding that such Access Request meets the requirements set in the Regasification Code, in the event that the condition under letter (d) of clause 2.4.3 of

Courtesy translation, not binding.

chapter II is not met.

2.5.2 Invalid Access Requests

Any Access Request will be considered invalid if:

- (a) such Access Request (i) has not been drafted in compliance with the form of Access Request provided at Annex (a) and/or (ii) does not include all of the information required by clause 2.4.6 of chapter II and/or (iii) is not accompanied by all of the documentation required by clause 2.4.7 of chapter II; and/or
- (b) the person that has submitted such Access Request does not satisfy all of the Access Conditions from the date of such Access Request until the resulting Capacity Agreement is entered into and the Operating Company has not waived or deferred fulfilment of any such Access Condition pursuant to clause 2.4.5 of chapter II; and/or
- (c) any of the Representations (i) is not true and accurate with respect to the relevant Applicant on the date of such Access Request, or (ii) ceases to be true and accurate with respect to the relevant Applicant before the resulting Capacity Agreement is entered into; and/or
- (d) such Access Request contains any conditions and/or reservations (i) to the acceptance of the terms and conditions of the Regasification Code; and/or (ii) to the specific acceptance by the relevant Applicant of the relevant clauses of the Regasification Code pursuant to, and for the purposes of, articles 1341 and 1342 of the Italian civil code; and/or
- (e) the relevant Applicant has not fulfilled all of its obligations under any Capacity Agreement which such Applicant may have previously entered into with the Operating Company; and/or
- (f) the relevant Applicant seeks access to any portion of Terminal Capacity or Spot Capacity beyond the portion of Available Capacity or Spot Capacity (as the case may be) offered in the relevant subscription process; and/or
- (g) such Access Request fails to meet either of the following requirements:
 - (i) first use of the Service occurs during the current or the immediately following three (3) Thermal Years; or
 - (ii) in the event of Access Requests relating to more than one Thermal Year, the portion of Available Capacity requested by the relevant Applicant with respect to any Thermal Year differs by no more than twenty percent (20%) from the average annual capacity requested by such Applicant, provided that capacity for the first and last Thermal Years for which the Service is requested shall be adjusted pro rata in the case the relevant Applicant is not requesting the provision of the Service for the entire Thermal Year.

2.5.3 Notice of rejection of Access Requests

Courtesy translation, not binding.

Any rejection of an Access Request on any of the grounds set out in clauses 2.5.1 or 2.5.2 of chapter II must be notified by the Operating Company to the Applicant in accordance with the timing set out in clauses 2.4.2 and 2.4.3 of chapter II by way of a written statement setting out the reasons for such rejection. As required by article 24, 2nd and 3rd paragraphs of the Decree, the Operating Company shall send a copy of the notice of rejection to the Regulatory Authority for Electricity and Gas, the Italian Antitrust Authority (*Autorità garante della concorrenza e del mercato*) and the MSE at the same time as sending such notice to the Applicant.

II.2.6 Released Capacity

- (a) Any User that has Subscribed Foundation Capacity and/or Subscribed Non-Foundation Capacity shall have the right to release all or part of such Subscribed Capacity, by notifying to the Operating Company a Release Declaration. Starting from the date that the Release Declaration is received by the Operating Company, (i) such Subscribed Capacity will become Released Foundation Capacity or Released Non-Foundation Capacity, as the case may be, and will be made available for subscription in accordance with clauses 2.4.1, 2.4.2 or 2.4.3 of chapter II, as applicable, and (ii) the Annual Unloading Schedule and the Three (3) Month Schedule of such User shall be revised accordingly. The Operating Company shall update the Electronic Communication System accordingly no later than the first (1st) Business Day after receipt of the Release Declaration.
- (b) The releasing User shall continue to be liable to pay to the Operating Company the Capacity Charge relating to such Released Capacity, but only to the extent that one or more new Capacity Agreements have not been entered into in respect of all or part of such Released Capacity.
- (c) Any User with outstanding Released Capacity may reclaim all or part of such outstanding Released Capacity, provided such reclaimed Released Capacity is not allocated and is scheduled pursuant to the Annual Scheduling Process or Three (3) Month Schedule, by issuing a Reclaim Declaration, as the case may be, to the Operating Company (i) if the Capacity is related to a Slot in the first two weeks of the Month M+1, between the 2nd (second) Business Day and the 5th (fifth) Business Day of the Month M and (ii) if the Capacity is related to a Slot in the last two weeks of the Month M +1, in the period between the 2nd (second) Business Day and the 16th (sixteenth) day of the Month M. For the avoidance of doubt, no User may reclaim any Terminal Capacity during such time as it is reclassified as Released Non-Foundation Capacity pursuant to clause 2.4.2 (a)(i) of chapter II. In addition, the User with outstanding Released Non-Foundation Capacity not subscribed by other Users may not reclaim all or part of such outstanding Released Non-Foundation Capacity between the 1st (first) of June and the 27th (twenty-seventh) of July of each Thermal Year (Annual Subscription Process).

In the case a User has reclaimed Released Capacity pursuant to this clause 2.6 (c), then (i) the relevant Released Capacity shall cease to be Released Foundation Capacity or Released Non-Foundation Capacity, as the case may be, and (ii) the Operating Company shall revise, as applicable, the Annual Unloading Schedule and the Three (3) Month Schedule of such User. The Operating Company shall update the Electronic Communication System accordingly no later than the first (1st)

Business Day after receipt of such written notice.

- (d) Released Foundation Capacity in any given Month may only be subscribed after (i) all the Unsubscribed Foundation Capacity in such Month has been subscribed, and (ii) in the event there is any Unsubscribed Non-Foundation Capacity in such Month, the first Monthly Subscription Process following the relevant Release Declaration has been completed. In the case Released Foundation Capacity or Released Non-Foundation Capacity in any given Month has been released by more than one Foundation Capacity User or Non-Foundation Capacity User, as the case may be, then such Released Capacity shall be subscribed in the same order in which the corresponding Release Declarations have been notified. When entering into one or more new Capacity Agreements with respect to any Month's Released Capacity, the Operating Company shall reduce the Subscribed Capacity of User(s) under the relevant Capacity Agreement(s) accordingly and relieve User(s) of its (their) liability towards such Released Capacity.
- (e) With respect to any Released Foundation Capacity, the Operating Company is under no obligation to enter into a new Foundation Capacity Agreement that contains terms different than those contained in Non-Foundation Capacity Agreements.
- (f) The Operating Company shall notify the releasing User no later than the first (1st) Business Day after the Operating Company has entered into any new Capacity Agreements with respect to the Released Capacity released by such User.

II.2.7 Subscribed Non-Foundation Capacity to be made available to the Operating Company for allocation to third parties pursuant to article 11, sub-section 3, of AEEG Resolution no. 167 of 1 August 2005

2.7.1 Should the volume of LNG Unloaded by a Non Foundation Capacity User in the current Thermal Year be lower than 90% of the volume of the long term ("*pluriennale*") Non-Foundation Capacity allocated to such User for such Thermal Year, such User shall make available to the Operating Company for the allocation to third parties, for each of the following Thermal Years during the which such User holds Subscribed Non-Foundation Capacity, an amount of Non-Foundation Capacity quantified by:

- (a) the volume of capacity, equal to:

$$V_{prio} - V_{cons}$$

where:

V_{prio} is the volume of multiyear capacity allocated to the relevant Non-Foundation Capacity User for the current Thermal Year;

V_{cons} is the overall volume of LNG Unloaded by the relevant Non-Foundation Capacity User during the current Thermal Year, determined as the sum of:

- (i) the volumes of LNG Unloaded during the Months from October to May of the current Thermal Year, including the volumes of LNG that the User did not Unload:

Courtesy translation, not binding.

- (aa) as a consequence of events which have led to force majeure declarations by the counterparties of import contracts, as specified in clause 7.7 of chapter III or to declarations of Force Majeure under the relevant Capacity Agreement;
 - (bb) because the corresponding Non-Foundation Capacity of such User has been Released for allocation to third parties in compliance with the provisions of 2.6 of chapter II, in particular, for each month M of Thermal Year, the volume V_{cons} includes:
 - (bb1) the Released Capacity, even if not allocated, if is made available from the User to the Operating Company before the penultimate Business Day of the month M-3;
 - (bb2) the Released Capacity, insofar as is allocated to third parties, if is made available from the User to the Operating Company after the deadline referred in paragraph bb1 above;
 - (cc) because the corresponding Non-Foundation Capacity of such User has been exchanged with the Non-Foundation Capacity of another User in a different Thermal Year in compliance with the provisions of 12.1 of chapter III.
- (ii) the LNG to be Unloaded during the Months from June to August according to the applicable Three Month Schedule and September according to applicable Annual Unloading Schedule.

In the event that the User holds both long-term and annual Non-Foundation Capacity Agreements, the volume Unloaded shall be allocated, on a priority basis, to the long-term (“*pluriennale*”) Capacity Agreement;

- (b) the number of berthings which can be effected at the Terminal, rounded down to the nearest whole number (“*arrotondato all’intero inferiore*”), equal to:

$$Y = \frac{V_{prio} - V_{cons}}{V_{conf}} \cdot N_{conf}$$

where:

V_{conf} is the overall volume of capacity allocated to the User for the current Thermal Year;

N_{conf} is the overall number of berthings allocated to the User for the current Thermal Year.

2.7.2 As a result of the application of clause 2.7.1, for each one of the Thermal Years during which a User holds long term Subscribed Non-Foundation Capacity, should the difference

Courtesy translation, not binding.

between the Non-Foundation Capacity Subscribed by such User and the Subscribed Non-Foundation Capacity made available for allocation to third parties pursuant to article 11, sub-section 3, of AEEG Resolution no. 167 of 1 August 2005 be lower than V_{cons} , as defined above, such User shall make available for allocation to third parties, pursuant to article 11, sub-section 3, of AEEG Resolution no. 167 of 1 August 2005, an amount of Subscribed Non-Foundation Capacity equal to the difference between the Subscribed Non-Foundation Capacity of such User during Annual and Monthly Subscription Processes and V_{cons} , as defined above.

II.2.8 Subscribed Foundation Capacity to be made available to the Operating Company for allocation to third parties pursuant to article 6, sub-section 3, of the MAP decree of 11 April 2006

- 2.8.1 Should the Subscribed Foundation Capacity of a User not be entirely and constantly used for causes that are dependent on the will of the relevant Foundation Capacity User, the Operating Company shall reallocate to third parties Subscribed Foundation Capacity of such User to the extent required, and in compliance with, article 6, sub-section 3, of the MAP decree of 11 April 2006 and any implementing Regulation, after having notified in advance the MSE and the Italian Regulatory Authority for Electricity and Gas of such reallocations.
- 2.8.2 In calculating the Subscribed Foundation Capacity which has not been used for the purposes of clause 2.8.1 above, the Operating Company shall (i) take into account the start-up period of the Terminal and the flexibilities envisaged by the relevant import contracts, provided that the unused capacity is made available to third parties in accordance with the provisions of regulation n. 715/2009 of the European Parliament and Council of 13th July 2009 and (ii) not consider (“computare”) Subscribed Foundation Capacity which has been Released in accordance with the provisions of clause 2.6 of chapter II and/or transferred in accordance with the provisions of clause 12.2 of chapter III.
- 2.8.3 The Operating Company shall provide to the Ministry of Economic Development and to the Regulatory Authority for Electricity and Gas every year by the month of February the data on the utilization rate of Foundation Capacity and on releases, swaps or transfers of the latter by reference to the Annual Unloading Schedule.

II.3 SCHEDULING OF UNLOADING SLOTS

II.3.1 General principles

Subject to the provisions of the Regasification Code, all scheduling of LNG quantities to be Unloaded at the Terminal shall take into account the operational and maintenance activities of the Terminal (and, to the extent reasonably practicable, the operational and maintenance activities of the Grid), and shall cause, as far as reasonably practicable, a regular and even Unloading sequence that shall be co-ordinated by way of a regular and mutual exchange of information between the Operating Company and each of the Users.

In accordance with the provisions of article 14, sub-section 1, of AEEG Resolution n. 167

Courtesy translation, not binding.

of 1 August 2005, and without prejudice to the provision of clause 3.5 below, the Operating Company and the Transportation Company shall co-ordinate with each other in relation to technical and commercial matters, such as:

- (a) the monthly/weekly/daily programming of Gas to be injected into the Grid;
- (b) the allocation of the Gas injected into the Grid among the various Users;
- (c) the managing of emergencies; and
- (d) the establishment of good practice rules to be adopted for the management of the metering station located immediately upstream of the Cavarzere Entry Point.

In order to reduce the periods of Service disruptions for the Users, the Operating Company and the Transportation Company shall jointly define, in so far as reasonably possible, the scheduling of the maintenance activities on their respective facilities.

The Operating Company shall schedule Unloading Slots in accordance with the procedures set forth herein.

II.3.2 Annual Scheduling

3.2.1 Annual notification by Operating Company

In each Year, by not later than the 15th (fifteenth) of November, or the following Business Day if the 15th (fifteenth) of November is not a Business Day, the Operating Company shall post on the Electronic Communication System the number of and the tentative dates for all Unloading Slots for the coming Year.

3.2.2 Notification by Users of preferred Annual Unloading Schedule

- a) Each Foundation Capacity User and each Non-Foundation Capacity User must submit in writing to the Operating Company by the first (1st) of January of each Year its preferences with respect to the scheduling of Unloading Slots to which such User has subscribed for the Months of April through December of the same Year ("**Annual Schedule Preferences**"), specifying the following:
 - (i) its preferred scheduling of Unloading Slots for each Month, corresponding to such User's Subscribed Capacity for each such Month;
 - (ii) for each Unloading Slot, the approximate quantity of LNG that the User intends to Unload at the Terminal expressed in cubic metres and GJ;
 - (iii) the tentative identity, tonnage, gross loading capacity and length of the LNG Tankers to be used for each Unloading Slot; and
 - (iv) the tentative port of origin of the LNG for each Unloading Slot.

Any Subscribed Capacity for which the relevant User has not submitted in writing to the Operating Company by the 1st (first) of January of the relevant Year its preferences with respect to the scheduling of Unloading Slots shall be deemed to be Released Capacity as if the User had notified on the 11th (eleventh) of January a Release Declaration to the

Courtesy translation, not binding.

Operating Company pursuant to clause 2.6 of chapter II.

- b) If Capacity is (i) allocated after the 1st (first) of January, and (ii) following the monthly subscription process, the new User shall communicate to the Operating Company in writing and within the 1st (first) Business Day of the 1st (first) Month after closing of the monthly subscription process the preferences related to the Unloading Schedule of the Slots that the User has subscribed with reference to the months from April or the 1st (first) month after the month of April in which Capacity has been allocated to December of that year.

3.2.3 Notification by the Operating Company of Annual Unloading Schedules

By not later than the 12th (twelfth) of January of each Year, or the following Business Day if the 12th (twelfth) of January is not a Business Day, the Operating Company shall notify each Foundation Capacity User and each Non-Foundation Capacity User of its Annual Unloading Schedule and shall update the Electronic Communication System, showing which Unloading Slots are assigned and which Unloading Slots have not been assigned.

If the preferences related to the Unloading Slots schedule have been submitted to the Operating Company pursuant to paragraph b) of Article 3.2.2 Chapter II, the Operating Company shall communicate the Annual Unloading Schedule to the User within the first (1st) Business Day of the Month following the Month of communication of the Unloading Slots schedule preferences.

Each Annual Unloading Schedule for the Months of April through December is indicative only, and subject to modification pursuant to clause 3.3 of chapter II. In developing each Annual Unloading Schedule, the Operating Company shall endeavour to schedule the Unloading Slots in a fair manner, taking into account the then current Three (3) Month Schedule and the Annual Schedule Preferences of the relevant User.

Where two or more Users have expressed conflicting preferences with respect to the scheduling of Unloading Slots and such Users are unable to resolve such conflict by way of the regular and mutual exchange of information between the Operating Company and such Users, then the Operating Company, to ensure also regular deliveries and maximum use of the Terminal, shall schedule the relevant Unloading Slots giving priority to the User which is receiving the Service for the largest aggregate quantity, expressed in cubic metres, of LNG over the term of its Capacity Agreement, subject to such User expressing preferences for Unloading Slots in a manner that allows scheduling of Unloading Slots for use by Foundation Capacity Users and Non-Foundation Capacity Users other than such User.

II.3.3 Three (3) Month Scheduling

3.3.1 Notification by Users of preferred Three (3) Month Schedules

- a) Each Foundation Capacity User and each Non-Foundation Capacity User must submit in writing to the Operating Company by 17:00 hours on the sixteenth (16th) Day of each Month its preferences with respect to the scheduling of Unloading Slots to which such User has subscribed for the three (3) Months following the then current Month ("**Three (3) Month Schedule Preferences**"), specifying the following:

Courtesy translation, not binding.

- (i) its preferred scheduling of Unloading Slots for each Month, corresponding to such User's Subscribed Capacity for each such Month; in doing so, each User shall follow the then current Three (3) Month Schedule and the Annual Unloading Schedule as nearly as practicable;
- (ii) for each Unloading Slot, the quantity of LNG that the User intends to Unload at the Terminal expressed in cubic metres and GJ;
- (iii) for each Unloading Slot, the identity and tonnage, gross loading capacity, and length of the LNG Tanker to be used; and
- (iv) the port of origin of the LNG for each Unloading Slot;
- (v) the User or Transportation Users between whom the Gas quantities are fully or partially divided.

Any Subscribed Capacity during Month *M* for which the relevant User has not submitted in writing to the Operating Company by 17:00 hours on the 16th (sixteenth) Day of Month *M-2* its preferences with respect to the scheduling of Unloading Slots shall be deemed to be Released Capacity as if the User had notified on the 20th (twentieth) Day of Month *M-2* a Release Declaration to the Operating Company pursuant to clause 2.6 of chapter II.

- b) User's requests to swap Unloading Slots with unallocated Slots must be sent by written request to the Operating Company (i) if the unallocated Slot is in the first two weeks of the month *M + 1*, between the 2nd (second) Business Day and the 5th (fifth) Business Day of the month *M* and (ii) if the unallocated Slot is in the last two weeks of the month *M + 1*, in the period between the 2nd (second) Business Day and the 16th (sixteenth) Day of the Month *M*.

3.3.2 Notification by the Operating Company of Three (3) Month Schedules

By no later than the 21st (twenty-first) of each Month, or the following Business Day if the 21st (twenty-first) of the Month is not a Business Day, the Operating Company shall notify each Foundation Capacity User and each Non-Foundation Capacity User of its Three (3) Month Schedule and shall update the Electronic Communication System, showing which Unloading Slots are assigned and which Unloading Slots have not been assigned. The Three (3) Month Schedule shall indicate, for each Month, the number of Unloading Slots allocated to each User, together with the volume of LNG expected to be Unloaded, and the date of each Unloading Slot scheduled.

In developing each Three (3) Month Schedule, the Operating Company shall endeavour to schedule the Unloading Slots in a fair manner, taking into account:

- (i) the then current Three (3) Month Schedule;
- (ii) the Three (3) Month Schedule Preferences of the relevant User; and
- (iii) the criteria set forth in paragraphs (a) and (b) below of this clause 3.3.2.

Where two or more Users have expressed conflicting preferences with respect to the

Courtesy translation, not binding.

scheduling of Unloading Slots and such Users are unable to resolve such conflict by way of the regular and mutual exchange of information between the Operating Company and such Users, then the Operating Company shall schedule the relevant Unloading Slots based upon the following criteria:

- (a) no modifications will be made to the allocation of Unloading Slots from the then current Three (3) Month Schedule; and
- (b) if the criterion in paragraph (a) above is not applicable, then priority will be given to the User which is receiving the Service for the largest aggregate quantity, expressed in cubic metres, of LNG over the term of its Capacity Agreement, subject to such User expressing preferences for Unloading Slots in a manner that allows scheduling of Unloading Slots for use by Foundation Capacity Users and Non-Foundation Capacity Users other than such User.

Subject to the terms of the Gas Redelivery Procedure, the Operating Company must include in the Three (3) Month Schedule an estimate of the Gas to be Redelivered to the relevant User and/or to the Transportation Users indicated by the User for own Gas division as per art.10bis.6 of AEEG resolution 167/05 (as amended by AEEG resolution 297/2012/R/Gas), during the following three (3) Month period.

3.3.3 Three (3) Month Schedules are binding

The Three (3) Months Schedule established pursuant to clause 3.3.2 of chapter II, as may be modified from time-to-time pursuant to clause 3.6 of chapter II, shall be binding upon the Operating Company, the Users and the Transportation Users indicated by the User for own Gas division as per art.10bis.6 of AEEG resolution 167/05 (as amended by AEEG resolution 297/2012/R/Gas).

II.3.4 Spot Cargo scheduling

The Spot Unloading Schedule will be determined by the Operating Company on a case by case basis and published in accordance with clause 2.3 (e) of chapter II.

II.3.5 Planning and management of maintenance and inspections

The objective of the planning and management of maintenance and inspections is to ensure all the actions and measures necessary are implemented to maintain the smooth operation and good condition of facilities, services and equipment and ensure the proper and efficient availability of human and material resources.

This chapter describes the ways in which the Operating Company plans maintenance and inspections, manages spare parts and notifies to the Users via the Electronic Communication System of maintenance and inspections of the Terminal.

3.5.1 General Aspects

- (i) The maintenance of the equipment of the Terminal is an activity that the Operating Company has established with reference to the classification of the criticality of each individual piece of equipment;

Courtesy translation, not binding.

- (ii) This activity is described in a five-year maintenance plan (Five-Year Maintenance Plan) which is updated on an annual basis and uses techniques and instrumentation to carry out preventive maintenance and to predict issues and take corrective action to ensure the maximum safety and functionality of the Terminal;
- (iii) The procurement and availability of the main and most critical parts are ensured by a system of stock control to minimize delays in the execution of scheduled or unscheduled maintenance;
- (iv) The main equipment items have been designed to be removed from service for maintenance or replacement (utilizing back up) to avoid system shutdowns during the life of the Terminal. However, some maintenance and checks will require the whole plant shutdown.

When these activities will be necessary they will be incorporated into the annual update of the Five-Year Plan

3.5.2 Additional maintenance actions

When such actions are needed and when they involve equipment and / or processes and connections, in order to ensure safe operations it may be necessary to empty the pipelines for their remediation and / or whole plant shutdown.

The restart of sections of the process systems can involve prolonged periods of cooling of the lines. The maximum duration of these measures is estimated from 2 (two) to 5 (five) days.

3.5.3 Impacts of the maintenance on Capacity Charge

With regard to the maintenance actions, the Operating Company shall schedule a maximum number of days for the plant maintenance amounting to 70 (seventy) for each five-year period (days equivalent to full Terminal Capacity), calculated from the Thermal Year 2010 - 2011, with a maximum number of days scheduled for each Thermal Year of the five-year period of 30 (thirty) (days equivalent to full Terminal Capacity), these values include any additional activities referred in the above paragraph 3.5.2.

In the event these limits are exceeded, Users of Non Foundation Capacity will be entitled to a reduction of the Capacity Charge in proportion to the actual reduction of the regasified quantities.

3.5.4 Communication to Users and co-ordination of inspections

Not later than ninety (90) Days prior to the beginning of each Year, the Operating Company shall discuss with all Users the anticipated scheduled maintenance and/or inspection of the Terminal in order to minimize the negative impact of any resulting downtime on the Unloading of LNG or reduction in the Redelivery of Gas. The Operating Company shall use all reasonable endeavours to avoid scheduling such maintenance and/or inspection during the period starting on the fifteenth (15th) of October of any Year and ending on the thirty-first (31st) of March of the following Year. Provided the provisions of

Courtesy translation, not binding.

article 6.1.4 letter (d) in chapter III and of Annex (k), any maintenance and/or inspection work not subject to programming must be promptly communicated to Users.

II.3.6 Amendments to schedules

Either Party may at any time request changes to the relevant Annual Unloading Schedule, to the relevant Three (3) Month Schedule or to the Spot Unloading Schedule, as the case may be. Should either Party make such request:

- (i) the Operating Company shall implement such requested changes only in the case that the Operating Company reaches an agreement with each User that would be affected by such changes; and
- (ii) each Party will use all reasonable endeavours to agree upon any requested change pursuant to and for the purposes of paragraph (i) above.

II.3.7 Unloading Slot unavailability

3.7.1 Without prejudice to the liability of the Operating Company under clause 14.1 of chapter III, the following shall apply with respect to any period during which one or more of the scheduled Unloading Slots becomes unavailable or, in the Operating Company's reasonable judgement, is likely to become unavailable for any reason ("**Unloading Slot Unavailability Period**"):

- (a) the Operating Company shall promptly give notice to all affected Users of any Unloading Slot Unavailability Period, and shall state in such notice:
 - (i) the dates and times on which such Unloading Slot Unavailability Period has begun or is expected to begin, and is expected to end, respectively;
 - (ii) a detailed description of the reason(s) for the occurrence or expected occurrence of such Unloading Slot Unavailability Period; and
 - (iii) the programme that the Operating Company intends to implement to resume normal performance of the Service to all Users,

it being noted that the information required to be given to the affected Users pursuant to this paragraph (a) may be included in any notice that the Operating Company is required to send to any such affected User pursuant to clause 7.4 of chapter III;

- (b) the Operating Company shall promptly notify to all affected Users (i) any update to the information indicated in paragraph (a) above; and (ii) the end of such Unloading Slot Unavailability Period;
- (c) the Operating Company and all the affected Users will use all reasonable endeavours to agree on the rescheduling of Unloading Slots that would avoid or reduce to the maximum extent possible cancellation of Unloading Slots during such Unloading Slot Unavailability Period;

Courtesy translation, not binding.

- (d) the Operating Company shall determine the number of Unloading Slots within such Unloading Slot Unavailability Period (if any) for which the Operating Company, notwithstanding any rescheduling of the Unloading Slots pursuant to paragraph (c) above, will not be able to provide the Service and will therefore need to be cancelled;
- (e) the Operating Company shall cancel as many Unloading Slots as determined in accordance with paragraph (d) above in the following order:
 - (i) Unloading Slot(s) of User(s) that has (have) tendered a Notice of Readiness after the end of the corresponding Scheduled Arrival Range(s);
 - (ii) Unloading Slot(s) of Spot User(s) that has (have) not yet tendered a departure notice pursuant to clause 2.1 of chapter IV;
 - (iii) Unloading Slot(s) of Spot User(s) that has (have) tendered a departure notice pursuant to clause 2.1 of chapter IV but that has (have) not yet tendered a Notice of Readiness;
 - (iv) Unloading Slot(s) of Spot User(s) that has (have) tendered a Notice of Readiness;
 - (v) Unloading Slot(s) of Non-Foundation Capacity User(s) that has (have) not yet tendered a departure notice pursuant to clause 2.1 of chapter IV;
 - (vi) Unloading Slot(s) of Foundation Capacity User(s) that has (have) not yet tendered a departure notice pursuant to clause 2.1 of chapter IV;
 - (vii) Unloading Slot(s) of Non-Foundation Capacity User(s) that has (have) tendered a departure notice pursuant to clause 2.1 of chapter IV but that has (have) not yet tendered a Notice of Readiness;
 - (viii) Unloading Slot(s) of Foundation Capacity User(s) that has (have) tendered a departure notice pursuant to clause 2.1 of chapter IV but that has (have) not yet tendered a Notice of Readiness;
 - (ix) Unloading Slot(s) of Non-Foundation Capacity User(s) that has (have) tendered a Notice of Readiness;
 - (x) Unloading Slot(s) of Foundation Capacity User(s) that has (have) tendered a Notice of Readiness.

When applying the provision under any one of the paragraphs (i) through (x) above, the Operating Company shall cancel such Unloading Slot(s) starting from the User whose Capacity Agreement is for the smallest aggregate volume of LNG, proceeding in order of increasing volume and up to the User whose Capacity Agreement is for the largest aggregate volume of LNG; and

- (f) the Operating Company shall promptly notify each affected User regarding any rescheduling and/or cancellation of its Unloading Slots during the Unloading Slot

Courtesy translation, not binding.

Unavailability Period.

3.7.2 Following the end of the Unloading Slot Unavailability Period, the Operating Company will reinstate the Three (3) Month Schedules of all Users, effective with the first Unloading Slot following the end of such Unloading Slot Unavailability Period.

3.7.3 In the event that any one or more LNG Tankers of a User:

- (a) were scheduled to Unload during the Unloading Slot Unavailability Period but (i) could not Unload or (ii) Unloaded during an Unloading Slot rescheduled in accordance with clause 3.7.1 (c) of chapter II; and
- (b) are unable to Unload during any Unloading Slot of such User which is scheduled within six (6) weeks after the end of the Unloading Slot Unavailability Period,

then

- (c) such User shall have the right to cancel one Unloading Slot for each such LNG Tanker by giving notice to the Operating Company within five (5) Business Days following the end of the Unloading Slot Unavailability Period; and
- (d) such User shall not have any liability whatsoever to the Operating Company with respect to any Unloading Slot cancelled pursuant to this clause 3.7.3, including any liability to pay any Capacity Charge with respect thereto. Notwithstanding the above, such User shall remain obliged to pay the applicable Grid Capacity Charge with respect to such Unloading Slot unless the relevant Unloading Slot Unavailability Period has been caused by a grossly negligent or wilful act or omission of the Operating Company or its employees, contractors, agents and/or other third parties acting for it or on its behalf (it being understood that in no event shall the Transportation Company be considered a “contractor” or a “third party” acting for, or on behalf of, the Operating Company).

The Operating Company may award to other Users any Unloading Slot that has been cancelled pursuant to this clause 3.7.3.

II.3.8 Additional services

Without jeopardising the Redelivery operating flexibility regulated by article 6.1.4 letter (a) in chapter III and in Annex (k), the Provider may, subject to the technical-operating conditions of the Terminal and rate of use of Final Terminal Capacity, offer the additional services indicated in this article, according to the methods indicated in Annex (o), applying the relevant fees defined in chapter III, article 8, paragraph 1 and published in the Electronic Communication System.

3.8.1 Flexibility Service

Without jeopardising Redelivery operating flexibility regulated by article 6.4.1 letter (a) in Chapter III to Annex (k), the Provider may offer is Users on Day D the possibility to increase or decrease the quantities of Gas to be redelivered on Day D+1 as per the

Courtesy translation, not binding.

Monthly Redelivery Program/Adjusted Monthly Redelivery Program, Spot Redelivery Program/Adjusted Spot Redelivery Program.

The Flexibility Service offer and allocation methods are defined in Annex (o).

3.8.2 Temporary Storage Service

The Operating Company may offer to its Users Temporary Storage of LNG and subsequent Redelivery service.

The Temporary Storage Service offer and allocation methods are defined in Annex (o).

CHAPTER III
GENERAL TERMS AND CONDITIONS
FOR PROVISION OF THE SERVICE

III.1 CAPACITY AGREEMENTS

The Regasification Code is not an offer to the public pursuant to article 1336 of the Italian civil code and is not a promise to the public pursuant to article 1989 of the Italian civil code, but it is an invitation to the public to make offers, which shall be made in accordance with clauses 2.4.2 and 2.4.3 of chapter II.

III.2 SCOPE OF CAPACITY AGREEMENTS AND OBLIGATIONS OF THE PARTIES

III.2.1 Scope of Capacity Agreements

The scope of each Capacity Agreement shall be the provision of the Service by the Operating Company to the User, starting from the date, for the term and with respect to the amount of Subscribed Capacity specified in such Capacity Agreement, and the payment of the related Regasification Service Charge and Redelivery Service Costs by the User to the Operating Company, all subject to and in accordance with the provisions of such Capacity Agreement.

III.2.2 Parties' obligations

2.2.1 Under a Capacity Agreement, the Parties undertake the following obligations:

- (a) the Operating Company must perform the Service, starting from the date, for the term and with respect to the Subscribed Capacity specified in such Capacity Agreement, all in accordance with the provisions thereof; and
- (b) the User must, starting from the date, for the term and with respect to such User's Subscribed Capacity, all as specified in such Capacity Agreement:
 - (i) pay the Capacity Charge and Grid Capacity Charge (if and to the extent due by the Operating Company to the Transportation Company under the Transportation Contract);
 - (ii) in respect of any LNG quantities that such User (in its sole discretion) has delivered, or has procured the delivery of, to the Delivery Point in accordance with such Capacity Agreement and for which the Service has been rendered, (a) accept Redelivery of the Gas or ensure that the Transportation Users as may be specified in accordance with article 10bis6 of AEEG Resolution 167/05 (as amended by the AEEG Resolution 297/2012/R/Gas) accept the Gas redelivery to the User resulting from such LNG quantities at the flow rate at which such Gas shall be Redelivered pursuant to such Capacity Agreement; and (b) pay the Variable Transportation Charge,

in each case save as otherwise expressly provided by this clause 2.2.

2.2.2 If, for any reason, the User does not deliver or procure the delivery of any LNG quantities

Courtesy translation, not binding.

specified in the relevant Capacity Agreement to the Delivery Point, the User shall have no liability whatsoever with respect to such non-delivery, but it shall remain obliged to pay or reimburse the Operating Company:

- (a) the related Capacity Charge, save where the User is relieved of such obligation in accordance with this clause 2.2 and/or any other relevant provision of such Capacity Agreement;
- (b) the related Grid Capacity Charge if and to the extent due by the Operating Company to the Transportation Company under the Transportation Contract and not otherwise recovered by the Operating Company (including recovery through the reallocation of the relevant transportation capacity to any person other than such User), and in any case subject to clause 2.2.5 of chapter III;
- (c) any other related costs and/or expenses incurred by the Operating Company and charged by the Transportation Company under the Transportation Contract that is not caused by willful misconduct or gross negligence of the Operating Company in the management of the Transportation Contract;; and
- (d) any scheduling variance charges due to the Operating Company in accordance with and subject to the provisions set forth in clauses 8.11 and 8.12 of chapter III, as applicable.

2.2.3 Subject to clause 2.2.4 of chapter III, the Capacity Charge payable by the User shall be reduced in accordance with clause 8.1.1 (a)(iii)(aa) of chapter III, if the Operating Company does not provide, or would not have been able to provide, in whole or in part, the Service to such User in accordance with the provisions of the relevant Capacity Agreement.

2.2.4 Should any circumstance or event (including a Force Majeure Event) occur which has the effect of making impossible and/or unlawful, in whole or in part:

- (a) the production, transportation and/or delivery to the Delivery Point of LNG pursuant to any agreement or arrangement entered into between a User and its LNG supplier(s), LNG transporter(s) or shipowner(s); and/or
- (b) the Unloading of LNG at the Delivery Point or the Redelivery of Gas at the Redelivery Point due to a reduction or interruption in or unavailability of the Grid (including for reasons due to any delay or failure by the Transportation Company under the Transportation Contract, Grid maintenance),

the User shall continue to be liable to pay the relevant Capacity Charge and Grid Capacity Charge as if such circumstance or event had not occurred.

It is understood that the above provisions of this clause 2.2.4 shall not apply to the payment of the Capacity Charge:

- (i) with respect to any such circumstance or event which is caused by any act or omission of the Operating Company or any employee, contractor, agent or other third party acting for it or on its behalf (it being understood that in no event shall the Transportation Company be considered as a “contractor”

Courtesy translation, not binding.

or a “third party acting for, or on behalf of, the Operating Company”); and

- (ii) if the Operating Company would not have been able to provide, in whole or in part, the Regasification Service to such User in accordance with the provisions of the relevant Capacity Agreement even if such circumstance or event had not occurred.

2.2.5 It is understood that the amount of the Grid Capacity Charge payable by the User pursuant to clause 8.1.1(e) of chapter III shall be reduced only if, and to the extent that, the Operating Company does not provide, or would not have been able to provide, in whole or in part, the Service to such User as a result of a grossly negligent or wilful act or omission of the Operating Company or its employees, contractors, agents and/or other third parties acting for it or on its behalf (it being understood that in no event shall the Transportation Company be considered as a “contractor” or a “third party acting for, or on behalf of, the Operating Company”).

III.2.3 Service Conditions

Unless the Operating Company has waived or deferred compliance with any one or more of the following conditions (to the extent such waiver or deferment is allowed under the applicable Regulations), each User must satisfy and maintain all of the following conditions ("**Service Conditions**"):

- (a) the User has an unconditional sale and purchase agreement for the quantities of LNG that are the subject of the Capacity Agreement;
- (b) from the start date of the Service, the User (i) has a transportation agreement to transport downstream of the Redelivery Point the quantities of Gas that are the subject of the Capacity Agreement or (ii), in the event that the User is not part of a transportation contract for the quantities of gas which are the object of the Capacity Contract, indicates one or more Transportation Users and certifies to have an irrevocable commitment to withdraw the Gas according to the comma 1 e 6 of article 10bis of AEEG Resolution n. 167/05 as modified by AEEG Resolution n. 297/12;
- (c) the User has an agreement to transport to the Delivery Point the quantities of LNG that are the subject of the Capacity Agreement and the relevant LNG Tanker(s), its (their) crew(s) and captain(s) shall, from the start date of the Service, be in compliance with the Terminal Regulations, Maritime Regulations, the Cargo Handling Manual and the LNG Tanker Vetting Procedure;
- (d) the User is in compliance with the provisions of clause 10 of chapter III;
- (e) the User is in compliance with the provisions of clause 11.2 of chapter III;
- (f) where any quantity of LNG that is the subject of the Capacity Agreement is to be imported from countries outside the European Union, the User has received authorisation granted by MAP for importation of such quantity of LNG pursuant to the provisions set forth in the decree of the Italian Ministry of Industry, Trade and Crafts of the 27th of March 2001 or, in the event of such User having a LNG

import contract which has a duration of less than one year, the availability of strategic storage, in accordance with article 3, sub-section II, letter (d), of the Decree, if and to the extent that such availability is required under article 3, sub-section VI of the Decree;

- (g) the User possesses all other concessions, authorisations, licences, declarations of no objection (*nulla osta*) and permits necessary for the performance of all activities under, connected with and ancillary to, the Capacity Agreement;
- (h) the User is in compliance with its obligations under the agreements entered into by such User with third persons, which are referred to or which relate to the matters described in paragraphs (a) (b), (c), (d), and (e) above and holds the Operating Company harmless of any Transportation System User default indicated by the User as per article 10bis6 of AEEG Resolution 167/05 (as amended by AEEG Resolution 297/2012/R/Gas) that can have direct or indirect consequences on the execution of the Capacity Agreement;
- (i) the User meets the requirements necessary in order to be granted the priority established under paragraph (iii) of clause 2.4.2 (a) of chapter II, as indicated in its Access Request; and
- (j) the User has provided the Operating Company with the authorisation to make requests of transactions at the System which imply the automatic acceptance by the User and/or the Transportation System Users indicated by the User according to article 10bis6 of AEEG Resolution n. 167/05 (as modified by AEEG Resolution n.297/2012/R/Gas), in accordance with the applicable provisions according to the Snam Rete Gas network code, as well as with any other documentation required by Snam Rete Gas or other entity in this respect, it being understood that the authorisation and the other documentation shall be provided by the User and/or the Transportation System Users indicated by the User according to article 10bis6 of AEEG Resolution n. 167/05 (as modified by AEEG Resolution n. 297/2012/R/Gas), in due time in order to allow the Operating Company to provide it to Snam Rete Gas or other entity before the start of the Service.

If at any time during the term of the Capacity Agreement any User ceases to satisfy or maintain one or more of the Service Conditions, or the Transport Service Users indicated by the User as per article 10bis6 of AEEG Resolution 167/05 (as amended by AEEG Resolution 297/2012/R/Gas) cease to meet or maintain one or more of the transportation service access conditions, the User shall (i) notify the Operating Company within five (5) Business Days after becoming aware of such event and (ii) use reasonable endeavours to promptly comply with or satisfy the Service Conditions that are not being maintained or satisfied and, accordingly, take all measures to ensure that the Transportation System User reasonably strives to promptly meet unmet or unmaintained transportation service conditions.

III.2.4 User's representations and warranties

2.4.1 Each User represents and warrants to the Operating Company that the following statements ("**Representations**") are true and accurate as of the date on which the

Courtesy translation, not binding.

Capacity Agreement is entered into:

- (a) it is a company duly organised and validly existing under the laws of its country of incorporation;
 - (b) it has the corporate power and authority to enter into, exercise its rights and perform its obligations under such Capacity Agreement;
 - (c) if the Applicant is a company incorporated under the laws of Italy, the Access Request has been executed by representative(s) for such Applicant who is(are) duly empowered to execute it in the name and on behalf of such company. It is understood that in the case of attorneys in fact (*“rappresentanti negoziali”*), such representatives shall have been authorised to specifically approve in writing the unfair terms (*“clausole vessatorie”*) pursuant to and for the purpose of articles 1341 and 1342 of the Italian civil code and, in particular, the clause derogating the territorial competence referred to under clause 4.2 of chapter I of this Regasification Code, which provides that *“any and all disputes arising out of or in connection with a Capacity Agreement between the Operating Company and the User which is a Party to such Capacity Agreement and/or in connection with the Regasification Code, other than Technical Disputes referred to in clause 4.3 of chapter I, shall be subject to the Italian jurisdiction and to the exclusive competence of the Courts of Milan”*;
 - (d) the Applicant will timely act to be able to operate at the System, unless already able at the date of the Access Request and, will duly execute and timely provide the Operating Company with, the documentation required by Snam Rete Gas or any other entity managing the System, in order for the Operating Company to be authorised to operate at the System by making requests for transactions which imply the automatic acceptance by the Users and/or the Transportation System Users indicated by the User according to article 10bis6 of AEEG Resolution n. 167/05 (as modified by AEEG Resolution n. 297/2012/R/Gas);
 - (e) there are no actions or proceedings pending, or to the best of such User's knowledge, threatened against or affecting such User which would have a material and adverse effect on its ability to perform its obligations under such Capacity Agreement; and
 - (f) the execution and performance of such Capacity Agreement by such User does not conflict with (i) any Regulation or other applicable law, regulation, administrative or judicial provision or such like which apply to such User, or (ii) any other agreement to which such User is a party, or trigger a default under any such agreement.
- 2.4.2 Each User undertakes that the Representations set forth in clauses 2.4.1 (a) and 2.4.1 (b) of chapter III will remain true and accurate with respect to itself until the earlier of: (i) the expiration date of the Capacity Agreement; or (ii) the date on which the Capacity Agreement is terminated or otherwise becomes not effective for any reason including the withdrawal by one of the Parties. If any of the Representations set forth in clauses 2.4.1 (a) and 2.4.1 (b) of chapter III ceases to be true and accurate before the earlier of the dates specified under paragraphs (i) and (ii) above, such User must notify the Operating

Courtesy translation, not binding.

Company within ten (10) Business Days after becoming aware of such event.

2.4.3 Notwithstanding any provision to the contrary herein, in no event shall a User be deemed to have breached the undertaking given under clause 2.4.2 of chapter III as a consequence of such User being adjudicated in any insolvency proceedings other than (i) any of the insolvency proceedings specified under Annex B to the EC Council Regulation No. 1346/2000 of 29 May 2000; and/or (ii) any insolvency proceedings contemplated under the laws of any country that is not mentioned in such Annex B, the purpose of which is winding-up.

III.2.5 Operating Company's standard of performance

The Operating Company shall at all times act in order to maximise the safe and efficient operation of the Terminal. In doing so, the Operating Company shall at all times act (a) in compliance with the provisions of the Regasification Code, (b) in compliance with the provisions of the Transportation Contract and (c) as a Reasonable and Prudent Operator.

III.2.6 User's standard of performance

Each User shall at all times, and shall procure that any Shipowner acting for or on behalf of such User, any person supplying LNG to or on behalf of such User and any Shipowner acting for or on behalf of such supplier, and each employee, contractor, agent and any other third party acting for or on behalf of any of them shall at all times, perform such User's obligations under each Capacity Agreement to which it is a Party (a) in compliance with the provisions of the Regasification Code and (b) as a Reasonable and Prudent Operator.

III.2.7 Refusal of changes in the Service

Notwithstanding article 1661 of the Italian civil code, but subject to the provisions of the Regasification Code, the Operating Company shall have the right to refuse any requests for changes in the performance of the Service by any User or any Applicant.

III.2.8 Performance of the Regasification Service

Subject to clause 5.1.5 and 6.1.8 of chapter III, the Operating Company shall perform the Regasification Service on the aggregate Net Adjusted Unloaded LNG delivered during any given period by or on behalf of any User and shall be obligated to make available at the Cavarzere Entry Point a quantity of Gas containing an amount of energy equal to such aggregate Net Unloaded LNG less the Losses and Consumptions.

III.2.9 Performance of the Redelivery Service

2.9.1 Each User acknowledges that the Operating Company has entered into the Transportation Contract, as required by articles 3 and 6 of the AEEG Resolution no. 168 of 31 July 2006, in order to perform the Redelivery Service to the User, and/or to the Transportation System Users indicated by the User according to article 10bis6 of AEEG Resolution n. 167/05 (as modified by AEEG Resolution n. 297/2012/R/Gas).

2.9.2 In light of the above, each User (i) represents that it has reviewed the Network Codes of

Courtesy translation, not binding.

the relevant Transportation Companies and the form of the Transportation Contract; (ii) ratifies the execution of the Transportation Contract(s) by the Operating Company on its(their) behalf, and the Operating Company's specific written approval under articles 1341 and 1342 of the Italian civil code of the "unfair terms" ("*clausole vessatorie*") contained in the Transportation Contract, and, in particular, the provision derogating the territorial competence referred to under article 5.2.2 of chapter 19 of the network code of Snam Rete Gas and 18.6.2.2 of the network code of Infrastrutture Trasporto Gas SpA, which both provide for the exclusive competence of the Courts of Milan, and the performance of all the related activities, if any, that have been performed by the Operating Company prior to the execution of its Capacity Agreement; and (iii) irrevocably authorises the Operating Company to perform on its behalf all the further activities which are necessary or appropriate to execute under the Transportation Contract and to perform the Redelivery Service to the User, and/or to the Transportation System Users indicated by the User according to article 10bis6 of AEEG Resolution n. 167/05 (as modified by AEEG Resolution n. 297/2012/R/Gas).

2.9.3 The Operating Company shall have no liability whatsoever towards the Users with respect to the performance by the Transportation Company of its obligations under the Transportation Contract. Consequently, the Operating Company shall not be liable for any costs, losses, damages, claims and/or expenses of any kind that the Users should suffer or incur as a result of any act or omission of the Transportation Company that is not caused by willful misconduct or gross negligence of the Operating Company in the management of the Transportation Contract.

III.3 RIGHT OF WITHDRAWAL

III.3.1 Withdrawal by Users

3.1.1 Each User shall have the right at any time to withdraw from any Capacity Agreement to which it is a Party, regardless of whether performance of the Service at that time has already started, upon giving sixty (60) Days prior written notice to the Operating Company. The withdrawal shall be effective upon the expiry of such notice period, it being understood, however, that such withdrawal is subject to clause 3.2 of chapter III and will be without prejudice to the accrued rights and obligations of the Parties in respect of the Service provided prior to, or which is being provided as at the effective date of such withdrawal.

3.1.2 The right to withdraw from a Capacity Agreement granted to a User pursuant to this clause 3.1 shall be without prejudice to the right of a User to seek judicial termination (*risoluzione*) of a Capacity Agreement under Italian law in the event of a failure by the Operating Company to comply with its obligations thereunder.

III.3.2 Payment upon User withdrawal

3.2.1 If a User exercises its right to withdraw from a Capacity Agreement to which it is a Party pursuant to clause 3.1 of chapter III, then pursuant to and for the purposes of article 1671 of the Italian civil code and without prejudice to clauses 3.2.3 and 3.2.4 below, such User must pay to the Operating Company, on the effective date of the withdrawal,

(a) an amount equal to the Net Present Value (as at the effective date of the

Courtesy translation, not binding.

withdrawal) of the aggregate Capacity Charge that would have been payable by such User in the absence of such withdrawal, from the effective date of the withdrawal for the remaining term (being until the expiry date specified in such Capacity Agreement), calculated by reference to the aggregate quantity of LNG corresponding to the remaining Subscribed Capacity under such Capacity Agreement throughout such remaining term, plus

- (b) an amount equal to the Net Present Value (as at the effective date of the withdrawal) of the aggregate Grid Capacity Charge that would have been payable by such User in the absence of such withdrawal, from the effective date of withdrawal for the remaining term (being until the expiry date specified in such Capacity Agreement), calculated by reference to the remaining aggregate quantities of Gas which were to be Redelivered to such User, throughout the remaining term of such Capacity Agreement, net of any portion of such Grid Capacity Charge that is not and will not become due and payable to the Transportation Company following such withdrawal.

3.2.2 The amounts referred to in (a), (b) and (c) above will be calculated on the basis of the *Cqs*, *CMr* and Grid Capacity Charge respectively which are applicable to the withdrawing User as at the effective date of the withdrawal, regardless of the fact that any review or recalculation of the *Cqs*, *CMr* or Grid Capacity Charge would or may have taken place at any time during the remaining term of such Capacity Agreement. The Parties acknowledge that the determination of the amounts set out in this clause 3.2 has been reasonably made with due regard given to: (i) the investment costs borne by the Operating Company for the construction of the Terminal; (ii) the obligations that the Operating Company has assumed under the Transportation Contract on behalf of and for the benefit of the User; and (iii) the effect of the User's withdrawal on the achievement of the Operating Company's economic interests.

3.2.3 Should the Subscribed Capacity which has become available as a result of the withdrawal of a User pursuant to clause 3.1 above and in relation to which such User has made payments to the Operating Company pursuant to letters (a) and (b) of clause 3.2.1 above be subsequently reallocated to another User in whole or in part, the Operating Company shall reimburse the original User the discounted amounts that such User has paid the Operating Company with respect to such reallocated Foundation Capacity and/or Non-Foundation Capacity pursuant to letters (a) and (b) of clause 3.2.1 above, as soon as the Operating Company has reallocated such Foundation Capacity and/or Non Foundation Capacity to the new User.

3.2.4 Should the transportation capacity which has become available as a result of the withdrawal of a User pursuant to clause 3.1 above and in relation to which such User has made a payment to the Operating Company pursuant to letter (c) of clause 3.2.1 above be subsequently reallocated to another User in whole or in part, the Operating Company shall reimburse the original User the discounted amounts that such User has paid the Operating Company with respect to such reallocated transportation capacity, as soon as the Operating Company has reallocated such transportation capacity.

III.4 TITLE

Courtesy translation, not binding.

III.4.1 Title to LNG

The Operating Company has no title to the LNG delivered by or on behalf of such User to the Delivery Point. The User agrees to indemnify, defend, and hold the Operating Company harmless in respect of any costs, losses, damages, claims and/or expenses of any kind suffered or incurred by the Operating Company and arising from any liens, charges, encumbrances and/or adverse claims which may be made by third persons for any reason in respect of such LNG.

III.4.2 No transfer of title in LNG or resultant Gas

Subject to clause 6.2 of chapter III, delivery of LNG to the Delivery Point by or on behalf of a User will not cause any transfer to the Operating Company of any title in such LNG or resultant Gas and the Operating Company shall have custody of such LNG or resultant Gas until the Cavarzere Entry Point only for the purpose of carrying out the Service.

III.4.3 Right to co-mingle

Each User authorises the Operating Company to co-mingle the LNG which is delivered to the Terminal by or on behalf of such User with the LNG of other Users in the storage tanks of the Terminal and to co-mingle the resultant Gas prior to the Redelivery Point.

III.5 QUANTITY AND QUALITY OF LNG

5.1.1 Quantity and quality at the loading port

In order to facilitate the Unloading, each User shall furnish to the Operating Company, as soon as reasonably possible after each loading of an LNG cargo to be Unloaded, but in no event less than twenty-four (24) hours prior to issuance of the relevant Notice of Readiness, a certificate setting forth the quantities, the Gross Heating Value, mol composition analysis, Wobbe Index, and the loading temperature and pressure of the LNG to be Unloaded.

5.1.2 Quality at the Delivery Point

Subject to the following provisions of this clause 5, the quality of LNG delivered by or on behalf of a User to the Operating Company at the Delivery Point shall comply with the LNG Quality Specifications.

Notwithstanding the foregoing, if the Gross Heating Value of LNG to be Unloaded by any User is higher than the limits set forth in the LNG Quality Specifications by reason of Boil-off occurring during a delay in Unloading an LNG Tanker of more than forty-eight (48) hours after the Notice of Readiness has been tendered within its Scheduled Arrival Range in accordance with clause 2.5 of chapter IV, which delay is due to any reason other than those specified in clause 3.8.1 of chapter IV, such LNG shall be deemed to have met the LNG Quality Specifications regarding the Gross Heating Value for all purposes of this Regasification Code. In particular, without limiting the generality of the foregoing, (i) the Operating Company shall endeavour to accept and Unload such LNG, it being understood that clause 5.1.5 of chapter III shall not apply with respect to the Unloading of such LNG and (ii) in the event that the Operating Company is unable to accept and Unload such

Courtesy translation, not binding.

LNG, the Operating Company shall indemnify and hold the User harmless from any costs and/or expenses directly incurred by such User as a result of its inability to accept and Unload the LNG.

5.1.3 Determination of quantity and quality of LNG at the Delivery Point

The quantity and quality of LNG delivered by or on behalf of a User to the Operating Company at the Delivery Point shall be determined in accordance with the following:

- (a) Tank gauge tables of LNG tankers: such User shall furnish to the Operating Company a certified copy of tank gauge tables for each tank of each LNG Tanker as described in Annex (j).
- (b) Gauging and measuring LNG volumes: the quantity of LNG Unloaded shall be determined by gauging the LNG in the tanks of the LNG Tanker immediately before and after Unloading net of any quantity of Boil-off used by the LNG Tanker during the Unloading as fuel in accordance with Directive 2005/33/EC. Gauging the liquid in the tanks of the LNG Tanker and the measuring of liquid temperature, vapour temperature and vapour pressure in each LNG tank, any quantity of Boil-off used by the LNG Tanker and the trim and list of the LNG Tanker shall be performed, or caused to be performed, by such User before and after Unloading. The Operating Company shall have the right to witness and verify such gauging and measuring. Copies of gauging and measurement records shall be furnished to the Operating Company and, in the absence of manifest error, shall be conclusive. Gauging devices shall be selected, and measurements shall be effected, in accordance with Annex (j).
- (c) Samples for quality analysis: representative samples of the LNG shall be obtained by the Operating Company as provided in Annex (j), with one sample being provided to such User.
- (d) Quality analysis: the samples referred to in paragraph (c) above shall be analysed by the Operating Company in accordance with Annex (j), in order to determine the molar fraction of the hydrocarbons and other components in the sample.
- (e) Operating procedures: such User, at no cost to the Operating Company, may procure that all measurement, gauging and analysis conducted pursuant to paragraphs (b), (c) and (d) above are witnessed and verified by an independent surveyor approved by the Operating Company. The Operating Company shall maintain and publish on the Electronic Communication System a list of its approved independent surveyors. For this purpose, the Operating Company shall provide such User the analysis schedule with respect to paragraph (d) above. If such surveyor is not present at the time the measurements, gauging and analysis are to be conducted, such operations and computations will nevertheless be carried out without delay. The results of such surveyor's verifications shall be made available promptly to the Operating Company.

All records of measurement, gauging and analysis and the related computation results shall be preserved by the Operating Company and kept available to such User for a period of no less than three (3) years after such operations and computations have been completed.

Courtesy translation, not binding.

- (f) LNG energy quantity: the Net Unloaded LNG shall be calculated by the Operating Company according to the procedure set forth in Annex (j) and may be verified by the independent surveyor appointed in accordance with paragraph (e) above.
- (g) LNG energy quantity that takes into account the uncertainty of measurement: the Net Adjusted Unloaded LNG shall be calculated multiplying Net Unloaded LNG by the factor (1-FCI) as defined in article 6.3 of paragraph 3 of Chapter III.
- (h) Verification of tank measurement system: such User shall provide to the Operating Company a copy of an independently certified certificate of accuracy with respect to all cargo measurement devices on such LNG Tanker which has been issued within five (5) years prior to the commencement of Unloading.
- (i) Verification of accuracy and correction of errors: permissible tolerances of measuring devices shall be as described in Annex (j). The inaccuracy of any such measuring device exceeding such permissible tolerances shall require (x) the correction of recordings and computations made on the basis of those recordings, as required to correct all errors which occurred during the period in which the inaccuracy of such device exceeded such permissible tolerances or, if such period cannot be determined, the period conventionally agreed by such Parties, and (y) the adjustment of such device. In the event that the period mentioned under point (x) above is not agreed by the relevant Parties, the related correction shall be made for each Unloading of LNG made during the last half of the period from the date of the most recent calibration of the inaccurate device to the date on which such inaccuracy is detected.

5.1.4 Unloading of Off-Spec LNG

If the quality features of any LNG to be Unloaded, which are notified or procured to be notified by a User to the Operating Company in any notice served pursuant to clause 2.1 of chapter IV:

- (a) do not comply with the LNG Quality Specifications, the Operating Company shall use all reasonable endeavours to accept and Unload such Off-Spec LNG. If, notwithstanding the use of all reasonable endeavours by the Operating Company, the Operating Company reasonably believes that it will be unable to perform the Service, then the Operating Company may refuse such Off-Spec LNG and instruct that the relevant LNG Tanker not be Unloaded, by giving notice to such User within twelve (12) hours after receipt of the above notice; or
- (b) comply with the LNG Quality Specifications, but upon Unloading and testing of such LNG at the Terminal such LNG does not comply with the LNG Quality Specifications, the Operating Company shall (i) promptly give notice thereof to the User; and (ii) use all reasonable endeavours to accept and continue Unloading of such Off-Spec LNG. If, notwithstanding the use of all reasonable endeavours by the Operating Company, the Operating Company reasonably believes that it will be unable to perform the Service, then the Operating Company may refuse such Off-Spec LNG and stop the Unloading by giving notice to such User. In addition, the

Courtesy translation, not binding.

User shall have the right to stop at any time the Unloading of such Off-Spec LNG by giving notice to the Operating Company.

5.1.5 User's liability in relation to Unloading of Off-Spec LNG

Subject to clause 5.1.2, second paragraph, point (i) of chapter III, in the event that any Off-Spec LNG is Unloaded by or on behalf of a User with or without the acceptance of the Operating Company, such User shall indemnify and hold the Operating Company harmless from any costs and/or expenses directly incurred by the Operating Company to:

- (a) restore, repair, or replace any part of the Terminal that is damaged as a result of the Unloading of such Off-Spec LNG; and
- (b) satisfy or settle valid third party claims that are brought against the Operating Company as a result of the Unloading of such Off-Spec LNG, provided that the Operating Company, before satisfying or settling any such claim, shall consult with such User and shall take into due consideration any comments of such User in relation to the defence of any such claim.

The Operating Company shall use all reasonable endeavours to minimize the costs and expenses referred to in this clause 5.1.5. Save as expressly described in this clause 5.1.5, the User shall incur no further liability to the Operating Company with respect to such Off-Spec LNG.

If any Off-Spec LNG is refused by the Operating Company in the circumstances described in this clause 5.1.5, the User shall continue to be liable to pay to the Operating Company the Capacity Charge and the Grid Capacity Charge in respect of such Off-Spec LNG.

III.6 QUANTITY, QUALITY AND PRESSURE OF GAS

III.6.1 Redelivery of Gas

6.1.1 Making Gas available at the Cavarzere Entry Point

Pursuant to clause 2.2 of chapter III, the Operating Company undertakes to make available at the Cavarzere Entry Point, in accordance with the Gas Redelivery Procedure, Gas that complies with the Gas Quality Specifications.

6.1.2 Acceptance of Gas

Considering that the Gas will be injected by the Operating Company into the Grid at the Cavarzere Entry Point on behalf of the Users, the Parties agree that the Gas transmitted by the Operating Company to the Cavarzere Entry Point shall be deemed to be (a) accepted by and in the custody of the User for all purposes of the law and the Regasification Code if such Gas is accepted by the Transportation Company, or (b) rejected by the User for all purposes of the law and the Regasification Code if such Gas is rejected by the Transportation Company. For the purposes of this Regasification Code, Gas shall be deemed to be accepted by the Transportation Company if it has crossed the Cavarzere Entry Point.

6.1.3 Gas Redelivery Procedure

Courtesy translation, not binding.

The Operating Company shall Redeliver and the User shall take the Redelivery of Gas, or ensure that the Transportation Users indicated according to article 10bis6 of AEEG Resolution 167/05 (as modified by AEEG Resolution n. 297/2012/R/Gas) accept the Redelivery of Gas, in accordance with the Gas Redelivery Procedure and the Transportation Contract and as specified in the applicable Capacity Agreement, of one hundred per cent (100%) of the quantity of Gas determined pursuant to clause 2.8 of chapter III, subject to clause 6.1.8 of chapter III.

6.1.4 Principles of the Gas Redelivery Procedure

The Gas Redelivery Procedure is based upon the following principles:

(a) subject to subparagraphs (i) and (j) below, the Operating Company shall Redeliver Gas, and each Continuous User shall take Redelivery of Gas, or ensure that the Transportation Users indicated according to article 10bis6 of AEEG Resolution 167/05 (as modified by AEEG Resolution n. 297/2012/R/Gas) accept the Redelivery of Gas each Day on as constant a basis as possible (“*con un profilo quanto più regolare possibile*”) over the duration of any given Month, save for the case where the relevant Users request otherwise in the presence of operational flexibilities in the Redelivery (“*in presenza di flessibilità operative nella Riconsegna*”). By or before the 21st (twenty first) Day of each Month, or the following Business Day if the 21st (twenty first) of the Month is not a Business Day, the Operating Company shall inform each Continuous User (i) of the most regular Redelivery profile and (ii) a Redelivery profile that includes Redelivery for Spot Users should Spot Capacity be allocated. By or before the first Business Day following the communication day, each Continuous User shall inform the Operating Company of his preference between profile (i) and (ii) indicated above. It is understood that should the Operating Company allocate Spot Capacity, it may change the Monthly Redelivery Program or Adjusted Monthly Redelivery Program for Continuous Users who have chosen profile sub (i) and define a new Adjusted Monthly Redelivery Program. Except for cases of wilful misconduct or gross negligence, the Operating Company shall not be liable for the definition of the latter Adjusted Monthly Redelivery Program. The User may request the Operating Company to change the Redelivery Profile for Month M by or before the fourth to the last Business Day of Month M-1, in this case:

- (a) the Operating Company shall implement the requested changes only when the Operating Company reaches an agreement with all Users concerned by these changes; and
- (b) each Party shall make all reasonable efforts to reach an agreement on the requested methods for all intents and purposes of the previous point (i)

Continuous Users can request the Operating Company to make changes to the Monthly Redelivery Program/Adjusted Monthly Program as per that set by article 3.8 in Chapter II;

(b) the volumes Redelivered to the Continuous Users or, if applicable, to the Transportation User/s indicated according to article 10bis6 of AEEG Resolution n. 167/05 (as modified by AEEG Resolution n. 297/2012/R/Gas) during a Month shall

be based upon: (i) the inventory of LNG in the Terminal tanks at the beginning of the Month; (ii) the minimum level of LNG to be maintained in the Terminal tanks at the end of that Month and (iii) the volumes of LNG Unloaded by the relevant Continuous User during that Month, taking into account the maintenance requirements of the Terminal and of the Grid;

- (c) the Operating Company shall Redeliver to Spot Users, and Spot Users shall take Redelivery, or ensure that the Transportation System User/s indicated according to article 10bis6 of AEEG Resolution n. 167/05 (as modified by AEEG Resolution n. 297/2012/R/Gas) accept the Redelivery of Gas, in accordance with the Spot Redelivery Programme and over the duration of the Spot Redelivery Period. The Spot Redelivery Period shall start during the Day after the Day when Unloading commences or at such other time the Operating Company determines that it is required from an operational point of view;
- (d) the Operating Company shall have the option to change a User's daily volume of Redelivered Gas or, if applicable, to the Transportation System User/s indicated according to article 10bis6 of AEEG Resolution n. 167/05 (as modified by AEEG Resolution n. 297/2012/R/Gas) if necessary to effectively manage the volume of LNG in the Terminal, taking into account expected Unloadings of LNG and expected rates of Redelivery of Gas. In the exercise of such option, Operating Company shall use all reasonable endeavours to limit such changes and will communicate to each User any potential modification to the Monthly Redelivery Programme/Adjusted Monthly Redelivery Programme or to the Spot Redelivery Programme/Adjusted Spot Redelivery Programme, as of Annex (k), by 17:00 hours of each Day $d-2$ for Day d ;
- (e) the conditions and procedures by which the Operating Company updates the daily redelivery volume are defined in Annex (k) of the Regasification Code in the paragraphs "Adjusted Monthly Redelivery Programme" and "Adjusted Spot Redelivery Programme";
- (f) according to the provisions in the relevant Capacity Agreement, Transportation Contract and any other applicable regulation or provision published by Snam Rete Gas in the network code, the Operating Company shall communicate, through daily or multi-daily transactions with the System, the Gas quantities that will be injected on a daily basis at the Cavarzere Entry Point on behalf of each User or, if applicable, of the Transportation User/s indicated as per article 10bis6 of AEEG Resolution 167/05 (as amended by AEEG Resolution 297/201/R/Gas) and shall inform the User or, when applicable, the Transportation User/s indicated according to article 10bis6 of AEEG Resolution 167/05 (as amended by AEEG Resolution 297/201/R/Gas) of the Redelivered Gas volumes to that User on each Day. In the event of adjustments to the Users' Redelivery profiles or, where applicable, the Transportation User/s indicated as per article 10bis6 of AEEG Resolution 167/05 (as amended by AEEG Resolution 297/201/R/Gas) during the Month, including the case in which this is due to a late or early arrival of LNG Tankers or a failure to unload, the Operating Company shall make transactions to the System to mirror the Final Redelivery Profiles of all Transportation Users involved but shall not be obliged to make transactions, in the relevant sessions, to adjust the daily or infra-daily Redelivery profile of each involved User;

- (g) the User shall be responsible and shall hold the Operating Company harmless in respect of any costs, losses, damages, claims and/or expenses of any kind incurred by the Operating Company and charged by the Transportation Company under the Transportation Contract, unless such costs, losses damages claims and/or expenses are the consequence of a grossly negligent or wilful act or omission of the Operating Company;
- (h) to the extent that any User's actual Unloaded volumes of LNG differ, in terms of timing and/or quantity, from those expected to be Unloaded according to the most recent Three (3) Month Schedule, including for reasons of late or early arrivals of LNG Tankers, such User shall have its Redelivery of Gas adjusted first, and then, if still necessary after the quantity of Gas to be Redelivered to such User has been adjusted to the maximum extent possible and without prejudice to clauses 3.3 (d) and 3.4 (d) of chapter IV, the other User(s) shall have their Redelivery of Gas adjusted pro-rata based upon the volume of Gas of the Monthly Redelivery Programme/Adjusted Monthly Redelivery Programme advised to be Redelivered to the User for the Day pursuant to clause 6.1.4 (e) of chapter III. If the User has indicated. In the event that the User has indicated the Transportation System Users in accordance with article 10bis6 of AEEG Resolution no. 167/05 (as amended by the AEEG Resolution no. 297/2012/R/Gas) the provisions of this paragraph shall apply *mutatis mutandis* to the latter;
- (i) in the case of a reduction in the ability of the Operating Company to Redeliver Gas as a consequence of an action of a User or a failure by a User to perform any of its obligations under the relevant Capacity Agreement, such User shall have its Redelivery of Gas curtailed first, and then, if still necessary after the quantity of Gas to be Redelivered to such User has been reduced to zero (0), the other Users shall have their Redelivery of Gas curtailed pro-rata based upon the volume of Gas of the Monthly Redelivery Programme/Adjusted Monthly Redelivery Programme of the User for the Day, as advised pursuant to clause 6.1.4 (e) of chapter III. In the case of a reduction in the ability of Operating Company to Redeliver Gas for reasons other than those described above, all Users shall have their Redelivery of Gas curtailed pro-rata based upon the volume of Gas the Monthly Redelivery Programme/Adjusted Monthly Redelivery Programme of the User for the Day, as advised pursuant to clause 6.1.4 (e) of chapter III. In the event that the User has indicated the Transportation System Users in accordance with article 10bis6 of AEEG Resolution no. 167/05 (as amended by the AEEG Resolution no. 297/2012/R/Gas) the provisions of this paragraph shall apply *mutatis mutandis* to the latter;
- (j) should any User's actual Unloaded volumes of LNG differ, in terms of timing and/or quantity, from those expected to be Unloaded according to the most recent Three (3) Month Schedule, including for reasons of late or early arrivals of LNG Tankers or of failure to deliver, the Operating Company shall not be responsible for any costs, losses, damages, claims and/or expenses of any kind which are suffered or incurred by Users and Transportation System Users if indicated by the User according to article 10bis6 of AEEG Resolution n. 167/05 (as modified by AEEG Resolution n. 297/2012/R/Gas), or third parties, including any claims made by other Users for penalties charged by the Transportation Company or storage companies

Courtesy translation, not binding.

for Gas nomination adjustments, except for the case where such costs, losses, damages claims and/or expenses are directly referable to the wilful or grossly negligent failure by the Operating Company to timely operate during the sessions at the System in accordance with clause 6.1.4 (f) of chapter III.

6.1.5 Determination of quantity, quality and pressure of Gas

- (a) The quantity, quality and pressure of Gas Redelivered to the Users shall be determined in accordance with the procedures established by the Transportation Company for the Grid, which are reflected in Annex (h).
- (b) Upon request of a User, the Operating Company shall allow such User to have access to:
 - (i) the Gas metering equipment owned, operated and maintained by the Operating Company, at reasonable hours and at a frequency consistent with the testing and inspection program of the Transportation Company, and at such User's sole risk and expense, for the purposes of: inspection; taking samples of Gas; being present during tests for determining the quantity, quality and pressure of the Gas Redelivered and during the cleaning, installing, changing, repairing, inspecting, calibrating or adjusting of such metering equipment; and
 - (ii) the records and charts relating to the measurement of the quantity, quality and pressure of Gas Redelivered, together with any related calculations.
- (c) All measurement records made by the Operating Company pursuant to this clause 6.1.5 and the related computation results shall be preserved by the Operating Company and kept available to the relevant User for a period of no less than one (1) year after such measurement and computations have been completed. All measurement records made by the Transportation Company and the related computation results shall be preserved by the Transportation Company and kept available to the relevant User as set forth in the Transportation Contract.
- (d) Permissible tolerances of measuring devices owned, operated and maintained by the Operating Company shall be as described in Annex (j). The inaccuracy of any such measuring device exceeding such permissible tolerances shall require (x) the correction of recordings and computations made on the basis of those recordings, as required to correct all errors occurred during the period in which the inaccuracy of such device exceeded such permissible tolerances or, if such period cannot be determined, the period conventionally agreed by such Parties, and (y) the adjustment of such device. In the event that the period mentioned under point (x) above is not agreed by the relevant Parties, the related correction shall be made with respect to the Gas Redelivered during the last half of the period from the date of the most recent calibration of the inaccurate device to the date on which such inaccuracy is detected. Permissible tolerances of measurement devices under the operation and control of the Transportation Company shall be as described in the Transportation Contract.

Courtesy translation, not binding.

- (e) Considering that (x) the Gas will be injected in the Grid at the Cavarzere Entry Point by the Operating Company acting on behalf of the Users and (y) the Operating Company shall have the possibility to make final adjustments to the Redelivery Profiles of each User during the course of the third (3rd) session envisaged by article 7 of the “Conditions for the transfer and exchange of natural gas at the Virtual Exchange Point”, in the event of inaccuracies of the Gas metering equipment which give rise to reconciliations to the definitive balance of the Users made by the Transportation Company after the closure of the third (3rd) session at the Virtual Exchange Point, pursuant to the applicable provisions of the relevant Network Code, unless such inaccuracies are due to the gross negligence or wilful misconduct of the Operating Company, the Operating Company shall not have any liability towards the Users, or the Transportation System Users if indicated by the User according to article 10bis6 of AEEG Resolution n. 167/05 (as modified by AEEG Resolution n. 297/2012/R/Gas), and shall only be required to perform the activities mentioned under letter (d) above and make the necessary invoicing adjustments pursuant to clause 8.1.4 of chapter III.
- (f) All Gas measuring equipment that is used at the Terminal pursuant to this clause 6.1.5 shall be owned, operated and maintained by the Operating Company, unless otherwise required or imposed by any Regulation.
- (g) The Operating Company shall estimate the gain or loss associated with measurement uncertainty on a regular basis and such gains or losses shall be considered as gains or losses in the quantity of Gas and/or LNG specified in clause 1.1 (n) of chapter II.

6.1.6 Off-Spec Gas

If, for any reason, the Operating Company makes available Off-Spec Gas at the Cavarzere Entry Point for Redelivery to a User:

- (a) the Operating Company must promptly notify such User and the Transportation Company; and
- (b) if any quantity of such Off-Spec Gas is rejected by the Transportation Company:
 - (i) the Capacity Charge payable by such User will be reduced pursuant to clauses 8.1.1 (a)(iii)(bb) of chapter III; and
 - (ii) the Grid Capacity Charge payable by the User pursuant to clause 8.1.1 (d) of chapter III shall be reduced if, and to the extent that, the Off-Spec Gas was made available at Cavarzere Entry Point as a result of a grossly negligent or wilful act or omission of the Operating Company or its employees, contractors, agents and/or other third parties acting for it or on its behalf.

6.1.7 Limitation of liability for Off-Spec Gas

Courtesy translation, not binding.

Except in the case of gross negligence or wilful misconduct on the part of the Operating Company, the Parties agree that the Operating Company's sole and exclusive liability in relation to Off-Spec Gas shall be the remedies given pursuant to clause 6.1.6 (b)(i) of chapter III.

The Operating Company shall have no liability whatsoever with respect to Gas that is lost downstream of the Cavarzere Entry Point and User shall only have recourse to those remedies set forth in the transportation agreement of the relevant User and/or deriving from the Transportation Contract with a possible direct action against the Transportation Company.

III.6.2 Losses and Consumption

- (a) Losses and Consumption means the quantity of LNG and/or Gas used by the Operating Company as fuel and for other purposes necessary for maintaining base Terminal operations and for the provision of the Regasification Service, including the quantities of Gas which are typically lost (i) through valves within the Terminal during normal operations and (ii) during maintenance of the Terminal, but excluding the quantity of Gas and/or LNG provided in clause 1.1 (i) of chapter II
- (b) To cover Losses and Consumption a contribution in kind, equal to a percentage value of the Net Adjusted Unloaded LNG delivered, shall be paid by the Users; such percentage value is defined by the Regulatory Authority for Electricity and Gas during the approval process of the tariff proposal of the Terminal Operator as from time to time updated according to article 9 comma 2 of Annex A of the Resolution AEEG n. 438/2013/R/Gas and shall be published in the Electronic Communication System.
- (c) Each User shall transfer to the Operating Company title to such part of its LNG that is required to be used to cover Losses and Consumption at no cost to the Operating Company and in the quantities determined by the Regulatory Authority for Electricity and Gas pursuant to clause 6.2 (b) of Chapter III.

III.6.3 The correction of the measurement uncertainty

- (a) Correction Factor for the Uncertainty of measurement

Inventory Gain and/or Loss is the result of the embedded uncertainties in the chain of energy measurement, expressed in BTU, from the whole Regasification process that results from the monthly energy balance of the Terminal as a result of all the measuring points used for the energy balance (inputs, outputs and inventory).

The Correction Factor for the Uncertainty inventory's Loss and/or Gain adjusts the calculation of the Quantity Unloaded in BTU to take into account potential Inventory Gain and/or Loss.

The FCI_m is calculated by the Terminal for each Month as follows:

Courtesy translation, not binding.

$$FCI_m = \frac{E_m, C_m}{LNG_m} \cdot 100$$

Where: E_m, C_m are monthly Inventory Gain and/or Loss as the case may be, expressed in energy terms (BTU)

LNG_m is the total energy unloaded each months in BTU

m is the in month in question

FCI_m will be negative in the case of a gain and positive in the case of a loss .

With references to every single Unloading during each Month m , the **FCI** will be applied on the basis of the values of the FCI_m related to the previous months $m-2$, $m-3$ and $m-4$.

The FCI it will be applied to the calculation of the energy associated to each Unloading in the Month m as per article 3 of paragraph VI of Annex J.

The Terminal will publish in the Electronic Communication System within the 25th (twenty five) of each Month, or the next Business Day if the 25th is not a Business Day, the FCI to be applied for the calculation of the Net Adjusted Unloaded LNG of the following month.

b) Annual Reconciliation for Inventory Loss and/or Gain.

For the Continuous Users and the Spot Users an **Annual Reconciliation for Inventory Loss and/or Gain** will be performed at least once per Thermal Year and as a minimum by the end of the second month following the relevant Thermal Year.

The Annual Reconciliation for Inventory Loss and/or Gain will be performed communicating to each User the prorata of the total differences between the energy balance over the Thermal Year -1 as of 30th September and the energy balance over the relevant Thermal Year as of 30th September.

As a consequence of the Annual Reconciliation for Inventory Loss and/or Gain the following will be updated where applicable:

- i) the quantity of LNG available in the Terminal's tanks for each Users that the Reconciliation applies,
- ii) the Capacity Charge and/or the Capacity Make-Up Balance as per clause 8.1.2 of Chapter III, if they calculated utilizing values expressed in energy.

III.7 FORCE MAJEURE

III.7.1 Meaning of Force Majeure

Force Majeure means any event or circumstance beyond the reasonable control of the Party claiming such Force Majeure, which could not be prevented by due care of a Reasonable and Prudent Operator and reasonable expense, which has the effect of making performance by such Party of its obligations under its Capacity Agreement, in whole or in part, impossible and/or unlawful ("**Force Majeure**" or "**Force Majeure Event**").

III.7.2 List of Force Majeure Events

Subject to clause 7.1 of chapter III, Force Majeure shall include the following:

- (a) war (whether declared or undeclared), civil war, acts of terrorism, riot, civil disturbance, blockade, insurrection;
- (b) acts of God, explosion, fire, flood, atmospheric disturbance, lightning, storm, typhoon, tornado, earthquake, landslide, soil erosion, subsidence, washout or epidemic;
- (c) any change in a Regulation or other applicable laws, regulations, administrative or judicial provisions or such like, or coming into effect of a new Regulation or other applicable laws, regulations, administrative or judicial provisions or such like, excluding any that concern tax;
- (d) any refusal, revocation, cancellation, or non-renewal of any authorisation, permit, licence and/or concession required by the Affected Party to perform its obligations under the relevant Capacity Agreement;
- (e) loss of, damage to, or any failure of all or part of the Terminal or of the Grid;
- (f) strikes lockouts and other forms of industrial action, except in cases of conflict within the company, declared on occasions which are not the negotiation of collective agreement; and
- (g) any condition or situation which presents an imminent threat of loss or damage to any property, or of danger to the life or health of any person.

III.7.3 Relief for Force Majeure

7.3.1 Should a Force Majeure Event occur, the Party affected by such Force Majeure Event (the "**Affected Party**") shall be relieved of its obligations under the Capacity Agreement to which it is a Party other than: (i) the obligation to make payments when due; (ii) subject to clause 2.2 of chapter III, the obligation of the User to pay the Capacity Charge, the Grid Capacity Charge and any other related costs and/or expenses charged by the Transportation Company under the Transportation Contract; and (iii) the obligations set out in clause 7.4 of chapter III, for as long as and to the extent that the performance of its obligations is rendered impossible and/or unlawful by such Force Majeure Event, and the other Party shall be relieved of its corresponding obligations under the Capacity Agreement to the same extent.

7.3.2 If, as a consequence of a Force Majeure Event that gives rise to a reduction in the Capacity Charge payable by a User pursuant to clause 2.2 of chapter III, Laytime for an LNG Tanker used by or on behalf of such User exceeds a total duration of forty-eight (48) hours, then such User shall be (i) entitled in its sole discretion to stop Unloading and/or to divert such LNG Tanker, provided that this can be done safely, and (ii) relieved from the payment of the Capacity Charge with respect to the quantity of LNG that was scheduled to be Unloaded but was not Unloaded by such LNG Tanker.

III.7.4 Action to be taken on Force Majeure

Should any Force Majeure Event occur, the Affected Party shall:

- (a) promptly give notice to the other Party, by stating:
 - (i) the date, hour and place where the claimed Force Majeure Event has occurred;
 - (ii) a detailed description of the claimed Force Majeure Event;
 - (iii) the effects of the claimed Force Majeure Event; and
 - (iv) the programme that the Affected Party intends to implement to remedy the Force Majeure Event and resume normal performance of its obligations under the relevant Capacity Agreement; and

in addition to paragraphs (i) through (iv) above, where the Affected Party is the Operating Company:

- (aa) the estimated period during which performance of the Service will be suspended or reduced due to the Force Majeure Event;
 - (bb) the Service that the Operating Company reasonably expects will not be performed or will only be partially performed during the period for which the Force Majeure Event and its effects are estimated to last; and
 - (cc) the list of Unloading Slots that the Operating Company reasonably expects it will be able to accommodate during the period for which the Force Majeure Event and its effects are estimated to last, established in accordance with clause 3.7.1 of chapter II;
- (b) upon the expiry of each consecutive thirty (30) Day period following service of the notice pursuant to paragraph (a) above, update the information described in paragraph (a) above by notifying the other Party the following:
 - (i) the developments in the situation;
 - (ii) the actions being taken to remedy the Force Majeure Event and its effects; and
 - (iii) the date on which it is reasonably expected that such Force Majeure Event and its effects will end;
- (c) use all reasonable endeavours (including the incurrence of reasonable expenditure) to overcome the Force Majeure Event and minimise where possible its effects on the performance of such Affected Party's obligations;
- (d) allow or procure the other Party, its employees, contractors, agents and/or other third party representatives (each acting for or on behalf of such other Party and with its specific approval), upon giving reasonable prior notice and at such other Party's sole risk and expense, to have access to the Terminal and/or any other place where the Force Majeure Event has occurred (to the extent that it is within the reasonable

Courtesy translation, not binding.

control of the Affected Party to do so), in order to check and assess the duration and effects of the Force Majeure Event, provided that such access would not present a danger to the life or health of any person; and

- (e) promptly give written notice to the other Party when the Affected Party is again able to perform its obligations under the relevant Capacity Agreements and shall thereupon promptly resume performance of its obligations thereunder.

III.7.5 Termination for extended Force Majeure

7.5.1 If any single Force Majeure Event substantially or totally impairs performance by the Affected Party of its obligations under its Capacity Agreement for a continuous period of time equal to: (i) thirty-six (36) months or more in the case of a Foundation Capacity Agreement with a Total Term equal to or greater than twenty (20) Years; or (ii) twelve percent (12%) of the Total Term in the case of a Capacity Agreement then either Party shall have the right to terminate the Capacity Agreement by giving written notice to the other Party.

7.5.2 If the termination right granted pursuant to clause 7.5.1 of chapter III is exercised by a User, then such User shall pay:

- (a) an amount equal to the Net Present Value (as at the effective date of termination) of the aggregate Grid Capacity Charge that would have been payable by such User in the absence of such termination, from the effective date of termination for the remaining term (being until the expiry date specified in such Capacity Agreement), calculated by reference to the remaining aggregate quantities of Gas which were to be Redelivered to such User, throughout the remaining term of such Capacity Agreement, net of any portion of such Grid Capacity Charge that is not and will not become due and payable to the Transportation Company following such termination. Should the transportation capacity relating to the quantities of Gas which were to be Redelivered to such User and for which such User has made a payment to the Operating Company pursuant to this clause 7.5.2 (a) be subsequently reallocated to another User in whole or in part, the Operating Company shall reimburse the original User the discounted amounts that such User has paid the Operating Company with respect to such reallocated transportation capacity as soon as the Operating Company has reallocated such transportation capacity and the related Grid Capacity Charge to a new User ; and
- (b) in the event that the termination right is exercised on account of a Force Majeure Event which, in accordance with clause 2.2.4 of chapter III, does not reduce the Capacity Charge payable by such User
 - (i) an amount equal to the Net Present Value (as of the effective date of the termination) of the aggregate Capacity Charge that would have been payable by such User in the absence of such termination, from the effective date of termination for the remaining term (being until the expiry date specified in such Capacity Agreement), calculated by reference to the remaining aggregate quantities of LNG which were to be Unloaded under such Capacity Agreement throughout such remaining term and, if it is a Foundation Capacity User

Courtesy translation, not binding.

The amounts referred to in (a) and (b) above will be calculated on the basis of the *Cqs*, the CMr and the Grid Capacity Charge respectively which are applicable to the terminating User as at the effective date of the termination, regardless of the fact that any review or recalculation of the *Cqs*, the CMr or the Grid Capacity Charge would or may have taken place at any time during the remaining term of such Capacity Agreement. The Parties acknowledge that the determination of the amounts set out in this clause 7.5.2 has been reasonably made with due regard given to (i) the investment costs borne by the Operating Company for the construction of the Terminal; (ii) the obligations that the Operating Company has assumed under the Transportation Contract; and (iii) the effect of the User's termination on the achievement of the Operating Company's economic interests.

7.5.3 Should the Subscribed Capacity which has become available as a result of the exercise by a User of the termination right granted pursuant to clause 7.5.1 above and in relation to which such User has made payments to the Operating Company pursuant to point (i) of letter (b) of clause 7.5.2 be subsequently reallocated to another User in whole or in part, the Operating Company shall reimburse the original User the discounted amounts of Capacity Charge that such User has paid the Operating Company with respect to such reallocated Foundation Capacity and/or Non-Foundation Capacity pursuant to point (i) of letter (b) of clause 7.5.2 above as soon as the Operating Company has reallocated to a new User such Foundation Capacity and/or Non Foundation Capacity.

7.5.4 In the event that the Operating Company exercise the right to terminate the Capacity Agreement under Article 7.5.1 above, the Operating Company shall not pay any damages to the Users and / or any third party.

III.7.6 Exclusivity of Force Majeure provisions

The Parties acknowledge and agree that this Regasification Code contains a complete regulation of all aspects relating to Force Majeure and that therefore articles 1463, 1464, and 1672 of the Italian civil code shall not apply to any Capacity Agreement.

III.7.7 Force majeure declared by the counterparties of import contracts

7.7.1 In accordance with the provisions of article 11, sub-section 2, of AEEG Resolution 167 of 1 August 2005, by “events which have led to force majeure declarations by the counterparties of import contracts” it is intended any event, act, fact or circumstance – not attributable to party declaring such force majeure – which renders totally or partially impossible the Unloading of LNG by or on behalf of the User at the Terminal, and which was not possible to prevent or overcome using the diligence of a reasonable and prudent operator.

7.7.2 As soon as a User becomes aware of the occurrence of a force majeure event indicated under clause 7.7.1 above, it shall promptly give notice to the Operating Company and to the Regulatory Authority for Electricity and Gas by sending a self-certification, in the form available on the Electronic Communication System, containing an indication of:

(a) the expected reduction of LNG quantities;

Courtesy translation, not binding.

- (b) the expected duration of the event;
- (c) the actions undertaken to limit the effects of the event on the LNG Unloadings;
- (d) the actions undertaken to make available to other Users the Subscribed Non-Foundation Capacity which would not be used.

7.7.3 It is understood that the preceding clauses 7.7.1 and 7.7.2 are set forth for the sole purposes of clause 2.7 of chapter II.

III.8 INVOICES, PAYMENT AND CAPACITY MAKE-UP

III.8.1 Invoicing by the Operating Company

8.1.1 After the expiry of each Month (the "**Invoice Month**"), the Operating Company will deliver to each User invoice(s) as soon as the elements that allow its/their determination are available, the amounts of which shall be determined as follows:

- (a) *Cqs Charge*. As *Cqs* charge, the product of *Cqs* and the monthly invoiced quantity ("**Monthly Invoiced Quantity**") less any reductions for Capacity Make-Up pursuant to clause 8.10.2 of chapter III. The Monthly Invoiced Quantity shall be the greater of the Quantity Unloaded and the Quantity Scheduled or Released, less the Monthly Adjustment, where:
 - (i) the "**Quantity Unloaded**" means the aggregate Net Adjusted Unloaded LNG that was Unloaded by or on behalf of such User for all Unloading Slots ending within the Invoice Month as determined by the most current User's Three (3) Month Schedule (independent of whether such LNG was Unloaded before, during or after the Invoice Month);
 - (ii) the "**Quantity Scheduled or Released**" shall mean the sum of:
 - the quantity of LNG that was scheduled to be Unloaded by or on behalf of such User during all Unloading Slots ending within the Invoice Month as determined by the most current User's Three (3) Month Schedule; and
 - the quantity of LNG, if any, corresponding to such User's Released Capacity in the Invoice Month based upon the relevant Release Declaration, to the extent such Released Capacity has not been subscribed by any other User or has not been reclaimed by such releasing User pursuant to clause 2.6 (c) of chapter II.
 - (iii) the "**Monthly Adjustment**" shall mean the sum of:
 - (aa) pursuant to clause 2.2.3 and subject to 2.2.4 of chapter III, any quantity of LNG that was scheduled for Unloading during an Unloading Slot ending in the Invoice Month for which the Operating Company did not provide, or would not have been able to provide, in whole or in part,

Courtesy translation, not binding.

the Service in accordance with the provisions of the relevant Capacity Agreement;

- (bb) any quantity of LNG corresponding to the quantity of Off-Spec Gas made available at the Cavarzere Entry Point pursuant to clause 6.1.6 (b) of chapter III and the Losses and Consumption associated with such off Spec Gas
 - (cc) any quantity of Excess Boil-off determined pursuant to clause 3.9 of chapter IV;
 - (dd) any quantity of LNG that was scheduled to be Unloaded during an Unloading Slot ending within the Invoice Month but that was not Unloaded by or on behalf of such User under the circumstances specified in clause 7.3.2 of chapter III; and
 - (ee) any portion of Subscribed Capacity for which an Unloading Slot was cancelled by such User following an Unloading Slot Unavailability Period pursuant to clause 3.7.3 of chapter II.
- (b) *CMr Charge.* As *CMr* charge, the product of *CMr* and the monthly invoiced quantity ("**Monthly Invoiced Quantity**"). The Monthly Invoiced Quantity shall be equal to the difference between: (i) the greater of the Quantity Unloaded and the Quantity Scheduled or Released and (ii) the Monthly Adjustment as defined in clause 8.1.1(a);
- (c) *Demurrage.* Any Demurrage that: (i) has been paid by the Operating Company to any User(s) during the Invoice Month; and (ii) such User is obliged to repay to the Operating Company pursuant to clause 3.8.2 (b) of chapter IV;
- (d) *Grid Capacity Charge.* The Grid Capacity Charge charged by the Transportation Company to the Operating Company with respect to the Invoice Month *m*, defined as the amount of transportation capacity attributable to each User *k* for the Month *m*, will be calculated according to the following formulas:

$$\text{Grid Capacity Charge}_{m}^{k} = \alpha * \text{CP}_{\text{GNL}}^{\text{E}} * \beta^{k} - \text{Quota}_{\text{ADD}}^{k}$$

$$\text{Quota}_{\text{ADD}}^{k} = \max(0; \sum^{k} \beta^{k} - \text{SO}^{\text{MAX}}) * \alpha * \text{CP}_{\text{GNL}}^{\text{E}} * \frac{\beta^{k}}{\sum^{k} \beta^{k}}$$

Where:

α represents the multiplier coefficient applicable by Snam Rete Gas in case of transportation capacity booked on a less than one year basis.

$\text{CP}_{\text{GNL}}^{\text{E}}$ = Monthly Capacity fee charged by the Transportation Company with reference to the Redelivery Point.

β_k = the maximum between [$\text{SO}^{\text{MAX}} * (\text{Subscribed Capacity}^k / \text{Terminal Capacity})$] and the transportation capacity allocated according to AEEG Resolution n. 168/06

Courtesy translation, not binding.

and Resolution ARG/gas 2/10 for the erogation of the Redelivery Service to the same User

$\Sigma^k \beta^k$ represents the sum, during the Month m , of all k Users' β^k

SO^{MAX} = Maximum Daily Send Out as published on the Operating Company's Electronic Communication System (www.adriaticlng.it)

If a User becomes owner of Released Capacity or not used capacity as of chapter II paragraph 2.6, in the calculation of the Grid Capacity Charge it will be considered the relevant multiplier coefficient consistent with the duration of the Released Capacity or not planned capacity.

In the event that the transportation capacity charge charged by the Transportation Company with respect to the Invoice Month is reduced for any reason, the Operating Company shall make adjustments to the Grid Capacity Charge payable by the respective Users based on the facts and circumstances related to such reduction of capacity charge. Furthermore, the Grid Capacity Charge payable by the User shall be reduced in the cases contemplated under, and pursuant to, clauses 2.2.5, 6.1.6 (b) and 6.1.7 (a) of chapter III and 3.9 of chapter IV.

- (e) *Variable Transportation Charge.* As Variable Transportation Charge, the variable transportation charge charged by the Transportation Company to the Operating Company with respect to the Invoice Month, it being understood that the determination of the share of the overall variable transportation charge attributable to each User shall be determined on the basis of the Gas quantities injected into the Grid at the Cavarzere Entry Point on behalf of the User in the Invoice Month, as resulting from the procedure for the Redelivery of Gas established under clause 6.1 of chapter III, compared to the overall quantity of Gas injected into the Grid at the Cavarzere Entry Point by the Operating Company during the same month.
- (f) *Cost of bank guarantees.* Any substantiated costs and/or expenses incurred by the Operating Company to set-up any bank guarantees required under, or to enter into, the Transportation Contract, it being understood that each User shall be charged only a pro-rata portion of such costs and/or expenses determined on the basis of its Subscribed Capacity compared to the total Subscribed Capacity of all Users.
- (g) *Other charges.* Any other substantiated costs and/or expenses, attributable to the User and charged by the Transportation Company to the Operating Company under the Transportation Contract that are not caused by willful misconduct or gross negligence of the Operating Company in the management of the Transportation Contract.
- (h) *Additional service fees.* If the User request additional services as per article 3.8 of Chapter II. Fees for additional services are listed below:
- Service subscription fee (CSS) on an annual, semiannual or monthly basis, that provides access to Flexibility Services and Temporary Storage Services; and
 - Activation fee (CAS and CBO) for the selected service, Flexibility Service or Temporary Storage Service accordingly; and

Courtesy translation, not binding.

- Fee for the erogation (CRF e CRS) for the selected service, Flexibility Service or Temporary Storage Service accordingly.

Specifically:

Flexibility service fees = CSS + CAS + CRF

Temporary Storage Service fees = CSS + CAS + CBO + CRS

Where:

CSS = Flexibility and/or Temporary Storage Service subscription fee, expressed in Euro as published by the Operating Company on the Electronic Communication System.

CAS = Service activation fee as published by the Operating Company on the Electronic Communication Systems, expressed in Euro/n with n equal to the number of selected service activation days, Flexibility or Temporary Storage Service accordingly.

Activation day means:

- for Flexibility Service, the day the service is provided meaning the day in which the Redelivery Program is changed.
- for Temporary Storage Service, each day in which the Redelivery of temporarily stored GNL quantities are requested.

CRF^{S 1,2} = Redelivery fee for flexibility, expressed in Euro and calculated according to the type of subscription (annual, semi-annual or monthly), of the daily Balancing Market (PB-Gas) and requested Flexibility volumes, based on the following formula:

$$CRF = P \times \text{Difference Prices}_{\text{Flexibility}} \times \text{Flexibility volumes}$$

Where:

- P is a function of the type of subscription (annual, semi-annual or monthly) and is published by the Operating Company on the Electronic Communication System;
- Difference Prices_{Flexibility} represents the difference between the Balancing Market price (PB-Gas), as published on the GME site (<http://www.mercatoelettrico.org/it>), on Day D+1 for which the Program Variation is requested by the User and the weighted average of balancing market prices in the compensation period ("PdC" as better defined in Annex o), where the weights are the quantities in compensation in PdC. To calculate the Difference Prices_{Flexibility} for Session 1 as per point a.2) in Annex (o) the balancing market price of PB-Gas session D+1 is considered while for Session 2 as per point a.2) in Annex (o) the balancing market price of PB-Gas session D-1 (locational session) is considered. Should PB-Gas session D-1

Courtesy translation, not binding.

(locational session) prices not be available, the relevant PB-Gas session D+1 prices are used.

- Flexibility volumes = are the quantities of the Program Variation requested in increase or decrease for day D+1 converted into energy using a Gross Heating Value published by the Operating Company on the Electronic Communication System.

CRF will be paid by the User to the Operating Company only in the following cases:

- if the User requests a Program Variation in increase for day D+1 and the Difference Prices_{Flexibility} is positive; and
- if the User requests a Program Variation in decrease for day D +1 and the Difference Prices_{Flexibility} is negative.

It is understood that the Operating Company will invoice the CSS in any case and thus this fee will not be reimbursed if the Flexibility Service is not rendered, due to Terminal technical operating and/or commercial constraints as better described in Annex (o).

$CBO = Cqs \times 0,05\% \times (\text{Volumes in Temporary Storage}) \times (\text{number of Temporary Storage Days})$

The CBO fee will be paid by the User following a request for Temporary Storage Service.

CRS^{S 1,2} = Redelivery fee for temporary storage, expressed in Euro and calculated according to the type of subscription (annual, semi-annual or monthly), of the Balancing Market prices (PB-Gas) and of volumes requested in Redelivery from temporary storage, based on the following formula:

$CRS = P \times \text{Difference Prices}_{\text{Storage}} \times \text{Volumes in Redelivery from Temporary Storage}$

Where:

- P is a function of the type of subscription (annual, semi-annual or monthly) and is published by the Operating Company on the Electronic Communication System.
- Difference Prices_{Storage} represents the maximum balancing market price in the period of Redelivery from Temporary Storage less the average balancing market price in the Request Period "PdR", where PdR represents the period between the Temporary Storage Service allocation Day to the User and the last Day in which the LNG from Temporary Storage is Redelivered.
- Volumes in Redelivery from Temporary Storage are the quantities in Redelivery from temporary storage converted into energy using a Gross Heating Value published by the Operating Company on the Electronic Communication System.

Courtesy translation, not binding.

CRS will be paid by the User only if the Difference Prices_{Storage} is positive.

The relevant PB-Gas session D+1 balancing market prices are used to calculate the Storage Difference Prices_{Storage}.

It is understood that if the User who was allocated Temporary Storage Service does not request Redelivery (and consequently LNG will be regasified at the end of Temporary Storage Service according to Annex k in the Regasification Code) the Operating Company will not invoice the CAS and CRS Flexibility fees.

The User can opt, when subscribing for the Flexibility and/or Temporary Storage Service, for a variable unit fee determined ex-ante instead of the CRF and/or CRS fees.

8.1.2 The invoice shall show detailed calculations with respect to each of the amounts invoiced pursuant to clause 8.1.1 above. In addition, the invoice shall specify the following:

- (a) **"Monthly Make-Up Quantity"**, which shall be equal to (i) the Quantity Scheduled or Released, less the Monthly Adjustment, less the Quantity Unloaded, if the result of such operation is greater than zero, or (ii) zero if such result is not greater than zero;
- (b) **"Monthly Make-Up Euro"**, which shall be the Monthly Make-Up Quantity multiplied by the *Cqs* applicable in that Invoice Month;
- (c) the updated Capacity Make-Up Balance which shall be the Capacity Make-Up Balance from the prior Invoice Month, if any, plus the Monthly Make-Up Euro from the current Invoice Month less any invoice reductions for Capacity Make-Up in the current Invoice Month pursuant to clause 8.10.2 of chapter III; it is understood that as a consequence of the Annual Reconciliation for Inventory Loss and/or Gain as per paragraph 6.3.(b) of chapter III the Capacity Make-Up Balance will be updated, where applicable.

8.1.3 The Operating Company shall have the option to issue one or more separate invoices for the various components referred to in letters (a) through (h) of clause 8.1.1.

8.1.4 With specific reference to the Grid Capacity Charge and the Variable Transportation Charge, should the Operating Company, in accordance with the terms of the Transportation Contract, receive invoices from the Transportation Company associated with the correction of errors contained in previously issued invoices which have already been charged back by the Operating Company to one or more Users pursuant to clause 8.1.1 of chapter III, the Operating Company will issue additional invoices to the relevant Users, in the form of credit notes or additional invoices.

III.8.2 Due date for invoices

Courtesy translation, not binding.

Each invoice delivered pursuant to clause 8.1.1 of chapter III shall become due and payable by the User twenty (20) Days after the date on which such User receives the invoice.

III.8.3 Payment Instructions

- 8.3.1 All payments pursuant to a Capacity Agreement shall be made in Euro save for payments of any Demurrage, which will be made in USD.
- 8.3.2 Any payments shall be credited by the appropriate due dates by wire transfer to the bank accounts as designated by the Operating Company without any discount associated with the transfer of moneys and at the expense of the User, except that any expenses charged by the Operating Company's bank with respect to such payments shall be borne by the Operating Company.
- 8.3.3 The bank account shall be nominated by Operating Company in a notice to the User. Such nomination shall remain in effect unless changed by notice signed by a duly authorized representative of the Operating Company.

III.8.4 Suspension of payment of invoices

Except in the case of any material manifest error in an invoice, pursuant to and for the purposes of article 1462 of the Italian civil code, a Party shall not be entitled to postpone or suspend the payment of any invoice by reason of any claims, complaints or objections against the other Party or by reason of any pending dispute with the other Party.

III.8.5 Default interest

If payment of any invoiced amount is delayed beyond the due date, then default interest must be paid by the relevant Party to the other Party for every Day of delay from and including the Day following the payment due date up to and including the Day on which payment is actually made, at an interest rate of EURIBOR (as in effect on the Day following the payment due date and as in effect on the first Day of every Month thereafter) plus two per cent (2%). If the default interest so determined exceeds the limit determined by the *Ministero dell'Economia e delle Finanze* pursuant to law no. 108 of 7 March 1996, such default interest shall be payable at the maximum rate permitted by Italian law.

III.8.6 Adjustment of Errors

- 8.6.1 If an error is found by either Party in the amount shown due in any invoice delivered pursuant to clause 8.1.1 of chapter III, and a notice of claim in respect of that error is given to the other Party within one hundred and ten (110) Days following the date of issuance of such invoice, the Operating Company shall issue a statement of adjustment as soon as reasonably practicable after the error is detected. Any adjustment between the User and the Operating Company in respect of the error, together with interest on the amount of such adjustment from and including the Day following the payment due date of the original invoice up to and including the Day on which payment of the amount of such adjustment is actually made, at an interest rate of EURIBOR (as in effect on the Day following such payment due date and as in effect on the first Day of every Month thereafter) plus one per cent (1%), shall be paid:

Courtesy translation, not binding.

- (a) in the case of an error that would result in an adjustment in favour of the Operating Company, within ten (10) Days of the User receiving the statement of adjustment; and
 - (b) in the case of an error that would result in an adjustment in favour of the User, within ten (10) Days after Operating Company has sent the statement of adjustment.
- 8.6.2 Any invoice delivered pursuant to clause 8.1.1 of chapter III which is not disputed in accordance with clause 8.6.1 of chapter III shall be deemed as finally accepted by the Parties except as provided for in clauses 5.1.3 (h) and 6.1.5 (d) of chapter III.
- 8.6.3 If an error in the amount of the Grid Capacity Charge and / or Variable Transportation Charge provided on the invoice is caused by the Transportation Company, the User or Users involved may act directly against the Transportation Company.

III.8.7 No deduction of taxes; liability for Maritime Charges

Each User shall procure that the Operating Company receives the Regasification Service Charge, the Redelivery Service Costs and the Additional Charges payable by such User and any other payments which may be payable by such User under its Capacity Agreement, free of any deductions on account of any taxes and charges of any kind whatsoever, including Maritime Charges for which such User shall be liable. Any Maritime Charges paid by the Operating Company, in respect of the LNG delivered by or on behalf of a User, will increase the amount of the Additional Charges payable by such User and, therefore, shall be invoiced to such User following the incurrence of such Maritime Charges.

III.8.8 Adjustments to the applicable tariffs

Any adjustments to payments of the Regasification Service Charge provided for by any Regulation shall be made in an invoice submitted following the effective date of such Regulation, subject to and in accordance with the terms of such Regulation.

III.8.9 Annual Reconciliation Calculation

- 8.9.1 The Operating Company shall deliver to each User, as soon as practical (a) after the end of each Thermal Year and (b) upon the expiry of the relevant Capacity Agreement, a statement which shall specify the annual reconciliation amount of Capacity Charge, if any, due by such User to the Operating Company as determined pursuant to the following formula ("**Reconciliation Statement**"):

$$SQ = SC - AIQ - AA + RU$$

Where:

SQ = the shortfall quantity of LNG from which the amount due by such User to the Operating Company shall be calculated;

Courtesy translation, not binding.

- SC = the amount of Subscribed Capacity under the relevant Capacity Agreement with respect to the relevant Thermal Year or period, as may have been modified pursuant to any provision of the relevant Capacity Agreement;
- AIQ = the sum of the Monthly Invoiced Quantities for the relevant Thermal Year or period;
- AA = the sum of the Monthly Adjustments for the relevant Thermal Year or period plus any quantity of LNG associated with an Unloading Slot for which the Operating Company failed to schedule within the period of time specified in clause 3.3.2 of chapter II or clause 3.2.3 of chapter II;
- RU = the round-up carried over from the previous Reconciliation Statement, if any, as determined in accordance with this clause 8.9.

If, after applying the formula above, SQ is a negative number, SQ shall be deemed to be zero (0) for the purpose of the Reconciliation Statement.

If, after applying the formula above, SQ is a positive number but is less than the largest quantity of Net Adjusted Unloaded LNG from any LNG Tanker of such User in such Thermal Year, then SQ shall be considered as round-up (in accordance with the formula above) and carried forward to the Reconciliation Statement for the following Thermal Year or period. In such case, SQ shall be deemed to be zero (0) for the purpose of the then current Reconciliation Statement. This paragraph shall not apply to the Reconciliation Statement associated with the expiry of a Capacity Agreement.

Following calculation of SQ pursuant to the formula above, the amount due by such User to the Operating Company pursuant to the Reconciliation Statement shall be determined pursuant to the following formula:

$$SP = (Cqs \times MSQ)$$

Where:

- SP = the amount due by such User to the Operating Company;
- MSQ = the quantity of LNG determined in accordance with the first formula set out in this clause 8.9 unless deemed to be zero (0) pursuant to the provisions of this clause 8.9.1.

The Reconciliation Statement shall show detailed calculations (in accordance with the formulae above) with respect to the amount specified therein. If SP is a positive amount, the Operating Company will also send to such User, together with the Reconciliation Statement, an invoice for the amount specified in such Reconciliation Statement.

- 8.9.2 Prior to sending an invoice to a User pursuant to clause 8.9.1 of chapter III, last paragraph of chapter III, the Operating Company shall update the Capacity Make-Up Balance of such User, by adding to it the amount specified in such invoice.

III.8.10 Capacity Make-Up

If, at any time, the Capacity Make-Up Balance of a User is greater than zero (0), such User may submit a request to the Operating Company to apply all or part of such Capacity Make-Up Balance against utilisation of Terminal Capacity according to the process described below ("**Capacity Make-Up**").

8.10.1 Subscription for Capacity Make-Up

Any User may request as Capacity Make-Up (i) Available Capacity or Spot Capacity by submitting an Access Request in accordance with the procedures set forth by clauses 2.4.2 and 2.4.3 of chapter II and (ii) Unsubscribed Foundation Capacity or Released Foundation Capacity by submitting a written request to the Operating Company, provided that such User has scheduled all of its Subscribed Capacity and has not released any of such Subscribed Capacity under the relevant Capacity Agreement for the Year for which it is submitting such request.

The Operating Company shall process any Access Request for Available Capacity or Spot Capacity as Capacity Make-Up in accordance with the procedures set forth by clauses 2.4.2 and 2.4.3 of chapter II. The Operating Company will use reasonable endeavours to accommodate any request to use Unsubscribed Foundation Capacity as Capacity Make-Up, subject to such request being received by the Operating Company no more than sixty (60) days prior to the beginning of the Unloading Slot(s) associated with such Unsubscribed Foundation Capacity.

8.10.2 Capacity Make-Up invoices

In the event that a User has been granted any Capacity Make-Up:

- (a) the amount for the Capacity Charge in the invoice issued pursuant to clause 8.1.1 of chapter III shall be reduced by the lesser of (i) the then current Capacity Make-Up Balance and (ii) the Capacity Charge related to the quantity of LNG which is the object of such Capacity Make-Up;
- (b) the amount for the Redelivery Service Costs in the invoice issued pursuant to clause 8.1.1 of chapter III shall not be adjusted;
- (c) subject to clause 8.10.3 of chapter III, the Capacity Make-Up Balance will be adjusted by deducting the part of the Capacity Make-Up Balance applied against the amount for the Capacity Charge pursuant to paragraph (a).

8.10.3 Failure to Unload Capacity Make-Up LNG

If a User does not Unload any quantity of LNG which is the object of Capacity Make-Up, then the Capacity Make-Up Balance will not be adjusted pursuant to clause 8.10.2 (c) of chapter III, provided that such User has used all reasonable endeavours to Unload such quantity of LNG.

8.10.4 No Capacity Make-Up following the end of a Capacity Agreement

If at the expiry of, withdrawal by either Party from, or termination of a User's Capacity

Courtesy translation, not binding.

Agreement the Capacity Make-Up Balance with respect to such Capacity Agreement is greater than zero (0), such User will not be entitled to any extension of such Capacity Agreement for the purpose of recovering the related outstanding Capacity Make-Up, nor will it be entitled to claim or recover any compensation for loss of such outstanding Capacity Make-Up.

III.8.11 Charges for scheduling variance applicable to Continuous Users

8.11.1 Scheduling variance charges with respect to the LNG volumes scheduled during Month M-2 and Unloaded during Month M

Should a User's aggregate Net Adjusted Unloaded LNG during a Thermal Year be lower than the aggregate LNG volumes scheduled for Unloading during such Thermal Year, the Operating Company will apply and the User shall pay a charge for scheduling variance as determined in accordance with the formulas below, it being understood that such charge shall be payable by such User only if and to the extent it is due to the Operating Company under applicable Regulations. Formula 1 determines whether a charge for scheduling variance is due and Formula 2 determines the amount of such charge, if applicable.

Formula 1

$$IF : (PQ - AQ) > (0.10 * PQ),$$

Where:

PQ = Aggregate annual scheduled quantities of LNG (m³) set forth in Month M-2 in each of the Three (3) Month Schedules applicable during the relevant Thermal Year;

AQ = Aggregate Net Unloaded LNG (m³) during the relevant Thermal Year,

then Formula 2 shall apply.

Formula 2

$$SVC(€) = 4.5 \times [(PQ - AQ) - (0.10 \times PQ)],$$

Where:

$SVC(€)$ = Scheduling Variance Charge (Euro).

8.11.2 Failure to Unload due to Force Majeure Events

Should any non-delivery of LNG that was scheduled to be Unloaded by or on behalf of the relevant Continuous User be caused by a Force Majeure Event or any failure by the Operating Company to provide in whole or in part the Service, then, provided that such User has complied with its obligations pursuant to clause 7.4 of chapter III (if applicable), the volume of LNG which was not Unloaded due to the above circumstances shall not be

Courtesy translation, not binding.

taken into account in calculating the annual variance charges of such User pursuant to the two formulas in clause 8.11.1 above.

III.8.12 Charges for scheduling variance applicable to Spot Capacity

8.12.1 Calculation of scheduling variance charges

- (a) Should the Net Adjusted Unloaded LNG by a Spot User be lower than the volume of LNG corresponding to the Spot Capacity subscribed under the relevant Spot Capacity Agreement by more than ten percent (10%), the User shall pay a scheduling variance charge. Such charge shall be equal to 4.5 Euro/m³ of LNG multiplied by the difference between the variance and ten percent (10%) of the volume of LNG subscribed under the Spot Capacity Agreement.
- (b) Should the Net Adjusted Unloaded LNG of a Spot User be higher by more than ten percent (10%) of the volume of LNG corresponding to the Spot Capacity subscribed under the relevant Spot Capacity Agreement such Spot User shall pay, in addition to the Regasification Service Charge payable on the additional volumes of Net Unloaded LNG, a charge equal to ten percent (10%) of the *Cqs*, calculated on such difference.

8.12.2 Failure to Unload due to Force Majeure Events

Should any non-delivery of LNG that was scheduled to be Unloaded by or on behalf of the relevant Spot User be caused by a Force Majeure Event or any failure by the Operating Company to provide in whole or in part the Service, then, provided that such Spot User has complied with its obligations pursuant to clause 7.4 of chapter III (if applicable), it shall be relieved of its obligation to pay the variance charges envisaged under clause 8.12.1 (a) above.

III.8.13 Invoicing of scheduling variance charges

The Operating Company shall issue an invoice with respect to any scheduling variance charges due by a User pursuant to clauses 8.11.1 and 8.12.1 above. Such invoice shall be paid by the relevant User in accordance with the provisions applicable to the payment of invoices as set forth in this Regasification Code.

III.8.14 Invoicing of Losses and Consumption

With regard to the amounts of Gas to cover the Losses and Consumption, pursuant to clause 8.1.2(e) of chapter III, the User shall issue each Month an invoice subject to VAT debiting the Operating Company for a conventional price for the transfer of Gas using the tariff term $C_{MEM,t} + CCR$ (as determined periodically by the Regulatory Authority for Electricity and Gas). The Operating Company shall debit back the User by issuing an invoice subject to VAT for the same amount indicated in the above mentioned User's invoice

III.8.15 Invoicing of quantities of gas to be paid in kind to the transportation company to cover the needs of consumption, network and gas losses.

Courtesy translation, not binding.

In compliance with Resolution ARG / gas 184/09 e 192/09 of the Regulatory Authority for Electricity and Gas each User is required to pay in kind to the Transportation Company through the Operating Company, the quantities of gas (expressed in GJ) to cover the needs of consumption, network and Gas losses.

The share of the User (in GJ) for the Month M shall be notified by the Operating Company to the Users at the same time as the Final Redelivery Profile within the 2nd (second) Business Day of month M+1. Differences on the amounts paid to the Transportation Company, if any, will be subject to adjustments through issuance of invoices and / or credit notes. The User must issue a VAT invoice to the Operating Company for the portion for the month M, by the 3rd (third) working day of the month M+2 for the assignment of gas withdrawn by the Transportation Company, determined on the basis of value of Gas as foreseen by the Transportation Company procedure for the same month M according to the Resolution 181/2012/R/Gas.

The User shall send the invoice to the Operating Company in "pdf" format at the following e-mail address which may be updated from time to time: amministrazione.clienti@adriaticlng.it

The Operating Company will charge the User for the same amounts through a VAT invoice in PDF format sent , to email address provided in the Capacity Agreement.

III.9 TAXES, DUTIES AND CHARGES ON THE GAS

III.9.1 Fiscal Compliance

Except as otherwise provided for by the Regulations or by any other applicable laws, regulations, administrative or judicial provisions or such like, all tax returns, filings and/or other formalities of a fiscal or administrative nature required to be made pursuant to any Regulation (including any returns, filings and/or formalities concerning the importation of LNG and/or the injection of the Gas into the Grid) or pursuant to any other applicable law, regulation, administrative or judicial provision of such like, will be borne by and be the responsibility of each User.

III.9.2 Liability for tax obligations

The Operating Company has the right to seek compensation against the User for any and all tax and/or administrative liability deriving from omitted, late and/or untrue declarations, returns and/or failure to fulfill administrative or fiscal obligations that are under the responsibility of the User.

The Operating Company shall not be liable for any delays in the execution of the scheduled Unloading and the following caused by a delay in the performance of customs fulfillments.

No Party will be liable (either as principal debtor or as jointly liable debtor) for any fiscal liability of the other Party.

III.9.3 Payment of duties, and taxes (including VAT)

Any duty and/or tax arising or imposed under Italian law, laws of the European Union or

Courtesy translation, not binding.

under any law of any other state (including VAT) in relation to (a) any LNG of a User, (b) the Service (but excluding, for the avoidance of doubt, any corporation or similar taxes on the revenues or profits of the Operating Company), (c) any LNG regasified for or on behalf of a User, and/or (d) any Gas resulting from Regasification which is transmitted to the Redelivery Point, will be borne by such User, which will keep the Operating Company indemnified in respect of any such duties and taxes.

9.3.1 Value Added Tax

To any compensation relating to and/or resulting from the application of this Regasification Code, the Operating Company will apply VAT in accordance with the rules in force at the time.

9.3.2 Excise duty on natural gas

The consumptions of natural gas on the Terminal are not considered subject to excise duty, being outside the scope of excise duty .

9.3.3 Additional Regional tax on natural gas

The additional regional duty (or the substitute tax) on natural gas does not apply as consumptions of natural gas are outside the scope of excise duty .

III.9.4 Administrative Documentation

In compliance with current legal requirements the results of the qualitative analyses on natural gas, carried out on the Terminal, are available to the competent Customs Offices.

All the documentary evidence related to the import of User's natural gas, including the filing of documents, shall be the exclusive responsibility of the User.

III.10 GUARANTEES

III.10.1 Financial security for User's obligations

In accordance with the terms of this Regasification Code, the Operating Company will provide the Service only to Users that provide and maintain adequate financial security for their respective obligations under the Capacity Agreement to which they are a Party for the term of such Capacity Agreement. For this purpose, upon submission of an Access Request (or, as the context may require, in clauses 10.1 (b), 10.1 (c) and 10.1 (d) of chapter III, prior to entering into a Capacity Agreement with the Operating Company), the Applicant must provide to the Operating Company:

- (a) written evidence in a form and substance satisfactory to the Operating Company that the credit rating of the Applicant with reference to its long term unsecured and unguaranteed debt is equal to or higher than:
 - (i) Baa3 if provided by Moody's; or
 - (ii) BBB- if provided by S&P; or

- (b) if the requirements of clause 10.1 (a) of chapter III are not met by the Applicant (or were met by the Applicant at the time of submission of its Access Request but subsequently ceased to be met prior to such Applicant entering into a Capacity Agreement with the Operating Company in respect of such Access Request), but such requirements are met by such Applicant's Parent Company, a First Demand Parent Company Guarantee issued by the Applicant's Parent Company; or
- (c) if:
 - (i) the requirements of clause 10.1 (a) of chapter III are not met by the Applicant (but may have been met by the Applicant's Parent Company at the time of submission of the Applicant's Access Request but such Parent Company subsequently ceased to be the Parent Company of the Applicant prior to the Applicant entering into a Capacity Agreement with the Operating Company in respect of such Access Request); and
 - (ii) no company directly or indirectly controls the Applicant for all legal purposes of article 2359, sub-section I, number (1) of the Italian civil code, but the requirements of clause 10.1 (a) of chapter III are met by any person that directly or indirectly owns shares in the Applicant,

at the option of the Applicant, a guarantee issued by any such person referred to in paragraph (c)(ii) above in favour of the Operating Company and on terms which are no less favourable to the Operating Company than those of any First Demand Parent Company Guarantee, and if any such guarantee is provided, the provisions of this Regasification Code relating to First Demand Parent Company Guarantees and Parent Companies that issue the same will apply with respect to such guarantee and its issuer *mutatis mutandis*; or

- (d) if:
 - (i) the requirements of neither clause 10.1 (a) of chapter III are met by the Applicant nor clause 10.1 (b) of chapter III are met by the Applicant's Parent Company (or were met by the Applicant's Parent Company at the time of submission of the Applicant's Access Request but subsequently ceased to be met prior to such Applicant entering into a Capacity Agreement with the Operating Company in respect of such Access Request); and
 - (ii) clause 10.1 (c) of chapter III does not apply,

an irrevocable and unconditional undertaking from an Approved Issuing Institution to issue a First Demand Guarantee upon a Capacity Agreement being entered into between such Applicant and the Operating Company, such undertaking being in the form set out in Part I of Annex (b). Upon a Capacity Agreement being entered into between the Applicant and the Operating Company, the Applicant shall promptly serve upon the Approved Issuing Institution the notice referred to in such undertaking and shall procure that the Approved Issuing Institution issue such First Demand Guarantee in accordance with the terms of such undertaking.

Courtesy translation, not binding.

III.10.2 First Demand Parent Company Guarantee

10.2.1 Credit downgrade of a User

If an Applicant meets the requirements of clause 10.1 (a) of chapter III and such Applicant becomes a User, or at any time after an Applicant becomes a User such User meets the requirements of clause 10.1 (a) of chapter III, but at any time thereafter such User ceases to meet such requirements, then within ten (10) Business Days after ceasing to satisfy such requirements, the User must provide to the Operating Company a First Demand Parent Company Guarantee (provided that such User's Parent Company meets the requirements of clause 10.1 (b) of chapter III), or failing which a First Demand Guarantee.

10.2.2 Credit upgrade of a User

If a User has provided a First Demand Parent Company Guarantee but at any time during the term of the Capacity Agreement to which such User is a Party such User meets the requirements of clause 10.1 (a) of chapter III, then the Operating Company will promptly release the First Demand Parent Company Guarantee and shall promptly return the original of the latter to the said Parent Company.

10.2.3 Change of control of a User

If a User has provided a First Demand Parent Company Guarantee but at any time during the term of the Capacity Agreement to which such User is a Party such User's Parent Company ceases to be the Parent Company of that User, then the User shall provide to the Operating Company within ten (10) Business Days after the cessation a replacement First Demand Parent Company Guarantee from its new Parent Company (provided that such new Parent Company meets the requirements of clause 10.1 (b) of chapter III), or failing which a First Demand Guarantee. In such event, the Operating Company shall promptly release the previous First Demand Parent Company Guarantee and shall promptly return the original of the latter to the said Parent Company. In the event of any conflict or inconsistency between the provisions of this clause and clause 10.3.1 of chapter III, the provisions of this clause 10.2.3 will prevail.

III.10.3 First Demand Guarantee

10.3.1 Credit downgrade of a User's Parent Company

If a First Demand Parent Company Guarantee is provided to the Operating Company by an Applicant pursuant to clause 10.1 (b) of chapter III and such Applicant becomes a User, or at any time after an Applicant becomes a User a First Demand Parent Company Guarantee is provided to the Operating Company by such User pursuant to clause 10.2.1, 10.2.3 or 10.3.2 (b) of chapter III, but at any time during the term of the Capacity Agreement to which such User is a Party:

- (a) the Parent Company which has given such First Demand Parent Company Guarantee on behalf of the User ceases to meet the requirements of clause 10.1 (b) of chapter III; or
- (b) such First Demand Parent Company Guarantee becomes invalid or unenforceable or

Courtesy translation, not binding.

is due to expire within fifteen (15) Business Days,

then within ten (10) Business Days of any of the events or circumstances described in paragraphs (a) and (b) above, the User must provide to the Operating Company a First Demand Guarantee, and must in addition maintain the First Demand Parent Company Guarantee save where it is wholly invalid or unenforceable or it expires.

10.3.2 Credit upgrade of a User or the User's Parent Company

If a User has provided a First Demand Guarantee but at any time during the term of the Capacity Agreement to which such User is a Party:

- (a) such User meets the requirements of clause 10.1 (a) of chapter III, then the Operating Company shall promptly release the First Demand Guarantee and shall promptly return the original of the latter to the Approved Issuing Institution; or
- (b) the User's Parent Company meets the requirements of clause 10.1 (a) of chapter III but the User does not, then the User shall provide to the Operating Company a First Demand Parent Company Guarantee, and upon doing so the Operating Company shall promptly release the First Demand Guarantee and shall promptly return the original of the latter to the Approved Issuing Institution.

III.10.4 Replacement of and calls on First Demand Guarantee

10.4.1 If a User provides a First Demand Guarantee to the Operating Company pursuant to clause 10.2.1, 10.2.3 or 10.3.1 of chapter III, but at any time during the term of the Capacity Agreement to which such User is a Party:

- (a) any bank or other institution that issued such First Demand Guarantee ceases to be an Approved Issuing Institution; or
- (b) such First Demand Guarantee becomes invalid or unenforceable or is due to expire within fifteen (15) Business Days,

then within ten (10) Business Days of any of the events or circumstances described in paragraphs (a) and (b) above, the User must replace such First Demand Guarantee, by providing to the Operating Company a new First Demand Guarantee for an amount equal to the amount available to be called under the previous First Demand Guarantee immediately prior to the occurrence of the relevant event or circumstance described in paragraph (a) or (b) above.

10.4.2 Where a call is made by the Operating Company on a First Demand Guarantee provided to the Operating Company by a User pursuant to this clause 10 of chapter III, then within ten (10) Business Days of such call being made the User shall procure that:

- (a) such First Demand Guarantee is reinstated, or is replaced by another First Demand Guarantee with an expiry date no earlier than that of the First Demand Guarantee under which the call was made, in either case for the full amount that was available to be called thereunder immediately before the call was made; or

Courtesy translation, not binding.

- (b) such First Demand Guarantee is maintained for the remaining amount available to be called and an additional First Demand Guarantee is provided with an expiry date no earlier than that of the First Demand Guarantee under which the call was made and for an amount which is no less than the amount of the call.

III.10.5 Signing authorities

Each Applicant and each User providing a First Demand Parent Company Guarantee or, as the case may be, a First Demand Guarantee pursuant to this clause 10 will at the same time provide to the Operating Company, or procure the provision of, reasonable evidence that such guarantee has been issued and authorised by the appropriate representative(s) of the Parent Company or Approved Issuing Institution, as the case may be.

III.10.6 Application of clause 10 to Spot Capacity Applicants and Users

Upon request by the relevant Applicant for, or User of, Spot Capacity, the Operating Company has the discretion to waive the requirement that such Applicant or User, as the case may be, provide and maintain financial security pursuant to this clause 10.

III.11 INSURANCE

III.11.1 Operating Company insurance

The Operating Company must have an insurance policy with an Approved Insurance Company in compliance with the requirements of Annex (d) (the "**Terminal Insurance Policy**"), which shall be in effect from the date that it first becomes obliged to provide the Service under a Capacity Agreement until the date it ceases to be obliged to provide the Service under any Capacity Agreement. Upon the request of a User, the Operating Company shall provide reasonable evidence of its compliance with the requirements of this clause 11.1.

III.11.2 User insurance

Each User must have an insurance policy with an Approved Insurance Company in compliance with the requirements of Annex (d) (the "**User Insurance Policy**"), which shall be in effect from the date it is supposed to first receive the Service under the Capacity Agreement to which it is a Party until the expiry date of such Capacity Agreement. Upon the request of the Operating Company, the User shall provide reasonable evidence of its compliance with the requirements of this clause 11.2.

III.12 EXCHANGES OF SUBSCRIBED CAPACITY AND TRANSFERS OF SUBSCRIBED FOUNDATION CAPACITY

III.12.1 Exchanges of Subscribed Capacity

- 12.1.1 Any Capacity User (the "**First Exchanging User**") shall have the right to exchange any part of its Subscribed Capacity with corresponding Subscribed Capacity of another User (the "**Second Exchanging User**") provided that the exchange is performed in accordance with the provisions described below.

Courtesy translation, not binding.

12.1.2 In order to effect an exchange of Subscribed Capacity, both the First Exchanging User and the Second Exchanging User shall send to the Operating Company their respective requests for acceptance of exchange (using the form published by the Operating Company on the Electronic Communication System), indicating:

- (a) the volume of LNG, expressed in cubic metres of LNG with an indicative energy value in MJ;
- (b) the relevant Unloading Slots, with an indication of the specific dates if the exchange relates to Unloading Slots in relation to which the Annual Unloading Schedule or the Three (3) Month Schedule have already been provided by the Operating Company pursuant to clauses 3.2.3 or 3.3.2 of chapter II; and
- (c) the number of berthings;

which they propose to exchange.

12.1.3 The requests for acceptance of exchange shall be received by the Operating Company:

- (a) in the event of exchanges of Subscribed Capacity relating to one or more entire Thermal Years, by the 8th Business Day prior to the beginning of the earliest Thermal Year involved; and
- (b) in the event of exchanges of Subscribed Capacity requested during the course of a Thermal Year, by the 8th Business Day preceding the beginning of the earliest Month involved.

12.1.4 The requests for acceptance of exchange shall be irrevocable and shall contain a statement pursuant to which the First Exchanging User and the Second Exchanging User acknowledge that the exchange shall become effective only upon acceptance by the Operating Company. The Operating Company shall be entitled to reject a request for acceptance of exchange in the following cases:

- (a) either the request of the First Exchanging User or the request of Second Exchanging User is not received by the Operating Company within the deadlines indicated under clause 12.1.3 above;
- (b) the requests for acceptance of exchange of the First Exchanging User and of the Second Exchanging User contain information which are contradictory and/or incomplete;
- (c) the First Exchanging User or Second Exchanging User does not hold the Subscribed Capacity that is the object of the exchange according to their respective Capacity Agreements;
- (d) the First Exchanging User and the Second Exchanging User do not fulfil all the Service Conditions specified under clause 2.3 of chapter III with respect to the portions of Subscribed Capacity being exchanged;
- (e) at the date when the Operating Company receives the requests for acceptance of exchange, the First Exchanging User and/or the Second Exchanging User are in

Courtesy translation, not binding.

breach of any of the provisions of the Regasification Code which would entitle the Operating Company to terminate the relevant Capacity Agreement pursuant to clause 13.1 of chapter III.

12.1.5 Within two Business Day(s) from the expiry of the deadlines indicated under clause 12.1.3 above, the Operating Company shall communicate to the First Exchanging User and the Second Exchanging User:

- (a) the acceptance of the proposed exchange of Subscribed Capacity by returning a copy of the requests duly signed for acceptance by the Operating Company; or, in the event that one or more grounds for rejection set forth in clause 12.1.4 occur,
- (b) the refusal of the request for acceptance of exchange, with an indication of the ground(s) for the non acceptance.

Upon acceptance of a proposed exchange by the Operating Company, the Subscribed Capacity of the First Exchanging User and of the Second Exchanging User under the respective Capacity Agreements and, if applicable, the term of any such Capacity Agreements shall be considered amended in accordance with the information provided by such Parties pursuant to clause 12.1.2.

12.1.6 In case of exchange of Foundation Capacity, the exchange is subject to the criteria provided in article 2, sub-section 3, letter k) of the MAP decree of 11 April 2006.

III.12.2 Transfers of Subscribed Foundation Capacity

12.2.1 A Foundation Capacity User shall have the right to transfer (“*cedere*”) to other persons (“*soggetti*”) any portion of the Foundation Capacity subscribed by it under any Capacity Agreement to which it is a Party provided that:

- (a) the transfer complies with the criteria referred to under article 2, sub-section 3, letter k) of the MAP decree of 11 April 2006;
- (b) the person to which the Subscribed Foundation Capacity is being transferred:
 - (i) provides the information and statements to be included in Access Requests as set forth in clause 2.4.6 of chapter II;
 - (ii) provides the documentation as set forth in clause 2.4.7 of chapter II;
 - (iii) fulfils the Access Conditions as set forth in clause 2.4.5 of chapter II; and
- (c) the Foundation Capacity User provides the Operating Company with a copy of the authorisation by the MSE to transfer the relevant Subscribed Foundation Capacity pursuant to article 8 of the MAP decree of 11 April 2006, it being understood that such authorisation shall not be required in the event of “non systematic spot transfers of Foundation Capacity aimed at optimising the use of Terminal” (“*cessioni di capacità esentata spot di tipo non sistematico finalizzate all’utilizzo ottimale del Terminale*”).

III.13 TERMINATION

III.13.1 Termination by the Operating Company

Any Capacity Agreement may be terminated by written notice from the Operating Company to the relevant User pursuant to article 1456 of the Italian civil code, if any of the following events occur:

- (a) at any time following the payment due date of an invoice the Operating Company notifies such User that payment of such invoice has not been received in full and payment is not received by the Operating Company within ten (10) Business Days after the date that the Operating Company gave such notice, provided that such User has not disputed, postponed or suspended the payment of such invoice pursuant to clause 8.4 of chapter III; or
- (b) any failure by such User, due to any act or omission of such User, to maintain and/or to continue to satisfy one or more of the Service Conditions and such failure to maintain and/or to continue to satisfy one or more of the Service Conditions is not remedied within twenty (20) Business Days from the date on which the User ceases to maintain and/or to continue to satisfy the Service Conditions, provided that:
 - (i) such twenty (20) Business Day period shall run simultaneously with any other remedy period in this Regasification Code (including the remedy periods in clause 10 of chapter III) for a failure to maintain and/or to continue to satisfy any Service Condition; and
 - (ii) this right of termination will not apply to any failure by a User to maintain and/or to continue to satisfy the Service Conditions set out in clause 2.3.1 (h) of chapter III; or
- (c) any of the Representations are not true and accurate as of the date on which the relevant Capacity Agreement is entered into; or
- (d) subject to clause 2.4.3 of chapter III, any breach by such User of the undertaking given in clause 2.4.2 of chapter III.

III.13.2 Withdrawal by the Operating Company

The Operating Company shall have the right to withdraw (*recesso*) from any Capacity Agreement if any of the following events occur, each being a legitimate reason for withdrawal by the Operating Company:

- (a) the User is adjudicated in or otherwise subject to any bankruptcy or insolvency proceedings (be it judicial, administrative or voluntary), except in the case where the Capacity Agreement is taken over by the bankruptcy or insolvency administrator pursuant to applicable law;
- (b) the liquidation, dissolution or winding-up for any reason whatsoever, or closing down of the business activity of the User, or the admission in writing by the User of its inability to pay, or the suspension by the User of the payment of, its debts

Courtesy translation, not binding.

generally as they fall due;

- (c) any judgment or other decision of any competent judicial or administrative authority is issued against the User which has a material and adverse effect on such User's ability to perform its obligations under its Capacity Agreement; or
- (d) the execution and performance of the Capacity Agreement by the User:
 - (i) is in conflict with (I) any Regulation or other applicable law, regulation, administrative or judicial provision or such like which apply to such User; or (II) any other agreement to which such User is a party, or trigger a default under any such agreement; and
 - (ii) such conflict or default has a material and adverse effect on such User's ability to perform its obligations under its Capacity Agreement.

III.13.3 Accrued rights

The termination of, or withdrawal from, any Capacity Agreement (whether pursuant to this Regasification Code or otherwise) shall be without prejudice to the accrued rights and obligations of the Parties in respect of the Service provided prior to, or which is being provided as at, the date of such termination or withdrawal, as the case may be.

III.13.4 Waiver of Italian civil code rights

Without prejudice to any provision of any relevant Capacity Agreement, each User waives its rights under articles 1467, 1660 and 1664 of the Italian civil code.

III.14 LIABILITY

III.14.1 Limitation of liability

- a) Limitation of liability of the Operating Company to the Foundation Capacity User

Without prejudice to clause 6.1.8 of chapter III and clause 3.8.2 of chapter IV, the Operating Company shall not be liable for any costs, losses, damages, claims and/or expenses suffered or incurred by any User of Foundation Capacity or its employees, contractors, agents and/or other third parties acting for it or on its behalf which are caused, directly or indirectly by reason of any failure to perform or performance by the Operating Company or by any employee, contractor, agent or other third party acting for it or on its behalf, of any of the obligations of the Operating Company under any Capacity Agreement, except where and to the extent that any such costs, losses, damages, claims and/or expenses result from wilful misconduct or gross negligence on the part of the Operating Company or its employees, contractors, agents and/or other third parties acting for it or on its behalf. For the avoidance of doubt, it is understood that (i) in no event shall the Transportation Company be considered a "contractor", "agent" or "third party" acting for or on Operating Company's behalf for purposes of this Regasification Code and; (ii) the Operating Company shall not be liable for any costs, losses, damages, claims and/or expenses suffered or incurred by any User of Foundation Capacity or its employees,

Courtesy translation, not binding.

contractors, agents and/or other third parties acting for it or on its behalf which are caused, directly or indirectly by reason of any failure to perform or performance by the Transportation Company or its employees, contractors, agents and/or other third parties acting for it or on its behalf of any of the obligations of the Transportation Company under the Transportation Contract.

b) Limitation of liability of the Operating Company to the Non-Foundation Capacity User and of the Non-Foundation Capacity User to the Operating Company

The liability for any damages arising from or related to the execution or the failure, partial or delayed performance of the obligations under a Non-Foundation Capacity Agreement is expressly limited to gross negligence and wilful misconduct.

c) The User releases and holds the Operating Company harmless of every and any cost, loss, damage, claim and/or expense incurred or sustained in the event of full or partial failed acceptance of Redelivered Gas to the User or to the Transportation System Users indicated by the User as per article 10bis6 of AEEG resolution 167/05 (as amended by AEEG resolution 297/2012/R/Gas).

III.14.2 Payment upon Operating Company termination

14.2.1 If a Capacity Agreement is terminated pursuant to clause 13.1 of chapter III (regardless of whether any of the events specified in clause 13.2 of chapter III have occurred with respect to the User under such Capacity Agreement) then such User must pay, as liquidated damages (*penale*), to the Operating Company, on the effective date of the termination,

(a) an amount equal to the Net Present Value (as at the effective date of the termination) of the aggregate Capacity Charge that would have been payable by such User in the absence of such termination, from such effective date for the remaining term (being until the expiry date specified in such Capacity Agreement), calculated by reference to the remaining aggregate quantities of LNG which were to be Unloaded under such Capacity Agreement throughout such remaining term, plus

(b) an amount equal to the Net Present Value (as at the effective date of termination) of the aggregate Grid Capacity Charge that would have been payable by such User in the absence of such termination, from such effective date for the remaining term (being until the expiry date specified in such Capacity Agreement), calculated by reference to the remaining aggregate quantities of Gas which were to be Redelivered to such User, throughout the remaining term of such Capacity Agreement, net of any portion of such Grid Capacity Charge that is not and will not become due and payable to the Transportation Company following such termination.

14.2.2 The amounts referred to in (a), (b) and (c) above will be calculated on the basis of the *Cqs*, the *CMr* and the Grid Capacity Charge respectively which are applicable to the User who is Party to the terminated Capacity Agreement, as at the effective date of the termination, regardless of the fact that any review or recalculation of the *Cqs*, the *CMr* or the Grid Capacity Charge would or may have taken place at any time during the remaining term of such Capacity Agreement. The Parties acknowledge that the determination of the amounts

Courtesy translation, not binding.

set out in this clause 14.2 has been reasonably made with due regard given to (i) the investment costs borne by the Operating Company for the construction of the Terminal; (ii) the obligations that the Operating Company has assumed under the Transportation Contract; and (iii) the effect of the User's default on the achievement of the Operating Company's economic interests. Pursuant to and for the purposes of article 1382 of the Italian civil code, the payment of such amount by the User will be the only remedy that the Operating Company has against such User in the case of termination pursuant to clause 13.1 of chapter III, except for the Operating Company's rights under clauses 4.1, 5.1.7, 6.1.4 (f), 6.1.4 (i), 9.2, 14.3 and 14.5 of chapter III and clause 3.8.2 (b) of chapter IV.

14.2.3 Should the Subscribed Capacity which has become available as a result of the termination of a Capacity Agreement pursuant to clause 13.1 of chapter III and in relation to which the relevant User has made payments to the Operating Company pursuant to letter (a) of clause 14.2.1 above be subsequently reallocated to another User in whole or in part, the Operating Company shall reimburse the original User the discounted amounts of the Capacity Charge that such User has paid the Operating Company with respect to such reallocated Foundation Capacity and/or Non-Foundation Capacity pursuant to letter (a) of clause 14.2.1 above as soon as the Operating Company shall reallocate Foundation Capacity and/or Non Foundation Capacity to the new User.

14.2.4 Should the transportation capacity which has become available as a result of the termination of a Capacity Agreement pursuant to clause 13.1 of chapter III and in relation to which the relevant User has made a payment to the Operating Company pursuant to letter (b) of clause 14.2.1 above be subsequently reallocated to another User in whole or in part, the Operating Company shall reimburse the original User the discounted amounts of the Grid Capacity Charge that such User has paid the Operating Company with respect to such reallocated transportation capacity as soon as the Operating Company has reallocated such transportation capacity to another User.

III.14.3 User indemnity for Damaging Events

- (a) Each User must indemnify and hold the Operating Company harmless in respect of any costs, losses, damages, claims and/or expenses (including legal fees) of any kind suffered or incurred by the Operating Company as a result of any loss of, damage to or failure of all or part of the Terminal which is caused by the acts or omissions of:
- (i) such User;
 - (ii) any Shipowner acting for or on behalf of such User or for or on behalf of the person specified in paragraph (iv) below;
 - (iii) any member of the LNG Tanker crew acting for or on behalf of such Shipowner and/or User;
 - (iv) any person supplying LNG to or on behalf of such User;
 - (v) any employees, contractors, agents and/or other third parties acting for or on behalf of any person specified in paragraphs (i) to (iv) inclusive above,

(each instance of loss of, damage to or failure of all or part of the Terminal which is

Courtesy translation, not binding.

caused by the acts or omissions of any of the persons identified in paragraphs (i) to (v) inclusive above being a "**Damaging Event**" and a User that is responsible for such Damaging Event, by way of the above indemnity, being a "**Damaging User**").

- (b) In addition to its obligations under clause 14.3 (a) of chapter III, and without prejudice to the provisions of clauses 6.1.4 (f) and 6.1.4 (i) of chapter III, each Damaging User must indemnify and hold the Operating Company harmless in respect of any loss of or reduction in any Capacity Charge which would otherwise have been payable to the Operating Company by any User, including the Capacity Charge which otherwise would have been payable by the Damaging User, had such Damaging Event not occurred. For these purposes, until the effects of the Damaging Event are cured and the functioning of the Terminal is returned to the level that it was at immediately prior to the occurrence of the Damaging Event, the Capacity Charge will be calculated as if such Damaging Event had not occurred.
- (c) Any Damaging User that is also a Shipowner hereby expressly waives any right to the Shipowner's limited liability as provided for under articles 7 and 275 of the Italian navigation code or any other applicable provisions of law.

III.14.4 No actions amongst Users

Each User waives any right to take action against any other User or against any employees, contractors, agents or other third parties (including any Shipowner) acting for or on behalf of such other User who, by their acts or omissions, directly or indirectly, cause any reduction or suspension in the performance of the Service, except where any such reduction or suspension has arisen as a result of gross negligence or wilful misconduct on the part of such other User or of any of its employees, contractors, agents or other such third parties (including any Shipowner acting for or on behalf of such other User).

III.14.5 Environmental indemnity from Users

Except in case of gross negligence or willful misconduct of the Operating Company, Users of Foundation Capacity and/or, as appropriate, the User of Non-Foundation Capacity, but for the latter only in case of wilful misconduct and/or gross negligence, must indemnify and hold the Operating Company harmless in respect of any costs, losses, damages, claims and/or expenses of any kind which may be suffered or incurred by the Operating Company which arise as a result of any (a) claim against the Operating Company in respect of a breach by such User of any Regulation relating to the Environment or to health and safety in the work place, (b) claim by any person in respect of any loss or liability incurred by that person as a result of any breach by such User of any Regulation relating to the Environment or to health and safety in the work place, and (c) contamination of the Environment caused by any act or omission of such User. References in this clause 14.5 to a User shall be deemed to include the persons specified in clauses 14.3 (a) from (ii) to (v) inclusive of chapter III.

III.15 COMPLAINTS

III.15.1 Inspections of the Service

Upon obtaining the Operating Company's prior written consent, which cannot be unreasonably withheld or delayed, a reasonable number of User's designated

Courtesy translation, not binding.

representatives may from time to time inspect the operations at the Terminal, as long as such inspection occurs from 9:00 hours to 18:00 hours on any Business Day. Any such inspection shall be at the sole risk, cost and expense of the User, and shall comply with all applicable provisions of the Terminal Regulations. The User's right to inspect and examine the Terminal shall be limited to verifying the performance of the Service by the Operating Company and the compliance by the Operating Company with its obligations under the applicable Capacity Agreement.

III.15.2 Complaints

Subject to clause 8.6 of chapter III, any complaint about the performance of the Service must be notified by a User to the Operating Company within thirty (30) Business Days after the earlier of (a) the date on which the User first had knowledge of the occurrence of the event that has given rise to the complaint and (b) the date on which the User should have had knowledge (acting diligently) of the occurrence of such event.

III.15.3 Supporting documentation for complaints

The User must enclose with any notice sent to the Operating Company pursuant to clause 15.2 of chapter III all documentation which is reasonably necessary to establish the soundness of its claims.

III.15.4 Restriction on bringing complaints

No User shall be entitled to file complaints or bring any proceedings concerning performance of the Service in respect of any LNG (or resultant Gas) once the corresponding resultant Gas has been accepted by the Transportation Company in accordance with the provisions of clause 6.1.2 of chapter III.

III.16 DOMICILE AND NOTICES

III.16.1 Service of notices

Except as otherwise specified herein or otherwise agreed in writing between the Parties, any communication or notice relating to the Capacity Agreement shall be:

- (a) sent by letter with a return receipt (with a copy of such letter sent by fax and/or email), or, to the extent allowed under Italian law and adopted by the Operating Company, by certified email (*posta elettronica certificata*), to the following addresses:
 - (i) for the Operating Company, to the contact details specified and published on its Electronic Communication System, provided that the Operating Company shall notify all Users of any modification in this respect;
 - (ii) for a User, to the contact details specified in the relevant Capacity Agreement, provided that the User shall notify the Operating Company of any modification in this respect; and
- (b) deemed to have been received upon delivery of such letter or certified email at the

Courtesy translation, not binding.

other Party's address as set forth in paragraph (a) above.

III.16.2 Domicile for notice purposes

The respective addresses referred to in clause 16.1 of chapter III are the Operating Company's and each respective User's domicile for all notice purposes, including the service of process, in relation to the Capacity Agreement between such Parties.

III.17 WAIVER

The failure or delay, even over time, in any of the Parties exercising any rights or remedies to which the same is entitled under any Capacity Agreement shall not be considered as a waiver of such rights or remedies and shall not be deemed as an implicit amendment to the terms and conditions of the Capacity Agreement between such Parties.

III.18 CONFIDENTIALITY

III.18.1 No disclosure of confidential information

All information regarding the business of any Party that is given in any form in accordance with, pursuant to, or in relation to a Capacity Agreement shall be confidential and must not be disclosed or used by any other Party or by its employees, contractors, agents and/or other third persons acting for or on behalf of such other Party, provided that any such information that has been provided by or relates to a User may be used by the Operating Company, its employees, contractors, agents and/or other third parties acting for or on behalf of the Operating Company to the extent that it is required for the proper performance of the Service. Any such information must not be disclosed to any person without the prior written consent of the Party to which such information relates, and any such permitted disclosure shall be subject to acceptance by the person to whom the information is to be disclosed of similar confidentiality obligations as are set out in this clause 18.

III.18.2 Liability for disclosure of confidential information

Each Party shall be liable for any loss or damage to the other Party in the event of any disclosure or transfer of confidential information of the type described in clause 18.1 of chapter III which is communicated by the first Party or by its employees, contractors, agents and/or other third persons acting for it or on its behalf without the prior consent of the latter Party.

III.18.3 Exceptions to confidentiality

Notwithstanding clauses 18.1 and 18.2 of chapter III, a Party (the "**Disclosing Party**") may, without the prior consent of the other Party, disclose to any person confidential information under clause 18.1 of chapter III where:

- (a) it is generally known to the public when it is disclosed or it has become generally known to the public other than by reason of any default, omission or negligence by the Disclosing Party;

Courtesy translation, not binding.

- (b) the Disclosing Party has become aware of such information through any third person and the Disclosing Party was not aware of any breach by such third person of any confidentiality obligation with respect to the other Party;
- (c) such disclosure is required by any Competent Authority or by any other competent institutional body, either national or international, or is otherwise required by law or by any regulation (including any rules of any stock exchange or other regulated market);
- (d) subject to the compliance with the confidentiality of commercially sensitive information as provided in the Regulation, the disclosure is made to the Disclosing Party's shareholders, Affiliates, affiliates of its shareholders and such of their officers, directors and employees to whom communication is reasonably necessary on a need to know basis for the purposes of the relevant Capacity Agreement, in each case provided that the shareholder, Affiliate or affiliate of such shareholder, on behalf of itself and its officers, directors and employees undertakes to maintain the confidentiality of such confidential information on substantially similar terms as those set out in this clause 18;
- (e) the disclosure is made to persons participating in the implementation of the arrangements contemplated by the relevant Capacity Agreement, to whom such communication is reasonably necessary on a need to know basis for the purposes of such Capacity Agreement, including legal counsel, accountants, other professional, business or technical consultants and advisers, underwriters or lenders, and any other such participating person, provided that the receiving persons undertake to maintain the confidentiality of such confidential information on substantially similar terms as those set out in this clause 18; and/or
- (f) the disclosure is made to any court, expert, or arbitrator to which any dispute between the Parties has been referred.

III.18.4 Duration of confidentiality obligations

As between the Parties to a Capacity Agreement, the confidentiality obligations set out in this clause 18 shall remain in force for a period of three (3) years from the earlier of: (i) the expiration date of such Capacity Agreement; (ii) the date on which such Capacity Agreement is terminated or a Party withdraws therefrom in accordance with its terms (*risolto o altrimenti sciolto o divenuto inefficace per qualsiasi causa, ivi incluso il recesso di una delle Parti*), notwithstanding that a subsequent Capacity Agreement is not entered into between the Parties.

III.18.5 Compliance with confidentiality laws

The Parties hereby undertake that in the performance of their respective obligations under any Capacity Agreement to which they are a Party, they will each comply and procure that their employees, contractors, agents and/or any other third persons acting for or on behalf of either such Party for any reason, will comply with all Regulations and any other applicable laws, regulations, administrative and judicial provisions and the like relating to confidentiality. Each Party shall be liable to the other Party for any loss or damage that may be caused by any failure to comply with this clause 18.5.

III.18.6 Statement of information under the applicable data protection Regulations

Pursuant to article 13 of legislative decree no. 196 of 30 June 2003, with reference to the personal data of the Parties (the "**Parties' Data**") acquired during negotiations, execution or performance of the relevant Capacity Agreement, each Party represents to the other Party that:

- (a) the Parties' Data shall be processed, also with the help of electronic or automated means, for purposes which relate to the performance of such Capacity Agreement, or for the performance of the obligations set out in applicable Regulations;
- (b) provision of the Parties' Data is necessary for the performance of such Capacity Agreement, and refusal to provide such Parties' Data could cause difficulties in the performance thereof;
- (c) the Parties' Data shall be disclosed only to the consultants of the Parties or to parties appointed to process the relevant data, for the purposes set out in paragraph (a) above, and shall not be otherwise disclosed or divulged to third parties;
- (d) in relation to the processing of the Parties' Data, each Party may exercise the rights under article 7 of legislative decree no. 196 of 30 June 2003; and
- (e) each Party will act as data controller with regard to the processing of the Parties' Data relating to the other Party.

III.19 ENFORCEMENT COSTS

A Party shall, within thirty (30) Business Days after a demand by the other Party which includes adequate supporting documentation, pay to such other Party the amount of all reasonable costs and expenses (including the reasonable fees and expenses of its legal and financial advisors) incurred by such other Party in connection with the enforcement of, or the preservation of any of its rights under, their Capacity Agreement, where the Party receiving such demand is in breach of such Capacity Agreement.

III.20 WAIVER OF IMMUNITY

Each Party irrevocably and unconditionally:

- (a) agrees that should a Party bring any legal proceedings (whether pursuant to clause 4 of chapter I or otherwise) against the other Party or its assets in connection with a Capacity Agreement, no immunity (sovereign or otherwise) from such legal proceedings or the result of such legal proceedings, shall be claimed under the laws of Italy or any other state or jurisdiction, by or on behalf of such other Party or with respect to any of its assets;
- (b) waives any such right of immunity that each Party or any of its assets has or may acquire under the laws of Italy or any other state or international organisation; and
- (c) consents generally to the giving of any relief or the issue of any process in

Courtesy translation, not binding.

connection with such legal proceedings, including the making, enforcement or execution against any property whatsoever (irrespective of its use or intended use) of any order, award, determination or judgment that may be made or given in such proceedings under the laws of Italy or any other state or international organisation.

CHAPTER IV

ACCESS OF LNG TANKERS TO THE TERMINAL

IV.1 LNG TANKERS

IV.1.1 LNG Tankers requirements

All LNG Tankers used by or on behalf of a User within the scope of the Capacity Agreement to which such User is a Party shall be: (i) subject to acceptance by the Operating Company pursuant to the procedure set out in clauses 1.2 through 1.4 of chapter IV; and (ii) operated in compliance with the Terminal Regulations, Maritime Regulations, the Cargo Handling Manual and the LNG Tanker Vetting Procedure.

IV.1.2 Acceptance of LNG Tankers

Each User must notify the Operating Company as soon as reasonably practicable the names of each LNG Tanker that will be used for the transportation to and Unloading of LNG at the Terminal in accordance with the Capacity Agreement to which such User is a Party.

If any User wishes to use new-built LNG Tankers about which all relevant operational and procedural information is not available to the Operating Company, then the Operating Company and such User shall meet in order to define a procedure for the acceptance of such LNG Tankers.

After being notified of the names of any new-built or existing LNG Tanker that a User wishes to use for the transportation and Unloading of LNG, the Operating Company shall apply the LNG Tanker Vetting Procedure and shall send to such User a questionnaire that the User shall return duly completed to the Operating Company as soon as reasonably practicable.

On the basis of the information received, the Operating Company shall be entitled to request an inspection of any such LNG Tanker, the timing and conditions of any such inspection to be agreed between the Parties. Each Party shall bear its own costs and expenses relating to any such inspection.

The Operating Company must notify the relevant User of the acceptance or rejection of a proposed LNG Tanker within five (5) Business Days after receipt from such User of the duly completed questionnaire in respect of such LNG Tanker or after completion of the inspection provided for under this clause 1.2, whichever is the later.

In the case of acceptance, the Operating Company will send to the User two (2) copies of each of the following documents:

- (a) the Maritime Regulations;
- (b) the Terminal Regulations; and

Courtesy translation, not binding.

- (c) the Cargo Handling Manual.

An electronic version of the documents above shall be available on the Electronic Communication System.

Operating Company shall keep on the Electronic Communication System a list of LNG Tankers that have been determined to be technically compatible for Unloading at the Terminal and shall promptly update such list in the event of any addition of new LNG Tanker or of any removal of an LNG Tanker from such list.

IV.1.3 Rejection of LNG Tankers

The Operating Company shall have the right to reject an LNG Tanker:

- (a) where the proposed LNG Tanker or its master and/or crew does not comply with the standards contained in the LNG Tanker Vetting Procedure;
- (b) where the Operating Company has previously accepted such LNG Tanker and such LNG Tanker or its master and/or crew no longer complies with the standards contained in the LNG Tanker Vetting Procedure;
- (c) where the User that uses such LNG Tanker, or on behalf of which such LNG Tanker is used, or, as the case may be, such LNG Tanker or its master and/or crew have ceased to maintain and/or to continue to satisfy any of the requirements set out in clauses 2.3 (e), 2.3 (f) and 2.3 (g) of chapter III; and/or
- (d) where such User fails to make, or procure that any third person makes, the necessary modifications pursuant to and in accordance with clause 1.4.2 of chapter IV.

Any rejection of an LNG Tanker must be duly justified in writing by the Operating Company.

IV.1.4 Modifications to LNG Tankers

1.4.1 User's obligation to make necessary modifications

- (a) Each User must notify the Operating Company of any subsequent modification to or damage suffered by any LNG Tanker used by or on behalf of it for the purposes of the Capacity Agreement to which such User is a Party, that may affect the safe operation of the Terminal and/or the compatibility of such LNG Tanker with the Terminal.

Upon receipt of any such notice, the Operating Company and the Maritime Authorities must confirm whether such LNG Tanker (i) may affect the safe operation of the Terminal, and (ii) continues to be compatible with the Terminal. The Operating Company and/or the Maritime Authorities may request a new inspection of such LNG Tanker, on the basis set out in clause 1.2 of chapter IV.

If the Operating Company and/or the Maritime Authorities confirm that such LNG

Courtesy translation, not binding.

Tanker (i) may affect the safe operation of the Terminal, and/or (ii) is not compatible with the Terminal, then the relevant User shall:

- (aa) procure that all necessary modification or alteration works be carried out to such LNG Tanker to the satisfaction of the Operating Company and, as between the Parties to a Capacity Agreement, the costs and expenses arising from such works will be borne by the User that uses such LNG Tanker, or on behalf of which such LNG Tanker is used; and/or
 - (bb) by notice to the Operating Company, substitute such LNG Tanker, either permanently or until the works described in paragraph (aa) above are complete, with another LNG Tanker which will not affect the safe operation of and which is compatible with the Terminal, and the provisions of clauses 1.1 to 1.4 of chapter IV will apply with respect to such other LNG Tanker.
- (b) If, at any time as a result of any change in Regulation or other applicable law, regulation, administrative or judicial provision or such like, or the coming into effect of a new Regulation or other applicable law, regulation, administrative or judicial provision or such like, any LNG Tanker ceases to be compatible with the Terminal (including where any LNG Tanker ceases to be compatible due to a change in Regulation or the coming into effect of a new Regulation which in either case requires works to be carried out to the Terminal), and it becomes necessary to modify or alter any LNG Tanker so as to make such LNG Tanker compatible with the Terminal, then the relevant User shall promptly comply with paragraphs (aa) and (bb) above with respect to such LNG Tanker.
- (c) The Operating Company may require any User to make modifications to an LNG Tanker during the term of that User's Capacity Agreement only under the circumstances specified in paragraphs (a) and (b) above.

1.4.2 Failure to make necessary modifications

The Operating Company shall be entitled to reject any LNG Tanker if such LNG Tanker may affect the safe operation of the Terminal and/or such LNG Tanker ceases to be compatible with the Terminal for any of the reasons specified in paragraphs (a) and/or (b) of clause 1.4.1 of chapter IV, and the relevant User does not promptly:

- (a) procure that the necessary modification or alteration works are carried out to such LNG Tanker to the satisfaction of the Operating Company; and/or
- (b) substitute such LNG Tanker, either permanently or until the works described in paragraph (a) above are complete, with another LNG Tanker which will not affect the safe operation of and which is compatible with the Terminal, and which the Operating Company has accepted pursuant to clause 1.2 of chapter IV.

IV.2 NOTICES

IV.2.1 Departure notice

Until the User tenders the Departure Notice as specified below, the ETA will

Courtesy translation, not binding.

conventionally be deemed to be (i) twenty-four (24) hours after the start of the Scheduled Arrival Range for LNG Tankers that load LNG at a port located outside the Mediterranean Sea, and (ii) twelve (12) hours after the start of the Scheduled Arrival Range for LNG Tankers that load LNG at a port located within the Mediterranean Sea.

Upon departure from the loading port, the User must give, or cause the master of the LNG Tanker which is transporting LNG to the Terminal for or on behalf of such User to give, to the Operating Company by way of fax, or e-mail a notice containing the following information:

- (a) the loading port of the LNG Tanker;
- (b) the name of the LNG Tanker;
- (c) the time and date when LNG loading was completed;
- (d) the quantity of LNG loaded at the loading port and the portion of such quantity to be Unloaded at the Terminal, if less than the full quantity; and
- (e) the ETA of the LNG Tanker at the Terminal.

As soon as reasonably possible after the departure from the loading port, the User must notify the Operating Company of the quality of LNG loaded, pursuant to clause 5.1.1 of chapter III.

The User must give, or cause the master of the LNG Tanker to give, to the Operating Company by way of fax, or e-mail, notice of any change in such ETA which is equal to or greater than twelve (12) hours, as soon as reasonably practicable.

IV.2.2 Forty-eight (48) hours advance notice

The User must give, or cause the master of the LNG Tanker to give, to the Operating Company by way of fax, or e-mail, notice of its then latest ETA that shall be sent forty eight (48) hours prior to such ETA, if applicable given the voyage time of the LNG Tanker.

The User must promptly give, or cause the master of the LNG Tanker to promptly give, to the Operating Company by way of fax, or e-mail, notice of any change in such ETA which is equal to or greater than six (6) hours.

IV.2.3 Twenty-four (24) hours advance notice

The User must give, or cause the master of the LNG Tanker to give, to the Operating Company by way of fax, or e-mail, notice of its then latest ETA that shall be sent twenty four (24) hours prior to such ETA.

The User must promptly give, or cause the master of the LNG Tanker to promptly give, to the Operating Company by way of fax, or email, notice of any change in such ETA which is equal to or greater than three (3) hours.

Courtesy translation, not binding.

IV.2.4 Arrival notice

The User must give, or cause the master of the LNG Tanker to give, to the Operating Company by way of fax, or e-mail, notice of its then latest ETA that shall be sent five (5) hours prior to such ETA.

IV.2.5 Notice of Readiness

Upon arrival of the LNG Tanker at the Pilot Boarding Station, the master of the LNG Tanker or his agent must give notice to the Operating Company that such LNG Tanker is ready to berth at the Terminal and to Unload ("**Notice of Readiness**"). Such Notice of Readiness shall be tendered by way of fax and shall:

- (a) be signed by the master of the LNG Tanker;
- (b) state the time and date when it was given; and
- (c) be addressed to the person designated by the Operating Company.

Prior to tendering a Notice of Readiness to the Operating Company, the master of the LNG Tanker must verify that the LNG Tanker has reached the Pilot Boarding Station, that the LNG Tanker is ready for all purposes for berthing and for Unloading, and that all necessary authorisations, licences and/or permits relating to port marine services have been granted and are held pursuant to and for the purposes of article 101 and subsequent articles of the Italian Navigation Code.

The Notice of Readiness shall be received and accepted by the Operating Company at any time on any Day, provided that before accepting such Notice of Readiness the Operating Company may verify that all conditions to tendering such Notice of Readiness, which are set out in the Regasification Code, have been met, including those described in the paragraph immediately above. Subject to the provisions of clause 3 of chapter IV, the Operating Company must upon receipt of such Notice of Readiness give the LNG Tanker instructions for berthing at the Terminal.

In the event the LNG Tanker has tendered the Notice of Readiness without satisfying the conditions to tender such Notice of Readiness, then the Operating Company shall issue a notice of protest invalidating such Notice of Readiness.

The LNG Tanker shall berth, Unload and depart as safely and expeditiously as reasonably possible in co-operation with the Operating Company.

The Operating Company must take all due measures, in accordance with prudent and safe practices, to allow Unloading of the LNG Tanker as safely and expeditiously as reasonably possible.

IV.3 ARRIVAL AND UNLOADING OF LNG TANKERS AT THE TERMINAL

IV.3.1 Procedures for LNG Tankers

3.1.1 Movements of LNG Tankers in the Terminal docking area

Courtesy translation, not binding.

Each User must enter into, or, at its own expense, procure to be entered into by third persons, all necessary agreements for the operation and the movement of LNG Tankers between the Pilot Boarding Station and the Terminal, including those for tugs, pilotage, mooring, line handling, light dues and any other required services necessary for berthing, Unloading, and unmooring of LNG Tankers. Such operations must at all times be carried out in a manner which is consistent with the Terminal Regulations and the Maritime Regulations.

3.1.2 Berthing, Unloading and unmooring operations

The berthing, Unloading and unmooring operations in respect of LNG Tankers shall be governed by:

- (a) the Maritime Regulations;
- (b) the Terminal Regulations; and
- (c) the Cargo Handling Manual.

User shall arrange that an adequate plan consistent with IMO Ship/Shore Safety Checklist for discharging LNG has been agreed in writing with the Operating Company before the commencement of Unloading operations.

IV.3.2 On-Time Arrival

If an LNG Tanker tenders pursuant to clause 2.5 of chapter IV its Notice of Readiness within the Scheduled Arrival Range, the Operating Company must immediately accept the LNG Tanker for Unloading, taking into account all applicable Regulations then in force and save as otherwise provided in this Regasification Code.

In the circumstances described in this clause 3.2, Laytime in respect of such LNG Tanker shall start:

- (a) six (6) hours after the Notice of Readiness has been tendered pursuant to clause 2.5 of chapter IV; or
- (b) when the LNG Tanker is all fast at berth,

whichever is the earlier.

IV.3.3 Early Arrival

If an LNG Tanker tenders pursuant to clause 2.5 of chapter IV its Notice of Readiness before the Scheduled Arrival Range, the Operating Company shall not be bound to accept the LNG Tanker for Unloading before such Scheduled Arrival Range, except where:

- (a) the Terminal berth is available for berthing; for this purpose the Operating Company shall use all reasonable endeavours to make the berth available for berthing;

Courtesy translation, not binding.

- (b) there is sufficient available capacity in the storage tanks of the Terminal; for this purpose, the Operating Company shall use all reasonable endeavours to make such Storage capacity available;
- (c) such Unloading will not prejudice the safe operation of the Terminal or the Unloading of other LNG Tankers that are scheduled for Unloading at the Terminal; and
- (d) such Unloading will not adversely impact the Redelivery of Gas to other Users.

In the circumstances described in this clause 3.3, Laytime in respect of such LNG Tanker shall start:

- (i) at 18:00 hours on the first Day of the Scheduled Arrival Range, as provided in the relevant User's Three (3) Month Schedule; or
- (ii) when the LNG Tanker is all fast at berth,

whichever is the earlier.

IV.3.4 Late Arrival

If an LNG Tanker tenders pursuant to clause 2.5 of chapter IV its Notice of Readiness after the Scheduled Arrival Range, the Operating Company shall not be bound to accept the LNG Tanker for Unloading, except where:

- (a) the Terminal berth is available for berthing; for this purpose the Operating Company will use all reasonable endeavours, to make the berth available for berthing;
- (b) there is sufficient available capacity in the storage tanks of the Terminal; for this purpose, the Operating Company will use all reasonable endeavours to make such Storage capacity available;
- (c) such Unloading will not prejudice the safe operation of the Terminal or the Unloading of other LNG Tankers that are scheduled for Unloading at the Terminal; and
- (d) such Unloading will not adversely impact the Redelivery of Gas to other Users.

In the circumstances described in this clause 3.4, Laytime in respect of such LNG Tanker shall start when the LNG Tanker is all fast at berth.

IV.3.5 Delays

If two or more LNG Tankers have tendered valid Notices of Readiness pursuant to clause 2.5 of chapter IV and their respective Unloading Slots have not been cancelled pursuant to clause 3.7.1 of chapter II, but cannot berth at the Terminal, then the following procedure shall apply:

- (a) any LNG Tankers that have tendered their Notices of Readiness within or before

Courtesy translation, not binding.

their respective Scheduled Arrival Ranges will be berthed and Unloaded in the same sequence of their respective Scheduled Arrival Ranges;

- (b) LNG Tankers that have tendered their Notices of Readiness after their respective Scheduled Arrival Range shall:
 - (i) have lower access priority to the Terminal than LNG Tankers referred to in paragraph (a) above; and
 - (ii) be berthed and Unloaded in the order in which such Notices of Readiness were tendered, provided that the berthing and Unloading of any such LNG Tanker satisfies all of the conditions set forth in clause 3.4 of chapter IV; and
- (c) the Operating Company and the Users will each use all reasonable endeavours to accelerate the berthing, Unloading and unmooring of such LNG Tankers.

IV.3.6 Re-Assignment of Berth

If any LNG Tanker is delayed in berthing and/or commencement of Unloading for any reason attributable to the User, to the LNG Tanker or to its master, crew, owner or operator and if, as a result thereof, the commencement of berthing and/or Unloading is delayed beyond thirty (30) hours after the Notice of Readiness has been tendered, the Operating Company shall be entitled to allocate the berth to another LNG Tanker which is ready for Unloading.

In such event, for the purposes of clause 3.8 of chapter IV, the Operating Company shall not be liable to pay Demurrage to the User whose LNG Tanker caused the delay for the time during which such other LNG Tanker occupies the berth.

IV.3.7 Completion of Unloading

Upon the Completion of Unloading, the LNG Tanker must leave the berth as soon as it is safely able to do so in compliance with the Maritime Regulations and Terminal Regulations then in force, unless otherwise expressly permitted in writing by the Operating Company.

In any case, the LNG Tanker must leave the berth at any time on the Operating Company's request for safety reasons.

IV.3.8 Laytime and Demurrage

3.8.1 Laytime

Laytime shall be twenty-four (24) consecutive hours. Laytime shall be extended, on a case by case basis, by any period of delay due to any of the following reasons which are beyond the Operating Company's reasonable control:

- (a) reasons attributable to the User, to the LNG Tanker or to its master, crew, owner or operator (including any time spent loading stores, refuelling, changing crew, repairing and maintaining the LNG Tanker);

Courtesy translation, not binding.

- (b) reasons attributable to the Transportation Company not caused by the Operating Company;
- (c) reasons attributable to the Port Authority;
- (d) the User, the LNG Tanker, its master, crew, owner or operator waiting for port, towage, pilotage or berthing services;
- (e) a Force Majeure Event; or
- (f) adverse weather and/or sea conditions that prevent the LNG Tanker from berthing, Unloading or unmooring.

3.8.2 Demurrage

- (a) If Completion of Unloading of an LNG Tanker occurs after the expiry of the Laytime for such LNG Tanker, then the Operating Company must pay to the User for whom or on whose behalf such LNG Tanker was Unloading, demurrage for each hour or fraction thereof by which such Completion of Unloading occurs after the expiry of such Laytime, at a rate per hour which is equal to the following:
 - (i) 1,750 (one thousand, seven hundred and fifty) USD / hour for LNG Tankers with a gross loading capacity of up to (but excluding) 105,000 cubic metres; and
 - (ii) 3,250 (three thousand, two hundred and fifty) USD / hour for LNG Tankers with a gross loading capacity equal to or greater than 105,000 cubic metres,

("Demurrage").

In such case User shall invoice Operating Company for the amount of Demurrage payable along with relevant documents and calculations in support of such amount. Such Demurrage payments shall become due twenty (20) Days after the date on which Operating Company receives the invoice.

Pursuant to and for the purposes of the Regasification Code the payment of Demurrage shall be the sole compensation payable by the Operating Company to a User if the Unloading of an LNG Tanker which is delivering LNG for or on behalf of such User is not completed within the Laytime for such LNG Tanker.

Notwithstanding the foregoing, in the event that, after Laytime has commenced, Operating Company cancels the corresponding Unloading Slot pursuant to clause 3.7.1 of chapter II, Completion of Unloading, solely for the purpose of determining Demurrage, shall be deemed to have occurred forty-eight (48) hours after such notice has been provided.

- (b) Without prejudice to clause 14.3 of chapter III, if the Operating Company incurs any Demurrage to any User for reasons attributable to another User ("**Liabe User**") or to the LNG Tanker which delivers LNG for or on behalf of the Liabe User, then the Liabe User must pay to the Operating Company an amount equal to the Demurrage so incurred. Any such Demurrage owed by the Liabe User shall be invoiced pursuant to clause 8.1 of

chapter III.

IV.3.9 Excess Boil-off

If an LNG Tanker is delayed in berthing and/or in commencement of Unloading for reasons other than a Force Majeure Event or the fault of the User or the LNG Tanker or the LNG Tanker's master, crew, owner or operator, or reasons attributable to the Maritime Authorities and if, as a result thereof, the commencement of Unloading is delayed beyond thirty (30) hours after Notice of Readiness has been given, then, provided the LNG Tanker issues the Notice of Readiness within its Scheduled Arrival Range, (i) no Capacity Charge and, (ii) in the event that the such delay is the result of a grossly negligent or wilful act or omission of the Operating Company or its employees, contractors, agents and/or other third parties acting for it or on its behalf (it being understood that in no event shall the Transportation Company be considered a "contractor" or a "third party" acting for, or on behalf of, the Operating Company), no Grid Capacity Charge shall be due in respect of the corresponding Excess Boil-off.

Excess Boil-off shall be calculated by taking the difference between the actual quantity on board the LNG Tanker thirty (30) hours after tendering the Notice of Readiness and the actual quantity on board such LNG Tanker immediately prior to commencement of Unloading.

If it appears that the commencement of Unloading shall be delayed beyond thirty (30) hours after Notice of Readiness has been given, the User shall notify the Operating Company at least six (6) hours prior to such time that it intends to measure the quantity of LNG in the LNG Tanker's tanks, and the Operating Company shall have the right to have its representative present to witness the measurement; provided, however, that should the Operating Company be unable to send a representative on a timely basis, the User shall proceed to make the measurement and shall notify the Operating Company of the results of the measurement promptly upon completion thereof.

CHAPTER V

MANAGEMENT OF SERVICE EMERGENCIES

V.1 INTRODUCTION

The Operating Company has adopted emergency operating procedures, entitled “Emergency Response Procedures”, in order to deal with emergency situations (including fire, leakage of liquids or flammable gas) which may interfere with the operation of the Terminal, and which may jeopardize the safety of persons, property, or the environment. The Emergency Response Procedures take into account the fact that emergencies vary by level of seriousness.

The Emergency Response Procedures, which defines the actions that the personnel of the Operating Company are to take during emergency situations, is in accordance with the provisions set out in the legislative decree 17 August 1999, no. 334 (“Application of the directives 96/82/EC regarding the control of dangers for accidents connected with certain dangerous substances”) and in accordance with legislative decree 9 April 2008, no. 81 (“Implementation of article 1 of law 3 August 2007, n. 123, concerning the safeguarding of the safety and health conditions in the workplace”). This chapter summarises the content of the Emergency Response Procedures.

V.2 SERVICE EMERGENCIES

V.2.1 Types of emergency

The types of emergency referred to in this paragraph are caused by the accidental leakage of Gas or LNG which results in the inability to operate the Terminal and/or perform the Service in a safe manner.

V.2.2 Levels of emergency

There are two types of emergency alarms on the Terminal:

- 1st level “General Facility Alarm” – Terminal personnel attend their designated muster stations;
- 2nd level “Prepare to Abandon Facility Alarm” – Terminal personnel attend their lifeboat stations;

The 1st level of emergency represents the lowest level and, depending on the initiating event and location, may result in a process shutdown.

The 2nd level of emergency constitutes the highest emergency level and would be associated with total shutdown of the process systems.

Each of the above emergency alarms can be initiated by activation of various detection devices which register presence of hydrocarbons (i.e., Gas/LNG). The hydrocarbon release may lead to a lower hydrocarbon/air mixture, resulting in a potentially explosive mixture

Courtesy translation, not binding.

being achieved.

V.2.3 Objectives of intervention

The Emergency Response Procedures, both tactical and strategic, address credible emergency scenarios. These procedures provide guidance to staff present on the Terminal and onshore with regard to appropriate response measures to be taken for the type of emergency.

The objectives of the Emergency Response Procedures are the following:

- provide both general and specific instructions (depending on the kind of task performed at the facilities) in order to effectively deal with the emergency;
- provide a classification of the types of emergencies arisen and allow their rapid identification;
- eliminate as quickly as possible any cause which may affect the safety of persons and of the environment;
- eliminate as quickly as possible any cause which may increase the accident's seriousness or its consequences (escalation);
- initiate the necessary actions in order to maintain and re-establish the functioning of the facilities as appropriate and when safe to do so;
- contact the relevant operators within a reasonable timeframe.

V.2.4 Description of the emergency alarm system

2.4.1 Alarms

The alarm system utilizes two different tones and lights to clearly differentiate alarm category.

2.4.2 Personnel

The operating instructions (commonly referred to on onshore facilities as a "Station Bill") provide guidance to personnel on the actions which are to be taken on initiation of either alarm. Specific reference is made to the duties of workers on the facility who have been assigned specific "emergency response" roles and responsibilities.

2.4.3 Means of communication

The Operating Company utilizes a variety of communication systems to ensure that the location of personnel assigned "emergency response" duties is known to the Operating Company's incident command team.

2.4.4 Available documentation

The cartographic and technical documentation, useful for dealing with and resolving the emergency situation (such as the procedures for the safe operation and the restarting of the facilities) are available in the "Central Control Room", which is used as the incident command centre.

Courtesy translation, not binding.

2.4.5 External communications

The person in charge, designated by the Operating Company, will inform the onshore operations manager of all incidents that initiate the facility alarm systems. The onshore operation manager will ensure that the external subjects indicated below are advised of the incident as soon as reasonably practicable:

- (i) Transportation Company - dispatching;
- (ii) the Prefecture;
- (iii) the Maritime Authority (the officer on guard);
- (iv) the office responsible for police force “Questura”;
- (v) the mayor of Porto Viro;
- (vi) the Municipality’s fire department;
- (vii) the president of the Regional Council;
- (viii) the president of the Municipality’s administration; and
- (ix) the Users.

V.3 EMERGENCY FOR NON SCHEDULED OUT OF SERVICE

Beyond the emergencies for leakage of LNG/Gas indicated in the paragraph above, there may be cases of emergencies which take place for non-scheduled out of service of the Regasification critical devices which cause a reduction of the Regasification capacity with respect to the scheduled quantities.

V.4 INFORMATION IN RELATION TO EMERGENCIES

The Operating Company shall keep track of the following information in relation to the emergencies, being either emergencies of service or for non-scheduled out of service, which indicate the emergencies’ main aspects:

- the type of the emergency;
- the date and time of the event;
- a description of the facilities’ component which is the subject of the intervention;
- any leakages of Gas/LNG that have been registered;
- a description of the event, and of the emergency’s causes;
- the subject which has requested the measure (third parties, fire men, Operating Company, etc.);
- the potential liability for the emergency (Force Majeure, third parties, the Operating Company), once that the competent authorities have ascertained the liabilities

The Operating Company shall communicate to the Regulatory Authority for Electricity and Gas by the 31st of December of each Year, a summary note containing the main information regarding the emergencies of service which took place at the Terminal during the previous Thermal Year.

CHAPTER VI

AMENDMENT OF THE REGASIFICATION CODE

VI.1 GENERAL PRINCIPLES

VI.1.1 Automatic modification for mandatory rules

Pursuant to articles 1339 and 1419, sub-section II of the Italian civil code, the Regasification Code and each Capacity Agreement shall be deemed to be automatically modified and/or supplemented to reflect any mandatory rules provided from time to time by any Regulations.

VI.1.2 Amendments

The following provisions of this chapter VI describe the procedure that will be followed by the Operating Company in the event that it will be necessary to amend and/or supplement the provisions of the Regasification Code in order to:

- (a) conform the Regasification Code to any mandatory rules provided by any Regulations which are partly or wholly incompatible with the Regasification Code and which do not automatically amend and/or supplement the Regasification Code pursuant to articles 1339 and 1419, sub-section II, of the Italian civil code;
- (b) conform the Regasification Code to new technical or market conditions;
- (c) correct material errors within the text of the Regasification Code; or
- (d) render the operation of the Terminal more efficient in light of the experience acquired while providing the Service, particularly during the course of the Start-up Period.

Proposed amendments shall be prepared by the Operating Company, including those in light of the requests given by the entitled subjects, according to the procedures indicated below. The proposed amendments, together with the opinion of the Consultation Committee, shall be filed with the Regulatory Authority for Electricity and Gas in order for it to verify the compliance with the criteria for the preparation of regasification codes and with the general objectives relating to the access and use of LNG regasification plants.

The procedure described below is aimed at:

- (a) allowing the participation of the entitled subjects in the dynamic process for the update of the Regasification Code;
- (b) ensuring that the proposed amendments are consistent with the fundamental principles of the Regasification Code and aid in an effective process;
- (c) ensuring the implementation of the amendments adopted with a timing that is compatible with:

Courtesy translation, not binding.

- (i) the level of technical complexity;
- (ii) the operational challenges that might be encountered by the Operating Company during the course of the Start-up Period;
- (iii) the need to modify the operating processes in place at the Terminal; and
- (iv) the investments which are necessary for the implementation of the adopted amendments.

VI.2 REQUESTS FOR THE AMENDMENT

VI.2.1 Subjects entitled to submit requests for the amendment of the Regasification Code

The subjects who are entitled to submit requests for the amendment of the Regasification Code are:

- (a) The Users on an individual or associated basis ; and
- (b) The other companies (transport and storage) and the associations of distribution companies, limited to issues in which they are directly involved.

Such requests must be submitted to the Operating Company by registered letter anticipated via fax to the addresses indicated on its Electronic Communications System, in accordance with the timeframe indicated below, and can also be forwarded to the Consultation Committee, where appropriate.

VI.2.2 Requirements for the admissibility of the requests

In order to be declared admissible by the Operating Company, each request shall:

- (a) include the information regarding the subject giving the notice (the company, the registered office, etc.) and at least one reference person to be contacted in connection with the request at issue (name, telephone number, fax number and e-mail);
- (b) contain a brief description of the nature of the amendment request;
- (c) indicate the reasons why the subject submitting the request is of the opinion that the amendment should be adopted;
- (d) file any further documentation (analysis, reports, etc.) supporting the amendment;
- (e) indicate a deadline for the entry into force of the request, which can not be earlier than the sending of the request.

VI.2.3 Declaration of admissibility

The Operating Company shall verify the compliance of the notice with the requirements set

Courtesy translation, not binding.

out in clause 2.2 of this chapter VI within 3 (three) Business Days from its receipt. Should one or more of those requirements not be met, the Operating Company shall request the subject who has submitted the request to correct the deficiencies, it being understood that the correction shall be made – under penalty of non admissibility of the same – within 3 (three) Business Days from the request. The period of 20 (twenty) Business Days referred to in Article 2.4 will start following the receipt of the request containing the correction of the deficiencies required by the Operating Company.

In the event that the Operating Company does not express its opinion on the submitted request within 3 (three) Business Days either from the date of the service of the request or of receipt of the requested supplement, the request will be considered admissible.

VI.2.4 Assessment of the request

If the verification of admissibility, as provided in Article 2.3 above, is successful, the Operating Company shall review and evaluate the request based on the following criteria:

- (a) the consistency of the amendments with the Regulations and with the principles of the Regasification Code;
- (b) the modalities through which such proposals contribute to the improvement of the functionality of the Regasification Code; and
- (c) the operational implications on the LNG regasification activity and/or the Service, also in terms of time for the adaptation and costs generated.

During the assessment process, the Operating Company may request additional information and/or clarifications from the subject who has submitted the request.

The requests in relation to which the Operating Company has expressed a positive evaluation will become proposals for the amendment of the Regasification Code.

If the request is rejected, the Operating Company will make the request available to the Regulatory Authority for Electricity and Gas within 20 (twenty) days after receipt by the Operating Company of the modification request that is considered admissible, together with a report outlining the reasons why the Operating Company has decided not to submit it to public consultation. However if the Regulatory Authority for Electricity and Gas finds reason to submit the change request to consultation, the Operating Company will initiate the process for consultation within 15 (fifteen) days from the date of a special notice to that effect by the Regulatory Authority for Electricity and Gas, by notifying the individual concerned.

VI.3 PROPOSALS FOR THE AMENDMENT OF THE REGASIFICATION CODE

VI.3.1 Preparation of the proposals for the amendment

The proposals for the amendment of the Regasification Code shall be prepared by the Operating Company pursuant to article 15, section 2, of AEEG Resolution no. ARG/gas 55/09 of 7 May 2009, also on the basis of the requests submitted by the entitled subjects, for which a positive evaluation has been expressed. The proposals for amendment shall:

Courtesy translation, not binding.

- (a) contain a brief description of the nature of the amendment, indicating the grounds on which the Operating Company bases its decision to adopt the amendment;
- (b) indicate the clauses and chapters of the Regasification Code which are affected by the proposal, together with the amendments to be made to the text of the Regasification Code;
- (c) be accompanied by any documentation (analysis, reports, etc.) which support the need for adopting the proposed amendment;
- (d) indicate a date on which the proposed amendment should become effective.

The Operating Company shall also assign to each proposal a reference number and it will register the proposal in the relevant registry, which shall be kept at the registered office of the Operating Company and be available for consultation by anyone who requests to do so.

VI.3.2 Consultation on the proposed amendment

The Operating Company shall file the proposals for amendment with the Consultation Committee, in accordance with article 3 of AEEG Resolution no. ARG/gas 55/09 of 7 May 2009, its opinion in that respect.

Contemporaneously with the filing of the proposal for amendment with the Consultation Committee, the Operating Company shall publish the proposal for amendment on the Electronic Communication System, in order to enable all interested parties to formulate their own comments on the proposal.

The proposed amendment prepared by the Operating Company in accordance with the decrees, resolutions or other measures issued by the competent authority will be published on the Electronic Communication System within 15 (fifteen) days from the publication of the measure unless the measure itself does not provide a different deadline.

Operating Company may propose amendment at any time of the Thermal Year.

The consultation period lasts:

- a. 45 (forty five) days, or
- b. 30 (thirty) days if the proposed amendment prepared by the Operating Company in accordance with decrees, resolutions or other measures issued by the competent authority, unless the measure provides a deadline

VI.3.3 Filing with the Regulatory Authority for Electricity and Gas of the proposal for amendment

Within 20 (twenty) days from the end of the process described under clause 3.2 above, the Operating Company, in order to allow the compliance assessment and pursuant to the provisions of article 3.7 of AEEG Resolution no. ARG/gas 55/09 of 7 May 2009, shall file with the Regulatory Authority for Electricity and Gas:

Courtesy translation, not binding.

- (a) the proposed amendments of the Regasification Code, as possibly modified in order to take into account the opinions and comments received during the course of the consultation process;
- (b) the related opinions and notices formulated or sent by the Consultation Committee;
- (c) a report illustrating how those opinions and notices have been taken into account.

The above deadline is reduced to 10 (ten) days if the proposed amendment prepared by the Operating Company is in response to decrees, resolutions or other measures issued by the competent authority.

The proposals filed with the Regulatory Authority for Electricity and Gas will be published by the Operating Company on the Electronic Communications System.

Operating Company publish the updated code on the Electronic Communication System within 10 (ten) days of the publication of the update on the website of the Regulatory Authority for Electricity and Gas.

VI.4 COMMUNICATIONS

Any further communications related to the amendment of the Regasification Code or related to this chapter VI shall be sent – by registered letter anticipated via fax – to the address indicated on the Electronic Communication System.

CHAPTER VII

QUALITY OF THE SERVICE

VII.1. INTRODUCTION

The Terminale GNL Adriatico S.r.l. has adopted a policy aimed at achieving and maintaining high quality standards to ensure an adequate degree of reliability of the Regasification Service.

These standards are in line with the principles of efficiency, continuity and impartiality and respect the safety and protection of the environment.

This chapter lists the basic principles that Terminale GNL Adriatico S.r.l. follows in order to ensure an adequate level of meeting the needs of Users in relation to:

- Efficiency of service
- Fairness of treatment
- Continuity of service
- Safety, Health and Environment
- Participation
- Information
- Commercial quality

in addition, areas of intervention in the definition of the quality of the Regasification Service to reach and maintain the principles above are included.

Subject to the minimum legal standards, it is outlined that in the Start-up Period the achievement of the quality of service objectives will be monitored also in order to change and / or supplement the principles.

Terminale GNL Adriatico S.r.l. has adopted a set of rules of conduct and internal tools to monitor the use of its principles and behaviors such as the Code of Ethics and the Integrity Model (text available on the Operating Company's website).

The Code of Ethics has been autonomously adopted with the aim to express the principles of "business ethics" and "internal audit" that the Operating Company recognizes as its own and through which requires compliance by all employees and collaborators.

The Integrity Model responds to requirements of a broader scope, insofar as it represents the synthesis between the objective of Terminale GNL Adriatico S.r.l. to provide itself with Integrity Models such to assure conditions of fairness and transparency in the conduct of company business activities and compliance with the specific provisions of Legislative Decree no. 231 of June 8th, 2001.

In the Regasification Code, the concept of a "Quality of Service" referred to the performance to be guaranteed by the Terminale GNL Adriatico S.r.l. to the User, requires feedback from the Users because they are the main enjoyer and witness of the compliance with the requirements. In addition, the general aspects of quality of service should also be in-line with the final guidelines of the regulations issued by the Regulatory Authority for

Courtesy translation, not binding.

Electricity and Gas.

VII.2. BASIC PRINCIPLES

The fundamental principles the Terminale GNL Adriatico follows to reach the goal of meeting the expectations of its Users are described below.

VII.2.1 Efficiency of Service

This principle requires the identification of organizational, procedural and technical solutions appropriate to adapt the Regasification Service to market needs.

VII.2.2 Impartiality

Terminale GNL Adriatico ensures compliance with the principles of objectivity, neutrality, transparency, impartiality and non-discrimination in the management of the Terminal and, more generally, within company activities.

VII.2.3 Continuity of Service

In the case of any interruption of service due to, including but not limited to, emergencies, the Terminale GNL Adriatico will work to limit any inconvenience arising, take steps to notify Users of such interruptions and, take all measures necessary to restore, in the shortest possible time, the normal operating conditions of the Terminal.

VII.2.4. Safety, Health and Environment

Terminale GNL Adriatico is committed to manage its business in compliance with safety and health requirements.

Terminale GNL Adriatico is also committed to operate in accordance with all applicable laws and, applying the best available technology, to promote and develop a plan of its activities aimed at enhancing natural resources and the protection of the environment for future generations and, to promote initiatives leading to widespread environmental protection.

For optimal management of safety, health and the environment, Terminale GNL Adriatico has adopted an integrated Safety, Security, Health & Environment Management System (SHEMS), which is consistent with and meets the commitments and requirements of international standards for health and safety such as OHSAS 18001 and for the environment such as UNI EN ISO 14001.

The systems also satisfy the requirements and the measures required by law Decree No 334/99 of 17 August 1999 "Implementation of Directive 96/82/EC on the control of major accident hazards involving dangerous substances." This is demonstrated by the Safety Report issued by the Operating Company, which also includes the definition of major hazards and the measures necessary to prevent and limit the consequences to human beings and the environment.

For the Operating Company, environmental protection is a fundamental value of society

Courtesy translation, not binding.

and is compatible with the development of the Company itself, consequently the Operating Company is involved in all aspects of environmental protection and has adopted and complies with the strictest environmental protection standards which are applied to all the working activities.

Terminale GNL Adriatico is committed to manage the Terminal and the mooring and discharge operations of LNG Tankers in compliance with international rules and regulations as per the International Convention for the Safety of Life and Sea (SOLAS) International Convention of the International Maritime Organization (IMO), aimed at protecting the safety of commercial shipping with explicit reference to safety of life on board and, local maritime regulations as per the Safety Ordinance of the Chioggia Harbor Master No 63/2008, which defines, inter alia, detailed rules for navigation in the waters off the Terminal with the aim of ensuring safety.

With the same purpose a no-fly zone above the Terminal has been established.

Within SHEMS the Operating Company has implemented plans and procedures and trained its staff on measures to prevent threats to the security of the Terminal and LNG Tankers.

VII.2.5 Participation

There is a procedure for updating the Regasification Code, opened to current or potential Users, who can make requests for modification / supplementation of the Code, as described in Chapter VI - Amendment of the Regasification Code.

VII.2.6 Information

Terminale GNL Adriatico is committed to making information available to Users regarding their Capacity Agreements, its administrative and accounting situation and other issues related to managing the relationship with the Operating Company.

VII. 3. AREAS OF INTERVENTION

In order to assess the performance of the objectives set forth above, the following areas are reported to identify and monitor parameters and indicators which reflect the quality standards of commercial and technical services.

In defining such parameters, the Operating Company also refers to the "Guidelines for LNG System Operators" (GGPLNG) as defined in the European Regulators Group for Electricity and Gas, to the experience in the field of Regasification including comparisons with other operators at international level and, to quality management systems in line with the best international standards.

VII.3.1 Commercial Quality Standards

Some of the key commercial areas that define the quality of services offered by the Operating Company can be identified as follows:

Courtesy translation, not binding.

1. Method and time to respond to requests for clarification on issues relating to:
 - Access to the Terminal;
 - Capacity Subscription;
 - Allocations;
 - Billing.
2. Response to billing issues relating to the Regasification Service;
3. Compliance with the timing provided in the Regasification Code;
4. Assessment of the degree of User satisfaction through surveys.

VII.3.2 Technical Quality Standards

Some of the key technical areas that allow to define the level of the quality of service provided by the Operating Company can be identified as follows:

1. Compliance with the limits stated in the Regasification Code regarding the number of days of interrupted service for scheduled Terminal maintenance;
2. Use of instruments for measurement to ensure greater levels of accuracy and reliability;
3. Emergency service to ensure safe operation of the Terminal and operational continuity during such events.

VII. 4. STANDARD OF QUALITY OF SERVICE

This chapter describes the standards of commercial and technical quality of the services offered and guaranteed by the Terminale GNL Adriatico.

Terminale GNL Adriatico monitor the standards of paragraphs VII.4.1 and VII.4.2 and the results will be provided to the Regulatory Authority for Electricity and Gas by December 31 of each year, as well as information and data on the evolution of standards during the previous Thermal Year.

VII.4.1 Guaranteed commercial quality standards of service in the Regasification Code:

Courtesy translation, not binding.

Area	Terms subject to guaranteed standards	Guaranteed standards
Three Month Schedule (Chapter II.3.3)	Deadline for acceptance by the Operating Company to the Users' proposed Three Month Schedule	By the 21 st (twenty-first) day of each month or the next Business Day if the 21 st (twenty-first) is not a Business Day
Initial Monthly Redelivery Programme (annex K)	Deadline the Operating Company shall comply with for issuing the Initial Monthly Redelivery Programme and communicate it to the Users	By the 3 rd (third) Business Day before the start of Month <i>M</i>
Invoices (Chapter III.8)	Deadline within which the Operating Company issues invoices with respect to a billing Month	By the 10 th (Tenth) Business Day after sending the Final Monthly Redelivery Profile

VII.4.2 Guaranteed standards of technical quality of service in the Regasification Code:

Area	Terms subject to guaranteed standards	Guaranteed standards
Maintenance days at the Terminal (Chapter II.3.5)	Maintenance activities that affect the Terminal Capacity	Maximum number of days per year of interruption / reduction (30 days equivalent to full Terminal Capacity as per paragraph 3.5 of Chapter II)
Maintenance days at the Terminal (Chapter II.3.5)	Maintenance activities that impact upon the Terminal Capacity	Maximum number of days of interruption / reduction in the planned five-year period (70 days equivalent to full Terminal Capacity) in paragraph 3.5 of Chapter II

Annex (a)

Form of Access Request for all Capacity Agreements other than for any Foundation Capacity Agreement

Instructions for entering Non-Foundation and Spot Capacity Agreements

The paragraphs below are intended to briefly illustrate the content of Annex (a) and provide the Applicants with a description of the actions to be taken to correctly complete and file an Access Request for Available Capacity or Spot Capacity.

1. Content of the Annex

Annex (a) is composed of five parts, which content can be summarised as follows:

- **Part I** contains the form of Access Request to be used by the Applicants who intend to request access to the Service for Non-Foundation or Spot Capacity. Depending on whether an Applicant requests Non-Foundation or Spot Capacity, it will have to attach to its Access Request, *inter alia*, a duly completed and signed copy of the Non-Foundation Capacity Agreement (Part IV) or of the Spot Capacity Agreement (Part V).
- **Part II** contains the form of Access Request to be used by a User who (i) is already a party to a Capacity Agreement with the Operating Company; and (ii) at the date of the Access Request has a positive Capacity Make-up Balance and intends to utilize Capacity Make-up with respect to its Access Request for Non-Foundation Capacity or Spot Capacity.
- **Part III** contains the form of Modified Acceptance for any Non-Foundation Capacity Agreement. This is the form that will be used by the Operating Company in those cases where an Access Request by an Applicant cannot be entirely accepted or cannot be accepted without modifications. In such cases, the Operating Company will send to the relevant Applicant the Modified Acceptance with the amended Non-Foundation Capacity Agreement attached and will request the Applicant, if interested in accepting the proposal, to send back the Non-Foundation Capacity Agreement duly signed.
- **Part IV** contains (i) the form of Non-Foundation Capacity Agreement; (ii) Schedule 1, which shall specify the *Cqs*, the CMr applicable in the determination of the Capacity Charge applicable to the Capacity Agreement; and (iii) the direct agreement for the financing of the Terminal, to be entered into between the Terminal, the User and the financing banks.
- **Part V** contains the form of the Spot Capacity Agreement, including Schedule 1, which shall specify the *Cqs*, the CMr applicable in the determination of the Capacity Charge applicable to the Spot Capacity Agreement.

2. Instructions for completing and filing an Access Request

- 2.1 Depending on the kind of capacity requested and/or the existence of a Capacity Make-Up Balance, the Applicant shall submit its Access Request by completing and filing (i) the appropriate form of Access Request (Part I or Part II); and (ii) the appropriate form of

Courtesy translation, not binding.

Capacity Agreement (Part IV or Part V), together with the related schedules. The instructions for the completion and filing of the form of Access Request and of the form of Capacity Agreement are contained in this paragraph and in paragraph 3 below. A description of the actions to be taken by an Applicant in the event of receipt of a Modified Acceptance sent by the Operating Company is contained in paragraph 4 below.

- 2.2 Form of Access Request. Depending on the subject of the Access Request, the Applicant shall submit its Access Request by completing and filing either of the following application forms, as indicated herein:
- (a) the form of Access Request under Part I shall be used to request access to both Available Non-Foundation Capacity and Spot Capacity. This form of Access Request shall be completed, accordingly, by inserting the relevant section and/or deleting the non-relevant ones, as indicated in footnotes of the form.
 - (b) the form of Access Requests under Part II shall be used by a User which already has a Capacity Agreement with the Operating Company and intends to utilize Capacity Make-up with respect to its Access Request for Available Non-Foundation Capacity or Spot Capacity. The Applicant's Capacity Make-up Balance shall be indicated in the Form of Access Request.
- 2.3 Irrevocability. Please note that all Access Requests shall be irrevocable from the date of submission until the date indicated in the Regasification Code, which varies depending on the subject of the Access Request.
- 2.4 Completion. The Access Request shall be completed by the Applicant by including, *inter alia*, the following information as per letters (a) to (d) of the form:
- (a) the loading port(s);
 - (b) the technical specifications of LNG Tanker(s);
 - (c) the importation agreement held by the Applicant which has to be compatible as to duration and capacity with the terms of the Access Request; and
 - (d) only with respect to Access Requests for Available Capacity, the indication of any of the requirements (indicated under letter (a) (iii) of clause 2.4.2 of chapter II) held by the Applicant which entitle it to a ranking priority in the allocation process.
- 2.5 Representations. The Applicant shall also state within the form of the Access Request (letters (e) and (f) of the form) that both the representations regarding the Applicant's status (mentioned in article 2.4.1 of chapter III) and the fulfilment of the Access Conditions provided in clause 2.4.5 of chapter II of the Regasification Code will be maintained from the date of submission of the Access Request until the date in which the Capacity Agreement is entered into or otherwise the Access Request is rejected, as the case may be.
- 2.6 Documents to be enclosed. Together with the Access Request, the Applicant shall also submit the accompanying required documentation as indicated in the Regasification Code (clause 2.4.6 and 2.4.7), including the Applicant's status; the Applicant representative's

Courtesy translation, not binding.

authority to execute the Access Request; the financial security backing for the Applicant; the import authorization and the existence of importation agreements compatible with the capacity requested.

3. Capacity Agreement

3.1 Filing. Depending on the subject of the Access Request, the Applicant also shall send to the Operating Company an executed copy of the Non-Foundation Capacity Agreement or the Spot Capacity Agreement.

3.2 Completion. The text of the relevant Capacity Agreement shall be completed by inserting in the form, *inter alia*, the following details:

- (i) the Applicant's details;
- (ii) the indication of its priority ranking, in case the Applicant meets any of the criteria giving priority in the allocation process;
- (iii) the quantity of LNG related to the amount of Terminal Capacity which the Applicant intends to subscribe as well as all the other details on the requested Unloading Slots;
- (iv) with respect to Spot Capacity Agreement (Part V of the form) the Applicant shall also indicate in paragraph 2 ("*Scope and duration*") the other details in relation to the requested Unloading Slot;
- (v) the expiry date of the Agreement;
- (vi) where applicable, the application of the User's Capacity Make-up Balance for the payment of all or part of the Capacity Charge due pursuant to the Capacity Agreement;
- (vii) the Applicant's/User's address for communication and notices; and
- (viii) in the event that the Applicant's request relates to a Non-Foundation Capacity Agreement having a duration exceeding one (1) year, Applicant shall include clause 6 of the Non-Foundation Capacity Agreement (allowing the financing of the Terminal).

3.3 Schedule (1). Schedule (1) shall be completed by inserting the *Cqs*, the *CMr* applicable in the determination of the Capacity Charge applicable to the Capacity Agreement, as published by the Operating Company on the Electronic Communication System. Please note that the information that will be published by the Operating Company will contain the discount, if any, that will be applied by the Operating Company to the maximum tariffs approved by the Regulatory Authority for Electricity and Gas during each Thermal Year for which there is Available Capacity published on the Electronic Communication System. Therefore, the Applicant who files the Access Request shall take care to download from the Electronic Communication System of the Operating Company a copy of the file containing such information and duly complete Schedule (1) of the Capacity Agreement with the *Cqs*, the *CMr* applicable in the determination of the Capacity Charge applicable

Courtesy translation, not binding.

to each Thermal Year during which the Capacity Agreement will be effective.

- 3.4 Direct Agreement. In case of Access Requests which, if accepted, would result in a Non-Foundation Capacity Agreement having a duration exceeding one (1) year and, unless otherwise directed in the Electronic Communication System of the Operating Company, the Applicant shall also attach to the Capacity Agreement a duly signed copy of the direct agreement to be entered into between the Terminal, the User and the financing banks (Schedule (2) of Part IV of Annex (a)).

4. Actions to be taken by the Applicant in the event of receipt of a Modified Acceptance

- 4.1 In the event that one or more Access Requests for Non-Foundation Capacity may not be accepted by the Operating Company without modifying one or more of the terms of the Non-Foundation Capacity Agreement attached to such Access Request, the Operating may send to one or more Applicants a Modified Acceptance together with an amended Non-Foundation Capacity Agreement attached thereto.
- 4.2 Such Modified Acceptance is considered as a counter proposal by the Operating Company which shall be irrevocable until the date indicated therein.
- 4.3 If the Applicant receives a Modified Acceptance and determines it is still interested in acquiring the relevant capacity, it shall duly execute for acceptance the Non-Foundation Capacity Agreement attached to the Modified Acceptance and send it to the Operating Company. Please note that the Capacity Agreement shall be considered executed between the Applicant and the Operating Company only when the latter receives notice of the acceptance by the Applicant. Therefore, should the Operating Company receive a copy of the duly signed Non-Foundation Capacity Agreement after the latest Day for the acceptance (that is the 24th July in the Annual Subscription Process and the 6th Business Day of the Subscription Month in the Monthly Subscription Process), the Non-Foundation Capacity Agreement will not be concluded, and the Applicant will be deemed to have rejected the proposed amended Non-Foundation Capacity Agreement.

Part I

Form of Access Request for all Capacity Agreements other than for any Foundation Capacity Agreement

[LETTERHEAD OF THE APPLICANT]

[Place], [date]

To:
Terminale GNL Adriatico S.r.l. (“Operating Company”)
Piazza della Repubblica 14/16
20124 Milan
Italy

For the attention of Capacity Subscription Coordinator

Sirs,

ACCESS REQUEST FOR [AVAILABLE/SPOT]¹ CAPACITY

We refer to the Regasification Code implemented by the Operating Company and approved by the Regulatory Authority for Electricity and Gas on 12 May 2011, by resolution Arg/Gas n° 57/11, providing the conditions for access to the offshore regasification terminal owned by the Operating Company, located approximately 17 km offshore Porto Levante, Italy (the “**Regasification Code**”).

The Operating Company, pursuant to clause 2.3 of chapter II of the Regasification Code, has published on its Electronic Communication System: *[i) the Available Capacity; and ii) the number and the timing, if known, of available Unloading Slots in each Month;][i) the Spot Capacity that is available for subscription, including the commencement date and duration of the Unloading Slot, the Scheduled Arrival Range, the Spot Redelivery Period, and the maximum volume of LNG that can be Unloaded during such Unloading Slot; and ii) the due date and time for submission of Access Requests for such Spot Capacity.]*²

[Applicant] (the “**Applicant**”)³, hereby, requests from the Operating Company access to the Service: (i) starting from the date; (ii) for the quantities; and (iii) on the terms and conditions provided in the attached [Non-Foundation/Spot] Capacity Agreement.

With reference to clause 2.4.6 of chapter II of the Regasification Code, and in addition to the information contained in the attached [Non-Foundation/Spot] Capacity Agreement, [Applicant] hereby states (*dichiara*) that:

- (a) the loading port(s) of the LNG that will be transported to the Delivery Point is(are) [*insert name of loading port(s)*];
- (b) the LNG Tanker(s) that will be used to transport the LNG to the Delivery Point has(have) the following technical specifications: [*insert technical specifications, including tonnage, gross loading capacity and length*];

¹ Delete as appropriate.

² Delete as appropriate.

³ It is understood that, if this Access Request is accepted by the Operating Company without modifications, the Applicant, as a consequence, shall become a User. Therefore, reference to the Applicant in this Access Request corresponds to a reference to the User in the attached Capacity Agreement.

Courtesy translation, not binding.

- (c) it is the holder of an importation agreement(s) compatible as to duration and capacity with the terms of this Access Request, as specified in the attached [*Non-Foundation/Spot*] Capacity Agreement and in letters (a) and (b) above;
- (d) the Representations set forth in clause 2.4.1 of chapter III of the Regasification Code are and will be true and accurate with respect to [*Applicant*], from the date of submission of this Access Request until the date the attached [*Non-Foundation/Spot*] Capacity Agreement is entered into, or this Access Request is rejected, as the case may be;
- (e) [*in the case of acceptance of this Access Request, it will timely act to be enabled to operate at the Virtual Exchange Point and will duly execute, and timely provide the Operating Company with, the documentation required by Snam Rete Gas, in order for the Operating Company to be authorised to operate at the Virtual Exchange Point by making requests for transactions which imply the automatic acceptance by the Users*] [*it is already enabled to operate at the Virtual Exchange Point and, in the case of acceptance of this Access Request, it will duly execute, and timely provide the Operating Company with, the documentation required by Snam Rete Gas in order for the Operating Company to be authorised to operate at the Virtual Exchange Point by making requests for transactions which imply the automatic acceptance by the Users*]⁴;
- (f) it satisfies and will maintain the Access Conditions provided in clause 2.4.5 of chapter II of the Regasification Code from the date of submission of this Access Request until the date the attached [*Non-Foundation/Spot*] Capacity Agreement is entered into; [and
- (g) it meets the following requirements to be granted priority in the allocation of the requested Available Capacity: [*insert any of the following requirements indicated under letter (a)(iii) of clause 2.4.2 of chapter II of the Regasification Code*:
 - (i) *Applicant is an end client or a consortium of end clients who import for self-consumption and is not an electricity producer;*
 - (ii) *Applicant undertakes to offer the entire volume of Gas to be imported at the Virtual Exchange Point, according to transparent and non-discriminatory conditions;*
 - (iii) *Applicant undertakes to offer a quota at least equal to twenty percent (20%) of the volume of Gas to be imported at the Virtual Exchange Point according to transparent and non-discriminatory conditions and, in particular, a quota equal to [insert quota]% of the volume of Gas that it will be Redelivered to it; (iv) Applicant imports from States other than those from which long term importation agreements were in force as of 28 September 2004;*
 - (v) *Applicant holds a total allocated transportation capacity at entry points to the Grid, excluding storage interconnection points, below twenty-five percent 25% of the overall transportation capacity allocated at the same entry points].*⁵

This Access Request is irrevocable, pursuant to article 1329 of the Italian civil code, until [*insert date determined in accordance with clauses 2.4.2 (a)(ii), 2.4.2 (b)(i) or 2.4.3 (a) of chapter II of the Regasification Code, as the case may be*].

⁴ Delete as appropriate.

⁵ To be inserted if applicable and only for Access Requests for Available Capacity. Not to be inserted for Access Requests for Spot Capacity. Please note that Applicants falling under the categories indicated under points (i) and (ii) shall have the right to request Available Capacity for a maximum period of ten (10) years, whilst Applicants falling under the categories indicated under points (iii), (iv) and (v) shall have the right to request Available Capacity for a maximum period of five (5) years.

Courtesy translation, not binding.

In accordance with clauses 2.4.6 (a)(x), 2.4.6 (b)(vi) or 2.4.6 (c) of chapter II, as the case may be⁶, and clause 2.4.7 of chapter II, of the Regasification Code, together with this Access Request and for the purpose of entering into the attached [*Non-Foundation/Spot*] Capacity Agreement, the Applicant submits the following documentation:

[index of documentation attached to the Access Request pursuant and subject to clauses 2.4.6 (a)(x), 2.4.6 (b)(vi) or 2.4.6 (c) of chapter II, as the case may be, and clause 2.4.7 of chapter II, of the Regasification Code]

If you accept this Access Request, please send us a copy of the attached Capacity Agreement signed for acceptance.

[*Applicant*]

By⁷: _____

Title: _____

⁶ Depending upon the Applicant being a company incorporated under the laws of Italy or not, article 2.4.6 (a)(x), article 2.4.6 (b)(vi) or article 2.4.6 (c) of chapter II of the Regasification Code, shall, respectively, apply.

⁷ To be signed by the same person signing the attached Capacity Agreement

Courtesy translation, not binding.

Part II

Form of Access Request for Capacity Make-Up

[LETTERHEAD OF THE APPLICANT]

[Place], [date]

To:

Terminale GNL Adriatico S.r.l. (“Operating Company”)
Piazza della Repubblica 14/16
20124 Milan
Italy

For the attention of Capacity Subscription Coordinator

Sirs,

Access Request for [**NON-FOUNDATION/SPOT**]⁸ CAPACITY utilising CAPACITY MAKE-UP

We refer to the Regasification Code implemented by the Operating Company and approved by the Regulatory Authority for Electricity and Gas on 12 May 2011 by resolution n° ARG/gas 57/11, providing the conditions for access to the offshore regasification terminal owned by the Operating Company, located approximately 17 km offshore Porto Levante, Italy (the “**Regasification Code**”).

The Operating Company, pursuant to clause 2.3 of chapter II of the Regasification Code, has published on its Electronic Communication System: *[i) the Available Capacity; and ii) the number and the timing, if known, of available Unloading Slots in each Month;]**[i) the Spot Capacity that is available for subscription, including the commencement date and duration of the Unloading Slot, the Scheduled Arrival Range, the Spot Redelivery Period, and the maximum volume of LNG that can be Unloaded during such Unloading Slot; and ii) the due date and time for submission of Access Requests for such Spot Capacity.]*⁹

On [insert date] [**Applicant**] (the “**Applicant**”)¹⁰ has entered into a capacity agreement with the Operating Company for the use of the Service;

On the date of this Access Request the Capacity Make-Up Balance (as defined in the Regasification Code) of the Applicant, under the Capacity Agreement mentioned above, amounts to €*[insert amount of Capacity Make-Up Balance]*;

[**Applicant**], hereby, requests from the Operating Company access to the Service: (i) starting from the date; (ii) for the quantities; and (iii) on the terms and conditions provided in the attached [*Non-Foundation/Spot*] Capacity Agreement, as well as for the use of its Capacity Make-Up under the Capacity Agreement mentioned above.

With reference to clause 2.4.6 of chapter II of the Regasification Code, and in addition to the information contained in the attached [*Non-Foundation/Spot*] Capacity Agreement, [**Applicant**] hereby states (*dichiara*) that:

⁸ Delete as appropriate.

⁹ Delete as appropriate.

¹⁰ It is understood that, if this Access Request is accepted by the Operating Company without modifications, the Applicant, as a consequence, shall become a User. Therefore, reference to the Applicant in this Access Request corresponds to a reference to the User in the attached Capacity Agreement.

Courtesy translation, not binding.

- (a) the loading port(s) of the LNG that will be transported to the Delivery Point is(are) *[insert name of loading port(s)]*;
- (b) the LNG Tanker(s) that will be used to transport the LNG to the Delivery Point has(have) the following technical specifications: *[insert technical specifications, including tonnage, gross loading capacity and length]*;
- (c) it is the holder of an importation agreement(s) compatible as to duration and capacity with the terms of this Access Request, as specified in the attached *[Non-Foundation/Spot] Capacity Agreement* and in letters (a) and (b) above;
- (d) the Representations set forth in clause 2.4.1 of chapter III of the Regasification Code are and will be true and accurate with respect to *[Applicant]*, from the date of submission of this Access Request until the date the attached *[Non-Foundation/Spot] Capacity Agreement* is entered into, or this Access Request is rejected, as the case may be;
- (e) *[in the case of acceptance of this Access Request, it will timely act to be enabled to operate at the Virtual Exchange Point and will duly execute, and timely provide the Operating Company with, the documentation required by Snam Rete Gas in order for the Operating Company to be authorised to operate at the Virtual Exchange Point by making requests for transactions which imply the automatic acceptance by the Users] [it is already enabled to operate at the Virtual Exchange Point and, in the case of acceptance of this Access Request, it will duly execute, and timely provide the Operating Company with, the documentation required by Snam Rete Gas in order for the Operating Company to be authorised to operate at the Virtual Exchange Point by making requests for transactions which imply the automatic acceptance by the Users]*¹¹;
- (f) it satisfies and will maintain the Access Conditions provided in clause 2.4.5 of chapter II of the Regasification Code from the date of submission of this Access Request until the date the attached *[Non-Foundation/Spot] Capacity Agreement* is entered into; [and
- (g) it meets the following requirements to be granted priority in the allocation of the requested Available Capacity: *[insert any of the following requirements indicated under letter (a)(iii) of clause 2.4.2 of chapter II of the Regasification Code:*
 - (i) *Applicant is an end client or a consortium of end clients who import for self-consumption and is not an electricity producer;*
 - (ii) *Applicant undertakes to offer the entire volume of Gas to be imported at the Virtual Exchange Point, according to transparent and non-discriminatory conditions;*
 - (iii) *Applicant undertakes to offer a quota at least equal to twenty percent (20%) of the volume of Gas to be imported at the Virtual Exchange Point according to transparent and non-discriminatory conditions and, in particular, a quota equal to [insert quota]% of the volume of Gas that it will be Redelivered to it;*
 - (iv) *Applicant imports from States other than those from which long term importation agreements were in force as of 28 September 2004;*
 - (v) *Applicant holds a total allocated transportation capacity at entry points to the Grid, excluding storage interconnection points, below 25% of the overall transportation capacity allocated at the same entry points];*¹²

¹¹ Delete as appropriate.

¹² To be inserted if applicable and only for Access Requests for Available Capacity. Not to be inserted for access

Courtesy translation, not binding.

This Access Request is irrevocable, pursuant to article 1329 of the Italian civil code, until *[insert date determined in accordance with clauses 2.4.2 (a)(ii), 2.4.2 (b)(i) or 2.4.3 (a) of chapter II of the Regasification Code, as the case may be]*.

In accordance with clauses 2.4.6 (a)(x), 2.4.6 (b)(vi) or 2.4.6 (c) of chapter II, as the case may be¹³, and clause 2.4.7 of chapter II, of the Regasification Code, together with this Access Request and for the purpose of entering into the attached *[Non-Foundation/Spot]* Capacity Agreement, the Applicant submits the following documentation:

[index of documentation attached to the Access Request pursuant and subject to clauses 2.4.6 (a)(x), 2.4.6 (b)(vi) or 2.4.6 (c) of chapter II, as the case may be, and clause 2.4.7 of chapter II, of the Regasification Code]

If you accept this Access Request, please send us a copy of the attached Capacity Agreement signed for acceptance.

[Applicant]

By¹⁴: _____

Title: _____

requests for Spot Capacity. Please note that Applicants falling under the categories indicated under points (i) and (ii) shall have the right to request Available Capacity for a maximum period of ten (10) years, whilst Applicants falling under the categories indicated under points (iii), (iv) and (v) shall have the right to request Available Capacity for a maximum period of five (5) years.

¹³ Depending upon the Applicant being a company incorporated under the laws of Italy or not, article 2.4.6 (a)(x), article 2.4.6 (b)(vi) or article 2.4.6 (c) of chapter II of the Regasification Code, shall, respectively, apply.

¹⁴ To be signed by the same person signing the attached Capacity Agreement

Courtesy translation, not binding.

Part III

Form of Modified Acceptance for Non-Foundation Capacity Agreement

[LETTERHEAD OF THE OPERATING COMPANY]

[Place], [date]

To:

[*Applicant*]
(hereinafter the **Applicant**)¹⁵
[*Applicant's address*]

For the attention of Capacity Subscription Coordinator
Sirs,

MODIFIED ACCEPTANCE FOR NON-FOUNDATION CAPACITY

We refer to the access request you submitted on [insert date] (the “**Access Request**”) requesting access to our offshore regasification terminal, located approximately 17 km offshore Porto Levante, Italy, under the term and conditions of our Regasification Code, as approved by the Regulatory Authority for Electricity and Gas on 12 May 2011 by resolution n° Arg/Gas n° 57/11 (the “**Regasification Code**”).

Your Access Request can not be accepted without modification of one or more of the terms of the Non-Foundation Capacity Agreement attached to it, as specified in the Non-Foundation Capacity Agreement attached herewith.

This Modified Acceptance and the attached Non-Foundation Capacity Agreement is sent to you pursuant to clauses 2.4.2 (a)(vii)(bb) or 2.4.2 (b)(iii)(bb) of chapter II of the Regasification Code (as the case may be) and it is an irrevocable contractual proposal (proposta irrevocabile), pursuant to article 1329 of the Italian civil code, until [insert date determined in accordance with clauses 2.4.2 (a)(vii)(bb) or 2.4.2 (b)(iii)(bb) of chapter II of the Regasification Code, as the case may be].

[We draw your attention to the fact that the Available Capacity, which is the object of this Modified Acceptance, is also the object of Modified Acceptances sent by the Operating Company to other Applicant(s) with higher ranking Access Request(s). Therefore, in case of Acceptance by the Applicant of this Modified Acceptance, the resulting Non-Foundation Capacity Agreement attached here below, shall be subject to the condition precedent that such other Applicant(s) does(do) not Accept its (their) respective Modified Acceptance(s) pursuant to clause 2.4.2 (a)(viii) or 2.4.2 (b)(iv) of chapter II of the Regasification Code, in accordance with clause 8 of the attached Non-Foundation Capacity Agreement.]¹⁶

If you accept this Modified Acceptance, please sign the attached Capacity Agreement and send it to us prior to the time that the irrevocable contractual proposal set forth herein expires.

Terminale GNL Adriatico S.r.l.

By: _____

¹⁵ It is understood that, if this Modified Acceptance is accepted by the Applicant, the Applicant, as a consequence, shall become a User. Therefore, reference to the Applicant in this Modified Acceptance corresponds to a reference to the User in the attached Non-Foundation Capacity Agreement.

¹⁶ To be inserted if applicable.

Courtesy translation, not binding.

Title: _____

Part IV

Non-Foundation Capacity Agreement

This Non-Foundation Capacity Agreement (the “**Capacity Agreement**”), is entered into between [User], a company incorporated and existing under the laws of [User’ State of incorporation], registered with the [User’s Registered Office] under number [registration number], tax code number [tax code number], whose principal office is located at [User’s address] (the “**User**”)¹⁷ and **Terminale GNL Adriatico S.r.l.**, a company incorporated and existing under the laws of the Republic of Italy, registered with the Milan *Registro delle Imprese* under number 1788519, fiscal code/VAT code number 13289520150 and whose principal office is located at Piazza della Repubblica 14/16, 20124 Milan, Italy (“**Operating Company**”). Collectively, the User and the Operating Company are referred to herein as the “**Parties**”.

RECITALS

On 15 February 2010 the Operating Company has implemented an Regasification Code (the “**Regasification Code**”) providing the conditions for access to the offshore regasification terminal owned by the Operating Company located approximately 17 km offshore Porto Levante, Italy,

On 12 May 2011 the Regasification Code has been approved by the Regulatory Authority for Electricity and Gas, by resolution Arg/Gas n° 57/11 pursuant to article 24, sub-section V of the legislative decree no. 164/2000;

The Operating Company, pursuant to clause 2.3 of chapter II of the Regasification Code, has published on its Electronic Communication System: i) the Available Capacity; and ii) the number and the timing, if known, of available Unloading Slots in each Month;

On [insert date] the User has submitted an Access Request for [Available Capacity/Available Capacity utilizing Capacity Make-up]¹⁸ pursuant to article 2.4.2 of chapter II, including, *inter alia*, the information and statements specified in clause 2.4.6 (a) of chapter II of the Regasification Code [and stating, in particular, that it met certain requirements to be granted priority in the allocation of the requested Available Capacity. Namely, the User stated that (insert statement(s) made under letter g) of the Access Request for Available Capacity/Access Request for Capacity Make-up)]¹⁹.

NOW, THEREFORE, the User and the Operating Company agree to be legally bound as follows: (*TUTTO CIÒ PREMESSO E CONSIDERATO, l’Utilizzatore ed il Gestore concordano quanto segue:*)

1. Recitals and Definitions

1.1 The recitals are hereby incorporated and form an integral and essential part of this agreement.

1.2 All the capitalized terms used in the Capacity Agreement shall have the same meaning given in clause 1.1 of chapter I of the Regasification Code.

¹⁷ It is understood that the Applicant shall only become a User upon, and as a consequence of, the acceptance of the Access Request or the Modified Acceptance (to which this Agreement is attached) by the Operating Company or the Applicant, respectively, as the case may be. Therefore, prior to completion of this Agreement, reference to the User in this Agreement shall be considered as a reference to the Applicant.

¹⁸ Delete as appropriate.

¹⁹ To be inserted if applicable, including the statement relating to the priority ranking criterion(a) made under letter d) of the relevant Access Request.

Courtesy translation, not binding.

2. Scope and duration

2.1 The Operating Company allocates to the User, and the User subscribes for the Non-Foundation Capacity for the quantities as follows. (*Il Gestore conferisce all'Utilizzatore, e l'Utilizzatore sottoscrive, la Capacità Regolata per le quantità di seguito indicate*)

Volume of LNG (m ³ /Unloading Slot)	Year and Month	Number of Unloading Slots (for each Month)	Timing (if applicable) of each Unloading Slot	Non-Foundation Capacity Subscribed (indicative energy value in TJ)
--	----------------	--	---	--

2.2 The Capacity Agreement shall expire on *[insert date corresponding to the ninetieth (90th) Day after the date of the last Unloading requested]*. Expiration of this Capacity Agreement shall be without prejudice to any obligations and/or liabilities which have accrued prior to the expiration date.)

3. Charges

3.1 The Capacity Charge and the Variable Charge due by the User pursuant to the Capacity Agreement shall be determined in accordance with the relevant provisions of the Regasification Code by applying the *Cqs*, the CMr as set forth in Schedule (1) hereto.

3.2 The Grid Capacity Charge and the Variable Transportation Charge due by the User pursuant to the Capacity Agreement shall be determined in accordance with letters (d) and (e), respectively, of clause 8.1.1 of chapter III of the Regasification Code.

3.3 The Additional Charges and any other payments due by the User pursuant to the Capacity Agreement shall be determined in accordance with the relevant provisions of the Regasification Code.

3.4 [The Operating Company shall apply the User's Capacity Make-Up Balance under the capacity agreement dated *[date of relevant capacity agreement]* for the payment of all or part of the Capacity Charge due pursuant to the Capacity Agreement, in accordance with clause 8.10.2 of chapter III of the Regasification Code.]²⁰

4. Service Conditions

4.1 [*User*] states that it satisfies and will satisfy and maintain all of the Service Conditions provided in clause 2.3 of chapter III of the Regasification Code throughout the term of the Capacity Agreement.

4.2 With particular reference to the Service Condition provided under letter (j) of clause 2.3 of chapter III, [*User*] acknowledges that the provision to the Operating Company of a duly executed authorisation to make requests for transactions at the System which imply the automatic acceptance of the User is essential in order for the Operating Company to be able to Redeliver the Gas. Therefore, [*User*] undertakes to provide the Operating Company with a duly executed copy of such authorization, as well as of any other documentation required by Snam Rete Gas in this respect, within two (2) Days from the execution of this agreement or, should such date fall later than the

²⁰ To be inserted if applicable.

Courtesy translation, not binding.

fifth (5th) Business Day preceding the date when the first Unloading is requested, immediately after the execution of this agreement.

4.3 [User] hereby represents and warrants to the Operating Company that the Representations set forth in clauses 2.4.1 (a) through 2.4.1 (d) of chapter III of the Regasification Code are true and accurate as of the date on which the Capacity Agreement is entered into. In respect of the Representations set forth in clauses 2.4.1 (a) and 2.4.1 (b) of chapter III of the Regasification Code, [User] undertakes that they will remain true and accurate as provided for in clauses 2.4.2 and 2.4.3 of chapter III of the Regasification Code.

5. Domicile election and notices

5.1 According to clause 4.2 of chapter I of the Regasification Code and for the purposes of the Capacity Agreement, the User elects domicile at [insert address] in Milan, and undertakes to maintain such a domicile in Milan, for the entire duration of this Capacity Agreement.

5.2 Any communication and notice to the User made by the Operating Company pursuant to clause 16 of chapter III of the Regasification Code, shall be sent at the address set out in article 5.1 above to the attention of Mr. [insert addressee], fax number [insert fax number], e-mail address [insert e-mail address].

6. [Financing of the Terminal]²¹

6.1 At the request of the Operating Company the User agrees: (i) to allow the Operating Company to create a security interest in favour of the Operating Company's lenders in this Capacity Agreement; and (ii) to enter into a direct agreement with [Operating Company's lenders] (the "Lenders").

6.2 The direct agreement is attached to this Capacity Agreement as Schedule (2).]

7. Application of the Regasification Code

This Capacity Agreement is subject to the terms and conditions of the Regasification Code, which are incorporated herein by reference.

[8. Condition Precedent

The Capacity Agreement is subject to the condition precedent that the other Applicant(s) with higher ranking Access Request(s) does(do) not Accept its (their) respective Modified Acceptance(s) pursuant to clause 2.4.2 (a)(viii) or 2.4.2 (b)(iv) of chapter II of the Regasification Code.]²²

[Place], [date]

[Applicant]

By: _____

Title: _____

²¹ To be deleted for Access Requests aimed at entering into Non-Foundation Capacity Agreements with a term of up to 1 (one) year.

²² To be inserted if applicable.

Courtesy translation, not binding.

The User, hereby, unconditionally approves, pursuant to and for the purposes of, articles 1341 and 1342 of the Italian Civil Code, the following articles of the Regasification Code:

CHAPTER I:

4.1 “Competence of the Regulatory Authority for Electricity and Gas”; **4.2** “Submission to jurisdiction”; **4.3** “Arbitration of Technical Disputes”.

CHAPTER II:

2.1.1 “Provisional Terminal Capacity”; **2.4.2** “Subscription of Available Capacity”; **2.4.3** “Subscription of Spot Capacity”; **2.4.6** “Access Requests”; **2.4.8** “Execution of Modified Acceptances”; **2.5** “Access Denial”; **2.6** “Released Capacity”; **2.7** “Subscribed Non-Foundation Capacity to be made available to the Operating Company for allocation to third parties pursuant to article 11, sub section 3, of AEEG Resolution no 167 of 1 August 2005”; **2.8** “Subscribed Foundation Capacity to be made available to the Operating Company for allocation to third parties pursuant to article 6, sub section 3, of the MAP decree of 11 April 2006”; **3.2** “Annual Scheduling”; **3.3** “Three (3) Month Scheduling”; **3.7** “Unloading Slot unavailability”.

CHAPTER III:

2.2 “Parties’ obligations”; **2.6** “User’s standard of performance”; **2.7** “Refusal of changes in the Service”; **2.9** “Performance of the Redelivery Service”; **3** “Withdrawal from and duration of capacity agreements”; **4** “Title”; **5.1.3** “Determination of quantity and quality of LNG at the Delivery Point”; **5.1.4** “Adjustment of within spec LNG”; **5.1.7** “User’s liability in relation to Unloading of Off-Spec LNG”; **6.1** “Redelivery of Gas”; **6.2** “Losses and Consumption”; **7** “Force Majeure”; **8.1** “Invoicing by the Operating Company”; **8.4** “Suspension of payment of invoices”; **8.6** “Adjustment of Errors”; **8.7** “No deduction of taxes; liability for Maritime Charges”; **8.10** “Capacity Make-Up”; **8.11** “Charges for scheduling variance applicable to Continuous Users”; **8.12** “Charges for scheduling variance applicable to Spot Capacity”; **9** “Taxes, duties and charges on the Gas”; **12** “Exchanges of Subscribed Capacity”; **13** “Termination”; **14** “Liability”; **15** “Complaints”; **19** “Enforcement Costs”; **20** “Waiver of immunity”.

CHAPTER IV:

1.3 “Rejection of LNG Tankers”; **1.4.2** “Failure to make necessary modifications”; **3.6** “Re-Assignment of Berth”; **3.8.2** “Demurrage”; **3.9** “Excess of boil-off”.

CHAPTER VI:

2.1 “Subjects entitled to submit requests for the amendment of the Regasification Code”; **2.2** “Requirements for the admissibility of the requests”; **2.4** “Assessment of the request”; **4** “Communications”.

ANNEX (a):

Instructions for entering Non-Foundation and Spot Capacity Agreements: **2.3** “Irrevocability”; **4.2;** **4.3;**

Part I – Form of Access Request for all Capacity Agreements other than for any Foundation Capacity Agreement: **paragraph after letter (g);**

Part II – Form Access Request for Capacity Make-up: **paragraph after letter (g);**

Part III – Form of Modified Acceptance for Non-Foundation Capacity Agreement: **third paragraph;**

Courtesy translation, not binding.

Part IV – Non-Foundation Capacity Agreement: clause **5** “*Domicile election and notices*”; clause **6** “*Financing of the Terminal*”.

Schedule (2) - Direct Agreement: Recital E; clause **2** “*Consent to assignment and Step-In Rights*”; clause **3** “*Payments under the Capacity Agreement*”; clause **6.7** “*Arbitration*”; clause **6.9** “*Termination*”; clause **6.10** “*Conflicts of documents*”.

Part V – Spot Capacity Agreement: clause **5** “*Domicile election and notices*”

ANNEX (e) – Form of Release Declaration: **last paragraph**.

The list of “unfair terms” (“*clausole vessatorie*”) shall be modified or integrated in accordance with the amendments to the Regasification Code (if any) required by the Regulatory Authority for Electricity and Gas.

[Applicant]

By: _____

Title: _____

For Acceptance:

Terminale GNL Adriatico S.r.l.

By: _____

Title: _____

Courtesy translation, not binding.

Schedule (1)

[User to insert Schedule (1) as published by the Operating Company on the Electronic Communication System, with respect to the capacity which is the object, and for the term, of the Capacity Agreement.]

Schedule (2)

DIRECT AGREEMENT

THIS AGREEMENT (the **Direct Agreement** or the **Agreement**), dated as of [●], is entered into between:

- (a) Terminale GNL Adriatico S.r.l, with registered office in Piazza della Repubblica 14/16, 20124 Milan and registered with the Milan *Registro delle Imprese* under no. 1788519, VAT and tax code no. 13289520150, (the **Borrower**);
- (b) [●], with registered office in [●] and registered with the [●] *Registro delle Imprese* under no. [●], VAT and tax code no. [●](the **User**); and
- (c) [●], with registered office in [●], registered with the [●] *Registro delle Imprese* under no. [●] and with the Banks' Register under no. [●], VAT and tax code no. [●], as facility agent acting in the name and on behalf of the banks which are parties of the Finance Documents (as defined below) and listed in Exhibit A hereto (the **Finance Parties**) (the facility agent, together with its successors in such capacity, the **Facility Agent**

(each of them hereinafter the **Party** and, collectively, the **Parties**).

RECITALS

A. The Project. The Borrower is in the process of implementing a project to build and operate an offshore plant (the **Terminal**) located at an approximate water depth of 30 metres in the Adriatic Sea in Italian territorial waters at approximately lat. 45°05', long. 12°35' approximately 17 km offshore Porto Levante (the **Project**).

B. The Capacity Agreement. The User and the Borrower have entered into a Non-Foundation Capacity Agreement dated [●], which is subject to the terms and conditions stated in the Regasification code providing the conditions for access to the Terminal, pursuant to Article 24, sub-section V, of the legislative decree no. 164 of 23rd May 2000 (the **Regasification Code**) dated [●] (as amended, supplemented or otherwise modified, the **Capacity Agreement**).

C. The Finance Documents. On [●], the Borrower has entered into certain finance documents (as amended, supplemented or otherwise modified, the **Finance Documents**), among which a facility agreement (the **Facility Agreement**), pursuant to which the Finance Parties have undertaken to extend credit to the Borrower on a *project finance* basis for the purposes of financing the cost of the Project and certain related expenses, up to an amount equal to €[●].

D. The Facility Agent. Pursuant to Article [●] of the Facility Agreement, [●]²³ has been appointed as agent for the Finance Parties, with full power and capacity to act in their name and on their behalf.

E. The Assignment of Receivables. The Borrower and the Facility Agent are going to enter into an assignment of receivables (the **Assignment of Receivables**), as security for the Borrower's obligations under the Finance Documents, under which the Borrower shall assign all of its receivables under the Capacity Agreement, including all of its rights to receive payment under or with respect to the Capacity Agreement and all payments due and to become due to the Borrower under or with respect to the Capacity Agreement, to the Facility Agent, acting in the name and on behalf of the Finance Parties.

NOW, THEREFORE, the Parties hereby agree as follows:

²³ To be filled with the name of the bank under (c) above, in its capacity of Facility Agent.

Courtesy translation, not binding.

ARTICLE 1. - RECITALS AND ANNEXES

Recitals and Annexes form integral and substantial part of this Agreement.

ARTICLE 2. CONSENT TO ASSIGNMENT AND STEP-IN RIGHTS

2.1 Consent to Assignment. The User (a) hereby consents in all respects to the assignment to the Facility Agent pursuant to the Assignment of Receivables of all of the Borrower's receivables under the Capacity Agreement, including the Borrower's right to receive payments from the User; (b) acknowledges that the Borrower may not, without the prior written consent of the Facility Agent, amend, modify, vary, terminate or supplement the Capacity Agreement or take any action that would result in any of the foregoing; unless the above events are mandatorily imposed by law; (c) consents that the Borrower may, with the prior written consent of the Facility Agent, assign (in whole or in part) the Capacity Agreement or subcontract (in whole or in part) the performance of the Service and/or of any service relating to the Service to a third party, provided that the third party has the financial and technical status and capability to perform the obligations and exercise the rights of the Borrower under the Capacity Agreement; and (d) consents to any transfer of the Capacity Agreement which might result from any merger, de-merger or conversion of the legal status of the Borrower, as well as from any transfer or lease of the Borrower's going concern.

2.2 Step-In Rights. The User and the Borrower hereby acknowledge and consent that the Facility Agent, in the name and on behalf of the Finance Parties and upon written notice to the User, shall be entitled, in case an event of default has occurred and is continuing under the Finance Documents, to transfer, at the terms and conditions provided under the Facility Agreement (of which the User shall be duly and timely informed), the contractual position of the Operating Company to a third party appointed by the Banks (the **Appointed Transferee**), provided that the Appointed Transferee, once appointed, formally declares to take over the whole contractual position of the Borrower under the Capacity Agreement, and provided further that such transfer does not alter or prejudice the tax position of the User under the Capacity Agreement (including without limitation, by way of adversely impacting on the deductibility of the regasification fee or other operating costs).

2.3 Right to Cure. In the event of a default or breach by the Borrower in the performance of any of its obligations under the Capacity Agreement, or upon the occurrence or non-occurrence of any event or condition under the Capacity Agreement that would immediately or with the passage of any applicable grace period or the giving of notice, or both, enable the User to suspend or terminate the Capacity Agreement (a **Default**), the User will not terminate the Capacity Agreement until it first gives prompt written notice of such Default to the Borrower and the Facility Agent.

Then, within a period of at least (i) [60] days, in respect of a non-payment default, and (ii) [45] days, in respect of a payment default from the giving of such notice, the Facility Agent, acting in the name and on behalf of the Finance Parties, will be entitled to notify to the User the Finance Parties' intention to cure the Default or, alternatively, to have the Borrower or a third party to cure it.

In this case, the Banks will be entitled, within the following [60] days, to:

- (a) appoint an Appointed Transferee, which will take over the whole contractual position of the Operating Company under the relevant Capacity Agreement; or
- (b) to cure, either directly or indirectly, the Borrower's breach which might trigger the termination; or

Courtesy translation, not binding.

- (c) notify to the User that the attempt to (i) replace the Operating Company in its contractual position under the Capacity Agreement or (ii) cure the Borrower's breach has failed,

provided that:

- (1) in the cases under (a) and (b) above, the User shall not suspend the performance of the relevant Capacity Agreement.
- (2) if the Facility Agent is prohibited from curing any such Default by any process, stay or injunction issued by any governmental authority or pursuant to any bankruptcy or insolvency proceeding involving the Borrower, then the time period specified herein for curing a Default shall be extended for the period of such prohibition but in no event longer than [180] days.

2.4 No Amendments. The User agrees that it will not, without the prior written consent of the Facility Agent, acting in the name and on behalf of the Finance Parties (i) enter into or agree to any material amendment, supplement, transfer, suspension, novation, extension, restatement or other material modification of the Capacity Agreement or any material term or condition thereof, unless the above events are mandatorily imposed by law (ii) enter into or agree to any consensual suspension, cancellation, or termination of the Capacity Agreement, (iii) assign or otherwise transfer any of its right, title or interest under the Capacity Agreement.

2.5 No Liability. The User acknowledges and agrees that neither the Facility Agent nor its designees nor the Finance Parties shall have any liability or obligation under the Capacity Agreement as a result of this Direct Agreement, nor shall the Facility Agent or its designees be obligated or required to (a) perform any of the Borrower's obligations under the Capacity Agreement, except when the Facility Agent, acting in the name and on behalf of the Finance Parties, has expressly stated its intention to cure directly any of the Borrower's breach, as provided under Article 2.3 (b) above, in which case the rights and obligations of the Facility Agent shall be no more than those of the Borrower under the Capacity Agreement or (b) take any action to collect or enforce any claim for receivables, relating to payment obligations, assigned under the Assignment of Receivables, except in the cases and at the terms and conditions provided thereunder.

2.6 Performance under Capacity Agreement. The User shall perform and comply with all material terms and provisions of the Capacity Agreement to be performed or complied with by it and shall maintain the Capacity Agreement in full force and effect in accordance with its terms.

2.7 Delivery of Notices. The User shall deliver to the Facility Agent and its designees, concurrently with the delivery thereof to the Borrower, a copy of each material notice, request or demand given by the User pursuant to the Capacity Agreement.

2.8 Delivery of Financial Statements. On or prior to the date hereof, the User has delivered to the Facility Agent a copy of its annual audited financial statement (**Financial Statement**) for its most recent fiscal year. Within ninety (90) days after the close of each of its fiscal year, the User shall deliver to the Facility Agent annual audited Financial Statements, prepared in accordance with the International Accounting Standards or should the User not be subject to International Accounting Standards, to generally accepted accounting principles in the jurisdiction of formation of the User, certified by a reputable independent certified public accountant.

ARTICLE 3. - PAYMENTS UNDER THE CAPACITY AGREEMENT

3.1 Payments. The User shall pay all amounts payable by it to the Borrower under the Capacity Agreement in the manner required by the Capacity Agreement directly into the account specified in

Courtesy translation, not binding.

Exhibit B hereto, or to such other person or account as shall be specified from time to time by the Facility Agent to the User in writing in accordance with the relevant finance documentation. The Borrower hereby authorizes and directs the User to make such payments as aforesaid.

- 3.2 No Offset, etc. All payments required to be made by the User to the Borrower under the Capacity Agreement shall be made without any offset, recoupment, abatement, withholding, reduction or defence whatsoever, other than those offsets, recoupments, abatements, withholdings, reductions and defence permitted under applicable law or expressly allowed by the terms of the Capacity Agreement.

ARTICLE 4. - REPRESENTATIONS AND WARRANTIES OF THE USER

The User makes the following representations and warranties, as of the date of execution and delivery of this Direct Agreement and the Capacity Agreement.

- 4.1 Status. The User is a duly incorporated, organised and validly existing company under the laws of jurisdiction of its incorporation, and has all requisite corporate power and authority to execute this Direct Agreement and the Capacity Agreement and perform its obligations thereunder.
- 4.2 Authorisation; No Conflict. The User has duly authorized and executed this Direct Agreement and the Capacity Agreement. Neither the execution of this Direct Agreement and the Capacity Agreement by the User nor its consummation of the transactions contemplated thereby nor its compliance with the terms thereof does or will require any consent or approval not already obtained, or will conflict with the User's formation documents or any contract or agreement binding on it.
- 4.3 Legality, Validity and Enforceability. Each of this Direct Agreement and the Capacity Agreement is in full force and effect and is a legal, valid and binding obligation of the User, enforceable against the User in accordance with its terms.
- 4.4 Governmental Consents. There are no governmental consents existing as of the date of this Direct Agreement that are required or will become required to be obtained by the User in connection with the execution, delivery or performance of this Direct Agreement and the Capacity Agreement and the consummation of the transactions contemplated thereunder, other than those governmental consents which have been obtained and are in full force and effect.
- 4.5 Litigation. There are no pending or, to the User's knowledge, threatened in writing actions, suits, proceedings or investigations or any kind (including arbitration proceedings) to which the User is a party or is subject, or by which it or any of its properties are bound, that if adversely determined to or against the User, could reasonably be expected to materially and adversely affect the ability of the User to execute and deliver the Capacity Agreement and this Direct Agreement or for the User to perform its obligations thereunder or hereunder.
- 4.6 Existing Defaults. The User is not in default under the Capacity Agreement.
- 4.7 No Previous Assignments. The User has no notice of, and has not consented to, any previous assignment by the Borrower of all or any part of its rights under any Capacity Agreement.
- 4.8 Representations and Warranties. All representations, warranties and other statements made by the User in the Capacity Agreement were true and correct as of the date when made.

ARTICLE 5. - OPINION OF COUNSEL

On or before [●], the User shall deliver, upon request by the Facility Agent a legal opinion of its legal

Courtesy translation, not binding.

counsel relating to the User's signatory powers with respect to the Capacity Agreement, this Direct Agreement, any other material agreement to which the User is a party, in form and substance acceptable to the Facility Agent.

ARTICLE 6. - MISCELLANEOUS

- 6.1 Notices. All notices or other communications required or permitted to be given hereunder shall be in writing and shall be considered as properly given (a) if delivered in person, (b) if sent by registered mail with return receipt or (c) if sent by prepaid telex, or by telecopy with correct answer back received. Notices shall be directed (i) if to the User, in accordance with the Capacity Agreement, and (ii) if to the Facility Agent, to [●]. Notice so given shall be effective upon receipt by the addressee. Any party hereto may change its address for notice hereunder to any other location by giving no less than twenty (20) days notice to the other parties in the manner set forth above in this paragraph.
- 6.2 Further Assurances. The User shall fully cooperate with the Facility Agent and perform all additional acts reasonably requested by the Facility Agent to effect the purposes of this Direct Agreement, including as may be required to perfect the Finance Parties' interest in the Capacity Agreement.
- 6.3 Amendments. This Direct Agreement may not be amended, changed, waived, discharged, terminated or otherwise modified unless such amendment, change, waiver, discharge, termination or modification is in writing and signed by each of the Parties.
- 6.4 Entire Agreement. This Direct Agreement and any agreement, document or instrument attached hereto or referred to herein integrate all the terms and conditions mentioned herein or incidental hereto.
- 6.5 Governing Law. This Direct Agreement shall be governed by the laws of Italy.
- 6.6 Severability. In case any one or more of the provisions contained in this Direct Agreement should be invalid, illegal or unenforceable in any respect, the validity, legality and enforceability of the remaining provisions shall not in any way be affected or impaired thereby, and the Parties shall enter into good faith negotiations to replace the invalid, illegal or unenforceable provision with a view to obtaining the same commercial effect as this Direct Agreement would have had if such provision had been legal, valid and enforceable.
- 6.7 Arbitration. If any dispute, controversy or claim arises in relation to or under this Direct Agreement, any party hereto may, by notice to the other parties, refer the dispute to be finally settled by arbitration. Such arbitration shall be conducted in accordance with the Rules of Arbitration of the International Chamber of Commerce (the **ICC Rules**) prevailing and in effect as at the date the matter is referred to arbitration. The number of arbitrators shall be three (3) and they shall be appointed in accordance with the ICC Rules; in particular where there are multiple respondent, they, jointly, shall nominate an arbitrator for confirmation pursuant to Article 9 and 10 of the ICC Rules. In the absence of such a joint nomination and where the respondents are unable to agree to appoint an arbitrator, this appointment shall be made by the ICC International Court of Arbitration. The third arbitrator, who will act as chairman of the Arbitral Tribunal, shall be appointed by the Court. Arbitration shall be conducted in the English language and the place of arbitration shall be Rome, Italy. The decision of the arbitration panel shall include a statement of the reasons for such decision and, shall be final and binding on the parties thereto, subject to the provisions set forth under Article 29 of the ICC Rules.
- 6.8 Successors and Assignees. The provisions of this Direct Agreement shall be binding upon and inure to the benefit of the parties hereto and their permitted successors and assignees.

Courtesy translation, not binding.

6.9 Termination. The User's obligations hereunder are absolute and unconditional, and the User shall have no right to terminate this Direct Agreement or to be released, relieved or discharged from any obligation or liability hereunder so long as the User shall have any commitments outstanding under the Capacity Agreement and until all its obligations thereunder shall have been indefeasibly satisfied in full.

6.10 Conflicts of Documents. In the event of any conflict between the provisions of this Direct Agreement and the provisions of the Capacity Agreement, the provisions of this Direct Agreement shall prevail.

[Date]

[Name of the User]

as the User

By: _____

Name:

Title:

[Name of Facility Agent]

as the Facility Agent

By: _____

Name:

Title:

TERMINALE GNL ADRIATICO S.R.L.

as the Borrower

By: _____

Name:

Title:

Courtesy translation, not binding.

Exhibit A to
Direct Agreement

The Finance Parties

Courtesy translation, not binding.

Exhibit B to
Direct Agreement
**Payment instructions
for Account**

Part V

Spot Capacity Agreement

This Spot Capacity Agreement (the “**Spot Capacity Agreement**”), is entered into between [User], a company incorporated and existing under the laws of [User’ State of incorporation], registered with the [User’s Registered Office] under number [registration number], tax code number [tax code number], whose principal office is located at [User’s address] (the “**User**”)²⁴ and **Terminale GNL Adriatico S.r.l.**, a company incorporated and existing under the laws of the Republic of Italy, registered with the Milan *Registro delle Imprese* under number 1788519, fiscal code/VAT code number 13289520150 and whose principal office is located at Piazza della Repubblica 14/16, 20124 Milan, Italy (“**Operating Company**”). Collectively, the User and the Operating Company are referred to herein as the “**Parties**”.

RECITALS

On 15 February 2010 the Operating Company has implemented an Regasification code (the “**Regasification Code**”) providing the conditions for access to the offshore regasification terminal owned by the Operating Company located approximately 17 km offshore Porto Levante, Italy,

On 12 May 2011 the Regasification Code has been approved by the Regulatory Authority for Electricity and Gas, by resolution Arg/Gas n° 57/11 pursuant to article 24, sub-section V, of the legislative decree no. 164/2000;

The Operating Company, pursuant to clause 2.3 of chapter II of the Regasification Code, has published on its Electronic Communication System: i) the Spot Capacity that is available for subscription, including the commencement date and duration of the Unloading Slot, the Scheduled Arrival Range, the Spot Redelivery Period, and the maximum volume of LNG that can be Unloaded during such Unloading Slot; and ii) the due date and time for submission of Access Requests for such Spot Capacity;

On [insert date] the User has submitted an Access Request for [Spot Capacity/Spot Capacity utilising Capacity Make-up]²⁵ including, *inter alia*, the information and statements specified in clause 2.4.6 (b) of chapter II of the Regasification Code.

NOW, THEREFORE, the User and the Operating Company agree to be legally bound as follows: (*TUTTO CIÒ PREMESSO E CONSIDERATO, l’Utilizzatore ed il Gestore concordano quanto segue:*)

1. Recitals and Definitions

1.1 The recitals are hereby incorporated and form an integral and essential part of this agreement.

1.2 All the capitalized terms used in the Spot Capacity Agreement shall have the same meaning given in clause 1.1 of chapter I of the Regasification Code.

2. Scope and duration

2.1 The Operating Company allocates to the User, and the User subscribes Spot Capacity for a volume of [insert volumes of LNG that will be unloaded during the Unloading Slot and in relation to

²⁴ It is understood that the Applicant shall only become a User upon, and as a consequence of, the acceptance of the Access Request by the Operating Company. Therefore, prior to completion of this Agreement, reference to the User in this Agreement shall be considered as a reference to the Applicant.

²⁵ Delete as appropriate.

Courtesy translation, not binding.

which the user requests the Service] cubic metres of LNG, with an indicative energy value in MJ of [insert indicative energy value of the LNG], for the Unloading Slot commencing on [insert the commencement date of the Unloading Slot posted on the Electronic Communication System] with a duration of [insert the duration of the Unloading Slot posted on the Electronic Communication System], and with the following Scheduled Arrival Range: [insert Schedule Arrival Range posted on the Electronic Communication System]. (Il Gestore conferisce all'Utilizzatore, e l'Utilizzatore sottoscrive, ...)

- 2.2 The Spot Redelivery Period will be the following: [insert Spot Redelivery Period posted by the Operating Company on the Electronic Communication System].
- 2.3 The Spot Redelivery Programme will be the one determined by the Operating Company in accordance with the provisions of the Regasification Code.
- 2.4 The Spot Capacity Agreement shall expire on [insert date corresponding to the ninetieth (90th) Day after the Annual Reconciliation for Inventory Loss and/or Gain as per paragraph (b) of clause 6.3 of Chapter III]. Expiration of this Spot Capacity Agreement shall be without prejudice to any obligations and/or liabilities which have accrued prior to the expiration date.

3. Charges

- 3.1 The Capacity Charge due by the User pursuant to this Spot Capacity Agreement shall be determined in accordance with the relevant provisions of the Regasification Code by applying the *Cqs*, the *CMr* for Spot Capacity as set forth in Schedule (1) hereto.
- 3.2 The Grid Capacity Charge and the Variable Transportation Charge due by the User pursuant to the Spot Capacity Agreement shall be determined in accordance with letters (d) and (e), respectively, of clause 8.1.1 of chapter III of the Regasification Code.
- 3.3 The Additional Charges and any other payments due by the User pursuant to the Spot Capacity Agreement shall be determined in accordance with the relevant provisions of the Regasification Code.
- 3.4 [The Operating Company shall apply the User's Capacity Make-Up Balance under the capacity agreement dated [date of relevant capacity agreement] for the payment of all or part of the Capacity Charge due pursuant to the Spot Capacity Agreement, in accordance with clause 8.10.2 of chapter III of the Regasification Code.]²⁶

4. Service Conditions

- 4.1 [User] states that it satisfies and will satisfy and maintain all of the Service Conditions provided in clause 2.3 of chapter III of the Regasification Code throughout the term of the Spot Capacity Agreement.
- 4.2 With particular reference to the Service Condition provided under letter (j) of clause 2.3 of chapter III, [User] acknowledges that the provision to the Operating Company of a duly executed authorisation to make requests for transactions at the System which imply the automatic acceptance of the User is essential in order for the Operating Company to be able to Redeliver the Gas. Therefore, [User] undertakes to provide the Operating Company with a duly executed copy of such authorization, as well as of any other documentation required by Snam Rete Gas in this respect, within two (2) Days from the execution of this agreement or, should such date fall later than the fifth (5th) Business Day preceding the date when the first Unloading is expected, immediately after the execution of this agreement.

²⁶ To be inserted if applicable.

Courtesy translation, not binding.

4.3 [User] hereby represents and warrants to the Operating Company that the Representations set forth in clauses 2.4.1 (a) through 2.4.1 (d) of chapter III of the Regasification Code are true and accurate as of the date on which the Spot Capacity Agreement is entered into. In respect of the Representations set forth in clauses 2.4.1 (a) and 2.4.1 (b) of chapter III of the Regasification Code, [User] undertakes that they will remain true and accurate as provided for in clauses 2.4.2 and 2.4.3 of chapter III of the Regasification Code.

5. Domicile election and notices

5.1 According to clause 4.2 of chapter I of the Regasification Code and for the purposes of the Spot Capacity Agreement, the User elects domicile at [insert address] in Milan, and undertakes to maintain such a domicile in Milan, for the entire duration of this Spot Capacity Agreement.

5.2 Any communication and notice to the User made by the Operating Company pursuant to clause 16 of chapter III of the Regasification Code, shall be sent at the address set out in article 5.1 above to the attention of Mr. [insert addressee], fax number [insert fax number], e-mail address [insert e-mail address].

6. Application of the Regasification Code

This Spot Capacity Agreement is subject to the terms and conditions of the Regasification Code, which are incorporated herein by reference.

[Place], [date]

[Applicant]

By: _____

Title: _____

The User, hereby, unconditionally approves, pursuant to and for the purposes of, articles 1341 and 1342 of the Italian Civil Code, the following clauses of the Regasification Code:

CHAPTER I:

4.1 “Competence of the Regulatory Authority for Electricity and Gas”; **4.2** “Submission to jurisdiction”; **4.3** “Arbitration of Technical Disputes”.

CHAPTER II:

2.1.1 “Provisional Terminal Capacity”; **2.4.2** “Subscription of Available Capacity”; **2.4.3** “Subscription of Spot Capacity”; **2.4.6** “Access Requests”; **2.4.8** “Execution of Modified Acceptances”; **2.5** “Access Denial”; **2.6** “Released Capacity”; **2.7** “Subscribed Non-Foundation Capacity to be made available to the Operating Company for allocation to third parties pursuant to article 11, sub section 3, of AEEG Resolution no 167 of 1 August 2005”; **2.8** “Subscribed Foundation Capacity to be made available to the Operating Company for allocation to third parties pursuant to article 6, sub section 3, of the MAP decree of 11 April 2006”; **3.2** “Annual Scheduling”; **3.3** “Three (3) Month Scheduling”; **3.7** “Unloading Slot unavailability”.

CHAPTER III:

2.2 “Parties’ obligations”; **2.6** “User’s standard of performance”; **2.7** “Refusal of changes in the Service”; **2.9** “Performance of the Redelivery Service”; **3** “Withdrawal from and duration of

Courtesy translation, not binding.

capacity agreements; 4 “Title”; 5.1.3 “Determination of quantity and quality of LNG at the Delivery Point”; 5.1.7 “User’s liability in relation to Unloading of Off-Spec LNG”; 6.1 “Redelivery of Gas”; 6.2 “Losses and Consumptions”; 7 “Force Majeure”; 8.1 “Invoicing by the Operating Company”; 8.4 “Suspension of payment of invoices”; 8.6 “Adjustment of Errors”; 8.7 “No deduction of taxes; liability for Maritime Charges”; 8.10 “Capacity Make-Up”; 8.11 “Charges for scheduling variance applicable to Continuous Users”; 8.12 “Charges for scheduling variance applicable to Spot Capacity”; 9 “Taxes, duties and charges on the Gas”; 12 “Exchanges of Subscribed Capacity”; 13 “Termination”; 14 “Liability”; 15 “Complaints”; 19 “Enforcement Costs”; 20 “Waiver of immunity”.

CHAPTER IV:

1.3 “Rejection of LNG Tankers”; 1.4.2 “Failure to make necessary modifications”; 3.6 “Re-Assignment of Berth”; 3.8.2 “Demurrage”; 3.9 “Excess of boil-off”.

CHAPTER VI:

2.1 “Subjects entitled to submit requests for the amendment of the Regasification Code”; 2.2 “Requirements for the admissibility of the requests”; 2.4 “Assessment of the request”; 4 “Communications”.

ANNEX (a):

Instructions for entering Non-Foundation and Spot Capacity Agreements: 2.3 “Irrevocability”; 4.2; 4.3;

Part I – Form of Access Request for all Capacity Agreements other than for any Foundation Capacity Agreement: **paragraph after letter (g)**;

Part II – Form Access Request for Capacity Make-up: **paragraph after letter (g)**;

Part III – Form of Modified Acceptance for Non-Foundation Capacity Agreement: **third paragraph**;

Part IV – Non-Foundation Capacity Agreement: clause 5 “Domicile election and notices”; clause 6 “Financing of the Terminal”.

Schedule (2) - Direct Agreement: Recital E; clause 2 “Consent to assignment and Step-In Rights”; clause 3 “Payments under the Capacity Agreement”; clause 6.7 “Arbitration”; clause 6.9 “Termination”; clause 6.10 “Conflicts of documents”.

Part V – Spot Capacity Agreement: clause 5 “Domicile election and notices”

ANNEX (e) – Form of Release Declaration: **last paragraph**.

[Note: the list of “unfair terms” (“*clausole vessatorie*”) shall be modified or integrated in accordance with the amendments to the Regasification Code (if any) required by the Regulatory Authority for Electricity and Gas].

[Applicant]

By: _____

Title: _____

Courtesy translation, not binding.

For Acceptance:

Terminale GNL Adriatico S.r.l.

By: _____

Title: _____

Courtesy translation, not binding.

Schedule (1)

[User to insert Schedule (1) as published by the Operating Company on the Electronic Communication System, with respect to the capacity which is the object of the Spot Capacity Agreement.]

Annex (b)

Part I

Form of undertaking to issue a First Demand Guarantee

[LETTERHEAD OF THE APPROVED ISSUING INSTITUTION]

[Place], [date]

To:
Terminale GNL Adriatico S.r.l. ("Operating Company")
Piazza della Repubblica 14/16
20124 Milan
Italy

For the attention of Capacity Subscription Coordinator

Sirs,

UNDERTAKING TO ISSUE A FIRST DEMAND GUARANTEE

Access Request dated [insert date]

We refer to the [name of the Applicant]'s (the "**Applicant**") Access Request attached hereto as Annex 1 (the "**Access Request**") which the Applicant wishes to submit to the Operating Company pursuant to the Regasification Code providing the conditions for access to the offshore regasification terminal owned by the Operating Company located approximately 17 km offshore Porto Levante, Italy, pursuant to article 24, sub-section V of the legislative decree no. 164/2000 (the "**Regasification Code**"). Under the provisions of the Regasification Code, upon submission of the Access Request the Applicant must, *inter alia*, provide to the Operating Company an irrevocable and unconditional undertaking from an Approved Issuing Institution (as defined in the Regasification Code) to issue a first demand guarantee in the form and under the circumstances as set forth therein.

We have received a copy of the Regasification Code and we acknowledge that, pursuant to the Regasification Code, the Applicant may enter into a Capacity Agreement (as defined in the Regasification Code) with the Operating Company for the performance by the Operating Company of the Service (as defined in the Regasification Code) with respect to the amount of [**Foundation Capacity/Non-Foundation Capacity/Spot Capacity**]²⁷ subscribed by the Applicant thereunder, in accordance with the provisions of such Capacity Agreement, and as such become a User (as defined in the Regasification Code) (the "**Agreement**").

(a) We represent that [name of the Approved Issuing Institution] is an Approved Issuing Institution as defined in the Regasification Code.

(b) If the Applicant becomes a User, we [name of the Approved Issuing Institution] (the "**Guarantor**"), hereby irrevocably and unconditionally undertake to promptly issue a first demand guarantee in the form set out in Part II of Annex (b) of the Regasification Code (the "**First Demand Guarantee**").

(c) The aggregate maximum amount payable pursuant to the Guarantee will not exceed Euro [insert the amount calculated pursuant to the formula set forth in clause 2 of Part II of Annex (b) on the basis of the amount of Terminal Capacity that forms the object of the Access Request].

²⁷ Delete as appropriate.

Courtesy translation, not binding.

- (d) This undertaking is governed by and construed in accordance with the laws of Italy.
- (e) Any dispute arising out of or in connection with this undertaking shall be subject to the Italian jurisdiction and to the exclusive competence of the Courts of Milan. For the purpose of proceedings (including for the purpose of receiving service of process), the Guarantor elects domicile in Milan at the following address [•].

[*Guarantor*]

By:
Title:

The Guarantor, hereby, unconditionally approves, pursuant to and for the purposes of, articles 1341 and 1342 of the Italian Civil Code, the following clauses of this First Demand Guarantee:

- letter (b);
- letter (e).

By:
Title:

Part II

Form of First Demand Guarantee

[LETTERHEAD OF THE APPROVED ISSUING INSTITUTION]

[Place], [date]

To:
Terminale GNL Adriatico S.r.l. (“Operating Company”)
Piazza della Repubblica 14/16
20124 Milan
Italy

For the attention of Capacity Subscription Coordinator

Sirs,

FIRST DEMAND GUARANTEE

Whereas:

- (a) We have been informed that on 15 February 2010 the Operating Company has implemented an Regasification Code providing the conditions for access to the offshore regasification terminal owned by the Operating Company located approximately 17 km offshore Porto Levante, Italy, pursuant to article 24, sub-section V of the legislative decree no. 164/2000 (the “**Regasification Code**”);
- (b) We have been informed that on [insert date], [insert name of the User] with registered office at [insert address], (the “**User**”) has entered into a Capacity Agreement (as defined in the Regasification Code) with the Operating Company for the performance by the Operating Company of the Service (as defined in the Regasification Code) with respect to the amount of [**Foundation Capacity/Non-Foundation Capacity/Spot Capacity**]²⁸ subscribed by the User thereunder, in accordance with the provisions of such Capacity Agreement (the “**Agreement**”);
- (c) The Regasification Code is an integral part of, and shall apply to, such Agreement; and
- (d) This Guarantee (as herebelow defined) is issued in accordance with the Agreement.

In this Guarantee words and expressions not otherwise defined herein shall have the same meaning as are respectively assigned to them in the Agreement.

Now the undersigned [insert name of the Approved Issuing Institution] (hereinafter the “**Guarantor**”; the Guarantor and the Operating Company being the “**Parties**”, and each of them a “**Party**”) hereby irrevocably and unconditionally undertakes as follows (the “**Guarantee**”):

1. The Guarantor hereby irrevocably guarantees to pay to the Operating Company, up to the Amount (as herebelow defined), any and all amounts due by the User as Regasification Service Charge and

²⁸ Delete as appropriate.

Courtesy translation, not binding.

Redelivery Service Costs pursuant to the Agreement, which have not been paid by the User on the respective due date (the “**Guaranteed Obligations**”), upon the Operating Company’s first demand (any such demand being referred to as a “**Demand**”). Any Demand shall be a demand for payment made in writing by the Operating Company to the Guarantor (with a copy sent to the User) in accordance with the form of Appendix A hereto attached, stating that any amounts due by the User pursuant to the Agreement and the Regasification Code has not been paid by the User to the Operating Company by the respective due date. The Guarantor shall pay the amounts indicated in the relevant Demand to the Operating Company (i) no earlier than 10 (ten) Business Days after receipt of evidence from the Operating Company that the relevant Demand has been notified to the User by registered post (*raccomandata con avviso di ricevimento*) pursuant to Section 12 below; and (ii) no later than 15 (fifteen) Business Days after receipt of the evidence specified in point (i) above.

2. For the first year of effectiveness of this Guarantee the aggregate maximum amount payable by the Guarantor hereunder (the “**Amount**”) shall be equal to Euro [●]²⁹.

Without prejudice to the right of the Guarantor to terminate this Guarantee pursuant to Section 4 below, if the effectiveness of this Guarantee is extended pursuant to Section 4, the Amount applicable during the relevant Extended Period shall be determined as follows: the User shall, at least forty (40) days before the Stated Expiration Date or the New Expiration Date (as applicable), notify to the Guarantor, with a copy to the Operating Company, the Amount that will apply during such Extended Period determined pursuant to Appendix B hereto attached.

Payment shall be made in favour of the Operating Company to such account as specified in the relevant Demand.

²⁹ Insert the amount calculated in accordance with the following formula:

$$I = \frac{(Cqs + CMr \times SC) + GCC + VTC}{n}$$

Where:

n=1

- In the case of a guarantee issued pursuant to a Contract for Spot Capacity or in the case of a guarantee issued pursuant to a Contract for Foundation or Non-Foundation Capacity related to one Unloading Slot

n=2

- In the case of a guarantee issued pursuant to a Contract for Foundation or Non-Foundation Capacity related to two Unloading Slots

n=3

- In the case of a guarantee issued pursuant to a Contract for Foundation or Non-Foundation Capacity related to three or more Unloading Slots

I	=	the amount;
Cqs	=	the <i>Cqs</i> applicable with respect to the relevant Thermal Year or period;
CMr	=	the <i>CMr</i> applicable with respect to the relevant Thermal Year or period;
SC	=	the amount of Subscribed Capacity under the relevant Capacity Agreement with respect to the relevant Thermal Year or period;
GCC	=	the User’s proportionate share of the total Grid Capacity Charge with respect to the relevant Thermal Year or period;
VTC	=	the User’s proportionate share of the total Variable Transportation Charge with respect to the relevant Thermal Year or period.

Courtesy translation, not binding.

3. The liability of the Guarantor shall not be impaired, reduced or affected by reason of any of the following (whether or not the Guarantor has notice thereof or has consented thereto):
 - (a) any time being given to the User or any forbearance or forgiveness under the Agreement by the Operating Company or any delay on the part of the Operating Company in asserting any of its rights against the User; or
 - (b) any disability, incapacity, change in ownership or change in status of the User; or
 - (c) any event of liquidation, bankruptcy, insolvency proceedings or similar proceedings or a change in the constitution of the User; or
 - (d) any other bond, security or guarantee held by the Operating Company for any of the obligations of the User under the Agreement or by any failure or delay by the Operating Company to enforce such bond, security or guarantee or by the release or waiver of such bond, security or guarantee by the Operating Company whether in whole or in part; provided however that under no circumstance whatsoever shall the Operating Company make a Demand in accordance hereunder with reference to any amount due pursuant to the Agreement which has been paid to the Operating Company under any such other bond, security or guarantee; or
 - (e) any invalidity, illegality or unenforceability of the Agreement or of any provision thereof.
4. This Guarantee shall come into force immediately at the date above written (the “**Effective Date**”) and shall be effective until the date falling on the first anniversary of the Effective Date (the “**Stated Expiration Date**”), provided however that the effectiveness of this Guarantee shall be automatically extended for further consecutive periods of one (1) year each (each such period an “**Extended Period**”) unless, at least thirty (30) days prior to the Stated Expiration Date or to the date falling on any consecutive anniversary thereof (the “**New Expiration Date**”), as the case may be, the Guarantor notifies in writing the Operating Company, pursuant to Section 12 below, that this Guarantee shall have to be deemed as terminated on the Stated Expiration Date or the New Expiration Date, as the case may be.
5. The Guarantor represents to the Operating Company that as at the date of this Guarantee:
 - (a) the execution and delivery of this Guarantee and the performance of all transactions and obligations contemplated hereby are within its corporate authority, and the execution, delivery and performance hereof have been duly authorised by all necessary proceedings;
 - (b) it is a bank or other institution whose long term unsecured and unguaranteed debt has a rating which matches or is higher than any two or more of the following ratings given by the following rating agencies:
 - (i) BBB+ by S&P;
 - (ii) Baa1 by Moody's; and/or
 - (iii) BBB+ by Fitch Ratings; and
 - (c) this Guarantee constitutes valid and legally binding obligations of the Guarantor enforceable in accordance with its terms.
6. The Guarantor agrees that this Guarantee shall be additional to and not in substitution for any rights or remedies that the Operating Company may have against the User under the Agreement or

Courtesy translation, not binding.

at law.

7. In case of any delay in the payment of the Guaranteed Obligations, the Guarantor shall pay to the Operating Company default interest on and subject to the same terms of the Regasification Code.
8. Any release, discharge or settlement between the Guarantor and the Operating Company shall be conditional upon no security, disposition or payment to the Operating Company being avoided, set aside or ordered to be refunded pursuant to any enactment or law relating to bankruptcy, liquidation, administration or insolvency or for any other reason whatsoever and, should this condition not be fulfilled, the Operating Company shall be entitled to enforce this Guarantee subsequently as if such release, discharge or settlement had not occurred and any payment had not been made.
9. No failure or delay by the Operating Company in exercising any right or remedy under this Guarantee shall operate as a waiver, nor shall any single or partial exercise or waiver of any right or remedy under this Guarantee preclude its further exercise or the exercise of any other right or remedy, respectively.
10. The Guarantor hereby irrevocably waives any right and benefits provided for under Articles 1944, 1945, 1955 and 1957 of the Italian civil code. Each of the provisions of this Guarantee is severable and distinct from the others, and if at any time any such provision is or becomes ineffective, inoperable, invalid or unenforceable it shall be severed and deemed to be deleted from this Guarantee, and in such event the remaining provisions of this Guarantee shall continue to have full force and effect.
11. This Guarantee is for the benefit of the Operating Company and its successors, transferees and assignees in connection with the Agreement.
12. (A) Any notice or other communication to be given (i) by one Party to the other Party and/or the User, or (ii) by the User to one or both the Parties, under, or in connection with, this Guarantee shall be in writing and signed by or on behalf of the Party giving it or the User, as the case may be. It shall be served by sending it by fax to the number set out in Section 12 (B), or sending it by pre-paid recorded delivery, special delivery or registered post, to the address(es) set out in Section 12 (B) and in each case marked for the attention of the relevant recipient set out in Section 12 (B) (or as otherwise notified from time to time in accordance with the provisions of this Section 12). Any notice so served by fax or post shall be deemed to have been duly given:
 - (a) in the case of fax, at the time of transmission as indicated in the transmission report; or
 - (b) in the case of prepaid recorded delivery, special delivery or registered post, at the date indicated in the receipt of delivery,

provided that in each case where delivery by hand or by fax occurs after 6pm on a Business Day or on a day which is not a Business Day, service shall be deemed to occur at 9am on the following Business Day.

Any references to time in this article are to local time in the country of the addressee.

(B) The addresses and fax numbers of the Parties and the User for the purpose of Section 12 (A) are as follows:

Operating Company

Terminale GNL Adriatico S.r.l.

Courtesy translation, not binding.

Address: Piazza della Repubblica 14/16 - 10124 Milano
Tel.: +39 02636981
Fax: +39 02.63698222
For the attention of: [_____]

[Guarantor]

Address:
Tel.:
Fax:
For the attention of:

[User]

Address:
Tel.:
Fax:
For the attention of:

(C) A Party may notify the other Party and the User, and the User may notify the Parties, of a change to its name, relevant addressee, address or fax number for the purposes of this Section 12, provided that, such notice shall only be effective on:

- (a) the date specified in the notice as the date on which the change is to take place; or
- (b) if no date is specified or the date specified is less than five (5) Business Days after the date on which notice is given, the date following ten (10) Business Days after notice of any change has been given.

13. This Guarantee, including any Demand hereunder, shall be governed by and construed in accordance with the laws of Italy and any dispute arising out of or in connection with this Guarantee shall be subject to the Italian jurisdiction and to the exclusive competence of the Courts of Milan. For the purpose of proceedings (including for the purpose of receiving service of process), the Guarantor elects domicile in Milan at the following address [*insert address*].

Yours faithfully,

(The Guarantor)

The Guarantor, hereby, unconditionally approves, pursuant to and for the purposes of, articles 1341 and 1342 of the Italian Civil Code, the following clauses of this First Demand Guarantee:

- article 1;
- article 3;
- article 4;
- article 6 ;
- article 8;
- article 9 ;
- article 10 ; and
- article 13

By:

Courtesy translation, not binding.

Title:

Courtesy translation, not binding.

Appendix A
Form of Demand

[Place],[date]

To: [Guarantor]
For the attention of: [●]

C.c.: [User]
For the attention of: [●]

Sirs,

Demand under the Guarantee dated [●] issued in favour of Terminale GNL Adriatico S.r.l.

We refer to the Guarantee issued by [●] for a maximum amount of Euro [●]³⁰ in our favour (the “Guarantee”).

We hereby demand payment of Euro [●]³¹ under the Guarantee and we hereby certify that:

1. This Demand is made in accordance with the Guarantee.
2. The amount demanded by this Demand was due by the User on [●] under art. [●] of the Regasification Code, but it has remained unpaid as of the date hereof, as a result of which the User is in breach of its obligations to pay under said art. [●] of the Regasification Code.
3. Payment should be made by telegraphic transfer to the following account:

Name: _____
Account No: _____
Sort Code: _____
Bank: _____
Address of Bank: _____

4. Words and expressions not defined in this Demand shall have the same meaning as are respectively assigned to them in the Guarantee.

We attach hereto a copy of the invoice sent to the User relating to the amount demanded by this Demand.

Yours faithfully,

(Terminale GNL Adriatico S.r.l.)

Att.

³⁰ Insert the Amount.

³¹ Insert amount of demand.

Appendix B

Form of notification of the Amount

[Place], [date]

To: [Guarantor]
For the attention of: [●]

C.c.: Terminale GNL Adriatico S.r.l.
For the attention of: Capacity Subscription Coordinator

Sirs,

Notification of the Amount applicable under the Guarantee dated [●] issued in favour of Terminale GNL Adriatico S.r.l. in case of extension of the Guarantee pursuant to Section 4 thereof

Pursuant to Section 2, second paragraph of the Guarantee, we hereby notify you that the Amount that would apply during the next Extended Period is equal to Euro [●]³².

Yours faithfully,

([User])

³²Insert the amount calculated in accordance with the following formula:

$$I = \frac{(Cqs + CMr \times SC) + GCC + VTC}{n}$$

Where:

n=1

- In the case of a guarantee issued pursuant to a Contract for Spot Capacity or in the case of a guarantee issued pursuant to a Contract for Foundation or Non-Foundation Capacity related to one Unloading Slot

n=2

- In the case of a guarantee issued pursuant to a Contract for Foundation or Non-Foundation Capacity related to two Unloading Slots

n=3

- In the case of a guarantee issued pursuant to a Contract for Foundation or Non-Foundation Capacity related to three or more Unloading Slots

I = the amount;

Cqs = the Cqs applicable with respect to the relevant Thermal Year or period;

CMr = il CMr applicabile con riferimento all'Anno Termico o periodo rilevante

SC = the amount of Subscribed Capacity under the relevant Capacity Agreement with respect to the relevant Thermal Year or period;

GCC = the User's proportionate share of the total Grid Capacity Charge with respect to the relevant Thermal Year or period;

VTC = the User's proportionate share of the total Variable Transportation Charge with respect to the relevant Thermal Year or period.

Courtesy translation, not binding.

Annex (c)

Form of First Demand Parent Company Guarantee

[LETTERHEAD OF THE PARENT COMPANY]

[Place], [date]

To:
Terminale GNL Adriatico S.r.l. ("Operating Company")
Piazza della Repubblica 14/16
20124 Milan
Italy

For the attention of Capacity Subscription Coordinator

Sirs,

FIRST DEMAND PARENT COMPANY GUARANTEE

Access Request dated [●]³³

We refer to the [Applicant]'s (the "**Applicant**") access request attached hereto as Annex 1 (the "**Access Request**") which the Applicant wishes to submit to the Operating Company pursuant to the Regasification code (the "**Regasification Code**") providing the conditions for access to the offshore regasification terminal owned by the Operating Company located approximately 17 km offshore Porto Levante, Italy, pursuant to article 24, sub-section V of the legislative decree no. 164/2000. Under the Regasification Code, the Applicant must, *inter alia*, provide to the Operating Company a First Demand Parent Company Guarantee in the form and under the circumstances as set forth therein. [Parent Company] (the "**Guarantor**") is a company that controls the Applicant pursuant to and for all legal purposes of article 2359, sub-section I, number (1) of the Italian Civil Code.][*This last statement should be omitted if paragraph (c) of clause 10.1 of chapter III applies. If this is the case, the definition of "Guarantor" should be inserted in paragraph (a) below*]

We have received a copy of the Regasification Code and we acknowledge that, pursuant to the Regasification Code, the Applicant may enter into an agreement with the Operating Company, and as such become a "User" (as defined in the Regasification Code), in relation to the Service for the [Foundation Capacity/Non-Foundation Capacity/Spot Capacity]³⁴, which the Operating Company shall provide to such User in accordance with the provisions of the Regasification Code, starting from the date, for the quantities, for the duration and on the terms and conditions indicated in such agreement (the "**Agreement**").

- (a) If the Applicant becomes a User, the Guarantor, hereby irrevocably and unconditionally:
- (i) guarantees to the Operating Company the due and punctual observance and performance of all payment obligations on the part of the User contained in or pursuant to the Agreement (including, without limitation, any obligation to pay the

³³ Note: in the event that this First Demand Parent Company Guarantee is issued after Applicant has become a User, references to "Applicant" shall be to "User," references to "Access Request" shall be to "Agreement," and all other modifications necessary to reflect the different status of the party for whom the guarantee is being provided shall be made.

³⁴ Delete as appropriate.

Courtesy translation, not binding.

Operating Company any damages, indemnity or other sums arising from the Agreement) (the "**Guaranteed Obligations**"); and

- (ii) agrees to the Operating Company to pay, as if it was the principal obligor, on first demand by the Operating Company, any sum or sums of money due under or pursuant to the Agreement (including, without limitation, any damages, indemnity or other sums due under or arising from the Agreement) but which has not been paid at the time such demand is made.
- (b) This is a guarantee of all the Guaranteed Obligations, but the Guarantor's liability under this guarantee in aggregate shall not exceed Euro [●] (the "**Amount**").³⁵
 - (c) This guarantee shall be effective from its execution and shall be in force and effect until the earliest of the following events, at which point in time the obligations of the Guarantor shall terminate:
 - (i) the time at which the Guaranteed Obligations have been unconditionally and irrevocably paid and discharged in full; or
 - (ii) unconditional and irrevocable payment by the Guarantor under this guarantee of a sum in aggregate not less than the Amount.
 - (d) The guarantee herein shall constitute and be a continuing guarantee notwithstanding any settlement of account or other matter or thing whatsoever, and in particular but without limitation, shall not be considered satisfied by an intermediate payment, intermediate discharge or intermediate satisfaction (in whole or in part) of the Guaranteed Obligations and shall extend to the ultimate balance and final fulfillment of all the Guaranteed Obligations.
 - (e) The Guarantor waives any right it may have of first requiring under article 1944 of the Italian Civil Code and any rights to raise any counterclaim related to any circumstance, act, omission, matter or thing - including the effectiveness of the Guaranteed Obligations - which but for this provision might operate to release or otherwise exonerate the Guarantor from its obligations hereunder in whole or in part. The Guarantor also waives any benefit, rights, claims or counterclaim pursuant to articles 1944, 1945, 1955 and 1957 of the Italian Civil Code.
 - (f) In case of any delay in the payment of the Guaranteed Obligations, the Guarantor shall pay to the Operating Company default interest on and subject to the same terms of the Regasification Code.
 - (g) If the Guaranteed Obligations are invalid or ineffective or any amount paid to the Operating Company to discharge any of the Guaranteed Obligations is capable of being avoided or clawed back, then this guarantee will also guarantee the obligations of the User to reimburse the Operating Company of the amounts made available to the User. Therefore, the Guarantor irrevocably and unconditionally undertakes to reimburse to the Operating Company any amount due to the Operating Company in case of invalidity or ineffectiveness of any of the Guaranteed Obligations or in case of claw-back or ineffectiveness of any payment made to discharge any of the Guaranteed Obligations.
 - (h) The Guarantor irrevocably and unconditionally waives, in the interest of the Operating Company, any right of recourse (*regresso*) pursuant to articles 1950 and 1951 of the Italian Civil Code or subrogation (*surrogazione*) pursuant to article 1949 of the Italian Civil Code or similar rights that it might be entitled to against the User until all amounts payable by the User under or in connection with the Agreement have been irrevocably paid and discharged in full.

³⁵ The Amount shall be equal to any and all amounts due by the User as Regasification Service Charge and Redelivery Service Costs pursuant to the Agreement, which have not been paid by the User on the respective due date, upon the Operating Company's first demand.

Courtesy translation, not binding.

- (i) This guarantee is in addition to and is not in anyway prejudiced by any other guarantee or security now or subsequently held by the Operating Company.
- (j) In case of any liquidation, bankruptcy, insolvency proceedings or similar proceedings of the User, this guarantee shall remain in full force and effect and in case of early termination of the Agreement or withdrawal by the Operating Company for any reason this guarantee will be immediately enforceable.
- (k) This guarantee is for the benefit of the Operating Company and its successors, transferees and assignees in connection with the Agreement.
- (l) This guarantee is governed by and construed in accordance with the laws of Italy.
- (m) Any dispute arising out of or in connection with this guarantee, shall be subject to the Italian jurisdiction and to the exclusive competence of the Courts of Milan. For the purpose of proceedings (including for the purpose of receiving service of process), the Guarantor elects domicile in Milan at the following address [•].

[Parent Company]

By:

Title:

The Guarantor, hereby, unconditionally approves, pursuant to and for the purposes of, articles 1341 and 1342 of the Italian Civil Code, the following clauses of this First Demand Guarantee:

- letter (a);
- letter (d);
- letter (e);
- letter (g);
- letter (h);
- letter (i);
- letter (j); and
- letter (m).

By:

Title:

Annex (d)

Requirements for the Terminal Insurance Policy and User Insurance Policy

Terminal Insurance Policy

The Operating Company shall carry third party liability insurance coverage in an amount no less than twenty-five million euros (€25,000,000) covering the Operating Company's legal liabilities for injury and property damage resulting from its operation of the Terminal.

User Insurance Policies

User shall ensure that all LNG Tankers must maintain adequate additional insurance cover as follows:

- (a) Wreck Removal Insurance; and
- (b) Protection and Indemnity (P&I) Insurance in the maximum amount available from a recognised P&I Club in the International Group of P&I Clubs (including coverage for the LNG Tanker's legal liabilities for damage to the Terminal, spills/pollution, and other third party injury and property damage).

User shall also carry third party liability insurance coverage in an amount no less than twenty-five million euros (€25,000,000) covering User's legal liabilities for injury and property damage resulting from its use of the Terminal.

Courtesy translation, not binding.

Annex (e)

Form of Release Declaration

[LETTERHEAD OF THE USER]

[Place], [date]

To:
Terminale GNL Adriatico S.r.l. (“Operating Company”)
Piazza della Repubblica 14/16
20124 Milan
Italy

For the attention of Capacity Subscription Coordinator

Sirs,

RELEASE DECLARATION

[Foundation/Non-Foundation] Capacity Agreement dated *[insert date of execution of the Capacity Agreement]*

With reference to the **[Foundation/Non-Foundation] Capacity Agreement** dated *[insert date of execution of the Capacity Agreement]* and in accordance with the provisions of clause 2.6 (a) of chapter II of the Regasification Code, **[User]** hereby releases Subscribed **[Foundation/Non-Foundation] Capacity** as follows:

[use one row for each Unloading Slot being released]

Year and Month	Quantity of [Foundation/Non-Foundation] Released Capacity	Slot being released <i>[if available in Annual Unloading Schedule or Three (3) Month Schedule]</i>

[User] acknowledges and accepts that in accordance with clause 2.6 (b) of chapter II of the Regasification Code, it shall continue to be liable to pay to the Operating Company the Capacity Charge relating to the Subscribed **[Foundation/Non-Foundation] Capacity** hereby released, as long as and to the extent that one or more new Capacity Agreements have not been entered into in respect of such released capacity.

[User]

By: _____

Title: _____

Courtesy translation, not binding.

Annex (f)

Form of Reclaim Declaration

[LETTERHEAD OF THE USER]

[Place], [date]

To:
Terminale GNL Adriatico S.r.l. (“Operating Company”)
Piazza della Repubblica 14/16
20124 Milan
Italy

For the attention of Capacity Subscription Coordinator

Sirs,

RECLAIM DECLARATION

[Foundation/Non-Foundation] Capacity Agreement dated *[insert date of execution of the Capacity Agreement]*

Release Declaration dated *[insert date of execution of the Released Declaration]*

With reference to the **[Foundation/Non-Foundation] Capacity Agreement** dated *[insert date of execution of the Capacity Agreement]* and the Release Declaration dated *[insert date of execution of the Release Declaration]*, and in accordance with the provisions of clause 2.6 (c) of chapter II of the Regasification Code, *[User]* hereby requests to reclaim Released **[Foundation/Non-Foundation] Capacity** as follows:

[use one row for each Unloading Slot being reclaimed]

Year and Month	Quantity of [Foundation/Non-Foundation] Released Capacity	Slot being reclaimed <i>[if available in Annual Unloading Schedule or Three (3) Month Schedule]</i>

[User] hereby kindly requests that the Operating Company revises its Annual Unloading Schedule and its Three (3) Month Schedule accordingly.

[User]

By: _____

Title: _____

Annex (g)

Definition of and method for calculation of Net Present Value

"Net Present Value" means the net present value of any stream of cashflows calculated as at the effective date of withdrawal from or, as the case may be, termination of the relevant Capacity Agreement, and which is determined by:

- (i) discounting back to such effective date each stream of cashflows for each consecutive six Month period from the end of the term of the relevant Capacity Agreement to such effective date, at the Discount Rate prevailing at such effective date, starting from and including such period to such effective date; and
- (ii) aggregating all of the discounted cash flow streams produced pursuant to paragraph (i) above;

where:

"Discount Rate" means the discount rate for Italy published by the competition sector of the European Commission and available at:

http://ec.europa.eu/comm/competition/state_aid/legislation/reference_rates.html

or if such rate ceases to be available, such other equivalent rate that may be determined by the Operating Company, acting reasonably in the circumstances.

Annex (h)

Gas Quantity, Quality and Pressure Specifications

SECTION I –GAS QUANTITY

The quantity of Gas injected into the Grid will be expressed in energy units obtained as the product of the measured volume and Gross Heating Value. The quantities will be reported and expressed in units as required by the network code for the Grid.

SECTION II –GAS QUALITY

II.1 Physical Properties

Gas transmitted by the Operating Company to the Cavarzere Entry Point, shall have physical properties that fall within the acceptable ranges listed below:

- (a) Gross Heating Value, 34.95 - 45.28 MJ/Sm³;
- (b) Wobbe Index, 47.31 - 52.33 MJ/Sm³;
- (c) Relative density, 0.5548 – 0.8;
- (d) Water Dewpoint *, ≤ -5°C;
- (e) Hydrocarbon Dewpoint **, ≤ 0°C;
- (f) Maximum Temperature, ≤ 50° C.

* At the relative pressure of 70 bars gauge

** At the relative pressure of 1 to 70 bars gauge

The reference conditions for standard conditions are:

Pressure = 1.01325 bar

Temperature = 288.15 K (15°C)

II.2 Components

Gas transmitted by the Operating Company to the Cavarzere Entry Point, shall contain equal to or less than the acceptable values for the components and substances listed below:

- (a) Methane (C₁), (*) mol%;
- (b) Ethane (C₂), (*) mol%;
- (c) Propane (C₃), (*) mol%;
- (d) Butanes (C₄) and heavier, (*) mol%;
- (e) Pentanes (C₅) and heavier, (*) mol%;
- (f) Nitrogen (N₂), (*) mol%;
- (g) Carbon Dioxide (CO₂), 3 mol%;
- (h) Oxygen (O₂), 0.6 mol%;
- (i) Hydrogen Sulfide (H₂S), 6.6 mg/SCM;
- (j) Total sulphur content, 150 mg/SCM;
- (k) Mercaptans, 15.5 mg/SCM;

Courtesy translation, not binding.

* For these components, the acceptable values are intrinsically limited by the acceptability range of the Wobbe Index.

II.3 Other Properties

The Gas shall contain no traces of the following components:

- (a) Water and/or hydrocarbon in liquid state;
- (b) Solid particulates in such quantities that will damage the material used for transportation of the gas;
- (c) Other gases which may affect the safety or integrity of the transportation system.

SECTION III – GAS PRESSURE

The Gas will be delivered to the Cavarzere Entry Point below the maximum allowable operating pressure of the pipeline as governed by existing permits.

Annex (i)

LNG Quantity, Quality and Pressure Specifications

SECTION I – LNG QUANTITY

The quantity of LNG delivered by or on behalf of a User shall be calculated by the User following the procedures set for in Annex (j) and shall be verified by an independent surveyor agreed upon by User and Operating Company. Any BTUs of Gas provided to the User from the Terminal via the vapor return line in order to facilitate the unloading operation, shall be deducted from the BTU's delivered by User as LNG to determine the Net Unloaded LNG delivered.

SECTION II – LNG QUALITY

II.1 Gross Heating Value and Wobbe Index

LNG delivered by or on behalf of a User to the Operating Company at the Delivery Point, in a gaseous state, shall have a Gross Heating Value in the range of 34.95 MJ/Sm³ to 45.28 MJ/Sm³ and a Wobbe Index in the range of 47.31 MJ/Sm³ to 52.13 MJ/Sm³.

II.2 Components

LNG delivered by or on behalf of a User to the Operating Company at the Delivery Point, in a gaseous state, shall contain for the components and substances listed below, not more than the following:

- (a) Methane (C₁), (***) mol%
- (b) Ethane (C₂), (***) mol%;
- (c) Propane (C₃), (***) mol%;
- (d) Butanes (C₄) and heavier, (***) mol%;
- (e) Pentanes (C₅) and heavier, (***) mol%;
- (f) Nitrogen (N₂), (***) mol%;
- (g) Carbon Dioxide (CO₂), 0.05 mol%;
- (h) Oxygen (O₂), 0.05 mol%;
- (i) Hydrogen Sulfide (H₂S), 4.59 mg/SCM;
- (j) Total sulphur content, 45.88 mg/SCM;
- (k) Mercaptans, 9.18 mg/SCM;
- (l) Mercury, 10 Ng/SCM*;

And not exceed the following:

- (m) Hydrocarbons dew point: -5°C **; and
- (n) Cargo vapor pressure at Delivery Point: 140 millibars gauge.

The LNG shall not contain any liquid or solid contaminants.

* Mercury shall be measured in accordance with ASTM D-5954, in which the minimum mercury measurement possible with respect to LNG is 10 nanograms/ SCM (Ng/SCM) of

Courtesy translation, not binding.

Gas.

** In the range of pressure 1 to 70 bars gauge.

*** For these components, the acceptable values are intrinsically limited by the acceptability range of the Wobbe Index.

Annex (j)

Testing and Measuring Methods

This Annex (j), entitled "Testing and Measuring Methods", is attached to and forms a part of the Regasification Code and sets forth detailed procedures for sampling and analysing LNG, for gauging and calculating the density and heating value of LNG pursuant to clause 5 of chapter III of the Regasification Code and for determining the quality and quantity of Redelivered Gas.

SECTION I - DEFINITIONS

Terms defined in the main body of the Regasification Code and appearing in this Annex (j) are used herein as defined in the Regasification Code. Reference to GPA, ISO, or ASTM standards and procedures shall be to the latest officially published revisions thereof.

PART A - LNG TESTING AND MEASURING METHOD

SECTION II - TANK GAUGE TABLES

II.1 Calibration of LNG Tanks

Prior to the utilization of any LNG Tanker, User shall: (a) in the case of an LNG Tanker the tanks and volume measuring devices of which have never been calibrated, arrange for each LNG tank and volume measuring device of such LNG Tanker to be calibrated for volume against level by a qualified surveyor agreed by User and Operating Company, or (b) in the case of an LNG Tanker the tanks and volume measuring devices of which have previously been calibrated, furnish to Operating Company evidence of such calibration by a qualified surveyor and if required, arrange for the re-calibration of all tanks and volume measuring devices by a qualified surveyor agreed by User and Operating Company, subject paragraph (g) of clause 5.1.3 of chapter III.

II.2 Preparation of Tank Gauge Tables

User shall have a qualified surveyor prepare tank gauge tables for each LNG tank of each vessel which User intends to use as an LNG Tanker from the results of the calibration referred to in Section II.1 above. Such tank gauge tables shall include sounding tables, correction tables for list (heel) and trim, volume corrections to tank service temperature, and other corrections if necessary. The tank gauge tables prepared by such surveyor shall be verified for use by the relevant Classification Society for the LNG Tanker or by such party agreed between the Parties and available for inspection by Italian authorities.

II.3 Accuracy of Tank Gauge Tables

The tank gauge tables prepared pursuant to Section II.2 above shall indicate volumes in Cubic Meters expressed to the nearest thousandth, with tank depths expressed in meters to the nearest thousandth.

II.4 Witnessing of Tank Calibration

Operating Company shall have the right to have its representative witness the tank calibrations referred to in Section II.1 above. User shall give adequate advance notice to Operating Company of the timing of such tank calibrations.

II.5 Re-calibration of LNG Tanks in Case of Distortion, Reinforcement or Modification

In the event that any LNG tank of any LNG Tanker suffers distortion or undergoes reinforcement or modification of such a nature as to cause either User or Operating Company reasonably to question the validity of the tank gauge tables referred to in Section II.2 above, User shall arrange for such LNG tank to be re-calibrated in the same manner as set forth in Sections II.1 and II.2 hereof during any period when such LNG Tanker is out of service for inspection and/or repairs. User shall bear the costs of re-calibration unless such re-calibration was done at Operating Company's request and did not demonstrate any

Courtesy translation, not binding.

inaccuracy in the tank gauge tables, in which case the Operating Company shall pay the costs of re-calibration. Except as provided in this Section II.5, no other re-calibration of any LNG tank of any LNG Tanker shall be required.

SECTION III - SELECTION OF GAUGING DEVICES

III.1 Liquid Level Gauging Devices

III.1.1 Each LNG tank of each LNG Tanker shall be equipped with a main and an auxiliary liquid level gauging device each of a different measuring principle. A factory acceptance test for measurement accuracy of all liquid gauging devices shall be witnessed and approved by an Operating Company approved company. Such test results shall be furnished to Operating Company. This article applies to Article II.1(a) only.

III.1.2 The measurement accuracy of the main liquid level gauging devices shall be ± 7.5 millimetres and of the auxiliary liquid level gauging devices shall be ± 10 millimetres

III.1.3 The level in each LNG tank shall be logged or printed.

III.2 Temperature Gauging Devices

III.2.1 Each LNG tank of each LNG Tanker shall be equipped with a minimum of five (5) temperature gauging devices located on or near the vertical axis of such LNG tank. The temperature sensors shall be supported by spare sensors, for emergency use, which are mounted adjacent to the temperature sensors.

III.2.2 Two sensors including spares shall be installed at the tank bottom and the tank top, in order to constantly measure the temperatures of liquid and vapour respectively. The remaining sensors shall be installed at equally spaced distances between the tank bottom and top. All the sensors shall be mounted such that they are not affected by the spray of LNG when the spray pumps are in operation.

III.2.3 The measurement accuracy of the temperature gauging devices shall be as follows:

<u>Temp. Range, °C</u>	<u>Range, +/- °C</u>
-165 to -140	0.2
-140 to -120	0.3
-120 to +80	1.5

III.2.4 The temperatures in each LNG tank shall be logged or printed.

III.3 Pressure Gauging Devices

III.3.1 Each LNG tank of each LNG Tanker shall have one absolute pressure gauging device.

III.3.2 The measurement accuracy of the pressure gauging device shall be plus or minus one percent ($\pm 1\%$) of span. The maximum integrated accuracy of the system shall not exceed six (6) mbarA.

III.3.3 The pressure in each LNG tank shall be logged or printed.

III.4 Verification of Accuracy of Gauging Devices

Gauging devices shall be verified for accuracy, and any inaccuracy of a device exceeding the permissible tolerance shall require correction of recordings and computations in accordance with the terms of clause 5.1.3 (h) of chapter III of the Regasification Code.

SECTION IV - MEASUREMENT PROCEDURES

IV.1 Liquid Level

- IV.1.1 Measurement of the liquid level in each LNG tank of each LNG Tanker shall be made to the nearest millimetre by using the main liquid level gauging device referred to in Section III.1 hereof. Should the main device fail, the auxiliary device shall be used.
- IV.1.2 Five (5) readings shall be made in as rapid succession as possible. The arithmetic average of the readings shall be deemed the liquid level.

The supplier of the measuring equipment shall make sure that the CTMS is able to compensate for dynamic movement while the LNG Tanker is moored at the Terminal. The internal level sampling rate of the CTMS shall be fast enough to enable an appropriate processing, resulting in above specified readings with time intervals of typically 15 seconds to be stable within CTS accuracy limits. Such information must be included as part of the LNG Tanker calibration already approved by a qualified surveyor.³⁶

Any variation in the prescribed number of measurement readings that may be required to compensate for dynamic movement of the LNG Tanker while moored at the ALT terminal is to be provided by the supplier of the measuring equipment. Such information must be included as part of the LNG Tanker calibration tables already approved by a qualified surveyor.

- IV.1.3 Such arithmetic average shall be calculated to the nearest 0.1 millimetre and shall be rounded to the nearest millimetre.
- IV.1.4 The same liquid level gauging device must be used for both the initial and final measurements during loading. If the main level gauging device is inoperative at the time of commencement of loading, necessitating use of the auxiliary level gauging device, the auxiliary level gauging device shall be used at the time of cessation of loading, even if the main level gauging device has subsequently become operative. Trim and list of the LNG Tanker shall be kept unchanged while the referenced measurements are performed.

IV.2 Temperature

- IV.2.1 At the same time liquid level is measured, temperature shall be measured to the nearest zero decimal one degree Celsius (0.1°C) by using the temperature gauging devices referred to in Section III.2 hereof.
- IV.2.2 In order to determine the temperature of liquid and vapor in the tanks of an LNG Tanker, one (1) reading shall be taken at each temperature gauging device in each LNG tank. An arithmetic average of such readings with respect to vapor and liquid in all LNG tanks shall be deemed the final temperature of vapor and liquid.
- IV.2.3 Such arithmetic average shall be calculated to the nearest zero decimal zero one degree Celsius (0.01°C) and shall be rounded to the nearest zero decimal one degree Celsius (0.1°C).

IV.3 Pressure

- IV.3.1 At the same time liquid level is measured, the absolute pressure in each LNG tank shall be measured to the nearest one (1) mbarA by using the pressure gauging device referred to in Section III.3 hereof.
- IV.3.2 The determination of the absolute pressure in the LNG tanks of each LNG Tanker shall be made by taking one (1) reading of the pressure gauging device in each LNG tank, and then by taking an

³⁶ The methodology is still under development and testing.

Courtesy translation, not binding.

arithmetic average of all such readings.

- IV.3.3 Such arithmetic average shall be calculated to the nearest (0.1) mbarA and shall be rounded to the nearest one (1) mbarA.
- IV.3.4 In the event that LNG Tanker utilizes units other than mbarA, then Operating Company and User shall agree on the appropriate equivalent units to be employed.

IV.4 Procedures in Case of Gauging Device Failure

Should the measurements referred to in Sections IV.1, IV.2 and IV.3 hereof become impossible to perform due to a failure of gauging devices, alternative gauging procedures shall be determined by mutual agreement between Operating Company and User in consultation with the independent surveyor.

IV.5 Determination of Volume of LNG Unloaded

- IV.5.1 The list (heel) and trim of the LNG Tanker shall be measured at the same time as the liquid level and temperature of LNG in each LNG tank are measured. The LNG Tanker's cargo transfer piping shall contain hydrocarbons in the same state during final gauging as at initial gauging. Vapor lines that are connected to the vapor header shall be opened to ensure that the vapor pressure in all LNG tanks is equalized. Such measurements shall be made immediately before unloading commences and immediately after unloading is completed. The volume of LNG, stated in Cubic Meters to the nearest 0.001 Cubic Meter, shall be determined by using the tank gauge tables referred to in Section II hereof and by applying the volume corrections set forth therein.
- IV.5.2 The volume of LNG unloaded shall be determined by deducting the total volume of LNG in all tanks immediately after unloading is completed from the total volume in all tanks immediately before unloading commences. This volume of LNG unloaded is then rounded to the nearest Cubic Meter.

SECTION V - DETERMINATION OF COMPOSITION OF LNG

V.1 Sampling Procedures

- V.1.1 Representative samples of LNG shall be obtained continuously according to the method described in the latest version of the ISO 8943, at an even rate during the period starting immediately after a steady flow rate has been reached, the unloading line is full of liquid and continuous unloading has commenced and ending immediately prior to the suspension of continuous unloading.
- V.1.2 A composite gaseous sample shall be collected in a suitable gas holder using a continuous gasification/collection method agreed upon by User and Operating Company.
- V.1.3 Three (3) samples shall be transferred from the gas holder to sample bottles after completion of unloading. Such sample bottles shall be sealed by the surveyor who witnessed such sampling in accordance with clause 5.1.3 (e) of chapter III of the Regasification Code and shall be delivered to Operating Company. One (1) such sample shall be used for analysis to determine the composition.
- V.1.4 The gaseous samples taken at the Unloading Port shall be distributed as follows:

First sample:	for analysis by Operating Company.
Second sample:	for analysis by User.
Third sample:	for retention by Operating Company for at least forty five (45) days.

In case any dispute as to the accuracy of any analysis is raised, the sample shall be further retained until Operating Company and User agree to retain it no longer.

- V.1.5 Failure in Collecting Samples and in Determining the Composition of LNG.

Courtesy translation, not binding.

If sampling and/or analysis fails for some reason, the arithmetic average of the analysis results of the User's five (5) immediately preceding cargoes (or of the total cargoes delivered if less than five) under the Regasification Code from the Delivery Point shall be deemed to be the composition of the LNG at the Delivery Point. The unloaded BTU's and Metric Tons are calculated as follows:

$$\frac{\Sigma^5 (\text{BTU/m}^3) \times \text{Vm}^3 \text{ unloaded}}{5} = \text{BTU's}$$
$$\frac{\Sigma^5 (\text{Kg/m}^3) \times \text{Vm}^3 \text{ unloaded}}{5 \times 1000} = \text{Metric Tons}$$

It is understood that the BTU calculation above refers to the values of the Net Adjusted Unloaded LNG as defined in paragraph (g) of clause 5.1.3 of Chapter III

V.2 Analysis Procedures

- V.2.1 Hydrocarbons, Carbon Dioxide and Nitrogen – Operating Company's sample of unloaded LNG, shall be analyzed immediately by Operating Company to determine, by gas chromatography, the mol fraction of hydrocarbons, carbon dioxide and nitrogen in the sample. The method used shall be the method described in the latest version of the ISO 6974 or any other method agreed upon by Operating Company and User. Duplicate runs shall be made on each sample to determine that the repeatabilities of peak heights or peak areas are within acceptable limits. The calculated results of such duplicate runs shall be averaged.
- V.2.2 Sulphur, Mercaptans, Hydrogen Sulphide - The ISO 6326 shall be used to determine the sulphur compounds content of Operating Company's samples of unloaded LNG, unless User and Operating Company mutually agree that some other method should be used.
- V.2.3 Quality Determination – The results of the analysis under Section V.2.1 above shall be used with calculation methods in Annex (j) Section VI to determine if the LNG meets the quality specifications set forth in Annex (i) of the Regasification Code.

V.3 Correlation Test of Analytical Equipment and Devices

Operating Company and User shall perform a correlation test using standard gas in order properly to maintain the accuracy of User's and Operating Company's equipment and devices, prior to use and during periods of use. Such correlation tests are subject to the following conditions:

- (a) Mutual agreement of User and Operating Company as to timing of a test;
- (b) A standard gas sample shall be obtained by User;
- (c) The standard sample shall be transported to the Unloading Port on an LNG Tanker;
- (d) Operating Company shall analyze the sample and return it to User on an LNG Tanker;
- (e) User shall analyze the sample; and
- (f) The results of these tests shall be made available to User and Operating Company.

SECTION VI - DETERMINATION OF BTU QUANTITY OF LNG DELIVERED

VI.1 Calculation of Density

The density of LNG stated in kilograms per Cubic Meter shall be calculated in accordance with ISO 6578 – 91 by use of the formula:

$$D = \frac{\Sigma (X_i \times M_i)}{\Sigma (X_i \times V_i) - (K1 + (K2 - K1) \times X_n) \times X_m}$$

Courtesy translation, not binding.

$$\left\{ \frac{\text{-----}}{0.0425} \right\}$$

where:

- D is the density to four (4) significant figures of the LNG unloaded, stated in kilograms per Cubic Meter at temperature T_L ;
- T_L is the temperature of the LNG in the tanks of the LNG Tanker before unloading, stated in degrees Celsius to the nearest 0.1°C;
- X_i is the mol fraction, to the nearest fourth (4th) decimal place, of component (i) from the composition obtained in accordance with Section V hereof. The mol fraction of methane shall be adjusted so as to make the total mol fraction equal to 1.0000;
- M_i is the molecular weight of component (i) as set forth in Table 1 attached hereto;
- V_i is the molar volume, to the nearest sixth (6th) decimal place, of component (i), stated in Cubic Meters per kilogram-mol at temperature T_L and obtained by linear interpolation of the data set forth in Table 2 attached hereto;
- X_m is the mol fraction, to the nearest fourth (4th) decimal place, of methane from the composition obtained in accordance with Section V.2 hereof;
- X_n is the mol fraction, to the nearest fourth (4th) decimal place, of nitrogen from the composition obtained in accordance with Section V.2 hereof;
- K1 is the volume correction, to the nearest sixth (6th) decimal place, stated in Cubic Meters per kilogram-mol at temperature T_L and obtained by linear interpolation of the data set forth in Table 3 attached hereto; and
- K2 is the volume correction, to the nearest sixth (6th) decimal place, stated in Cubic Meters per kilogram-mol at temperature T_L and obtained by linear interpolation of the data set forth in Table 4 attached hereto.

VI.2 Calculation of Gross Heating Value

VI.2.1 The Gross Heating Value (mass basis) of LNG in MJ per kilogram shall be calculated by use of the formula:

$$H_m(t_1) = \frac{\sum [X_i \times H_{vi}(t_1)]}{\sum (X_i \times M_i)}$$

where:

- H_m is the Gross Heating Value of LNG, stated in MJ per kilogram;
 - H_{vi} is the Gross Heating Value of component (i), stated in KJ / mol as set forth in Table 1 attached hereto;
 - X_i is the mol fraction, to the nearest fourth (4th) decimal place, of component (i) from the composition obtained pursuant to Section V hereof. The mol fraction of methane shall be adjusted so as to make the total mol fraction equal to 1.0000; and
 - M_i is the molecular weight of component (i) as set forth in Table 1 attached hereto.
- VI.2.2 The Gross Heating Value (volume basis) for purposes of Annex (i) of the Regasification Code shall be calculated by use of the formula:

Courtesy translation, not binding.

$$H_v[t_1, V(t_2, p_2)] = \frac{101.325 \times \sum (X_i \times H_{vi} [t_1, V(t_2, p_2)])}{R \times 288.15 \times z_{mix} (t_2, p_2)}$$

where:

H_v is the Gross Heating Value, stated in MJ per SCM;

X_i is the mol fraction, to the nearest fourth (4th) decimal place, of component (i) from the composition obtained pursuant to Section V hereof. The mol fraction of methane shall be adjusted so as to make the total mol fraction equal to 1.0000;

$H_{vi} [t_1, V(t_2, p_2)]$ is the Gross Heating Value of component (i), stated in KJ / mol, as set forth in Table 1 attached hereto;

R is the molar gas constant = 8.314510 J per mol per K; and

$z_{mix} (t_2, p_2)$ is the compression factor under standard conditions calculated in accordance with:

$$z_{mix} (t_2, p_2) = 1 - (\sum X_i \times \sqrt{b_i})^2$$

where:

$\sqrt{b_i}$ is the summation factor of component (i) as set forth in Table 1 attached hereto.

VI.2.3 The Wobbe Index for the purposes of Annex (i) of the Regasification Code shall be calculated by use of the formula:

$$\text{Wobbe Index} = \frac{H_v[t_1, V(t_2, p_2)]}{\text{square root } \{[(\sum (X_i \times M_i)) / 28.9626] \times [0.99958 / z(t_2, p_2)]\}}$$

where:

Wobbe Index is the Gross Heating Value of LNG, stated in MJ per Standard Cubic Meter divided by the square root of the Specific Density. The Wobbe Index shall be rounded to the nearest hundredth (0.01) of a MJ/SCM;

H_v is the Gross Heating Value, stated in MJ per SCM, calculated and obtained in accordance with Section VI.2.2 hereof;

X_i is the mol fraction, to the nearest fourth (4th) decimal place, of component (i) from the composition obtained pursuant to Section V hereof. The mol fraction of methane shall be adjusted so as to make the total mol fraction equal to 1.0000;

M_i is the molecular weight of component (i) as set forth in Table 1 attached hereto; and

$z_{mix} (t_2, p_2)$ is the compression factor under standard conditions calculated in accordance with:

$$z_{mix} (t_2, p_2) = 1 - (\sum X_i \times \sqrt{b_i})^2$$

where:

$\sqrt{b_i}$ is the summation factor of component (i) as set forth in Table 1 attached hereto.

VI.3 Calculation of BTU Quantity of LNG Delivered

The BTU quantity of LNG delivered shall be computed by using the formula below and applying the method of rounding set forth in VI.4.1:

Courtesy translation, not binding.

$$Q = [(V \times D \times H_m / 1055.06) - Q_R - Q_F] \times (1-FCI)$$

where:

- Q is the BTU quantity delivered;
- V is the volume of the LNG unloaded, stated in Cubic Meters, obtained pursuant to Section IV.5 hereof;
- D is the density of the LNG, stated in kilograms per Cubic Meter, as calculated in accordance with Section VI.1 hereof;
- H_m is the Gross Heating Value of the LNG, stated in MJ per kilogram, as calculated in accordance with Section VI.2.1 hereof; and
- Q_R is the BTU quantity of the vapor which was displaced by the volume of the LNG unloaded (V). Q_R is computed by use of the formula:

$$Q_R = V \times \frac{288.15}{273.15 + T_V} \times \frac{P_a}{1013.25} \times \frac{35}{1055.06}$$

where:

- T_V is the temperature of the vapor in the tanks of the LNG Tanker after unloading, stated in degrees Celsius to the nearest zero decimal one (0.1) degree Celsius; and
- P_a is the absolute pressure of the vapor in the tanks of the LNG Tanker after unloading, stated in millibars to the nearest mBar; and
- 35 is the heating value of the vapor (assumed to be 94% of methane and 6% of nitrogen) stated in MJ per Cubic Meter for both combustion & metering references at 15 °C and 1013.25 millibars.
- Q_F is the equivalent amount in BTU of Boil-off gas consumed by the LNG Tanker as fuel during the discharge. Q_F is computed by use of the formula:

$$Q_F = VF \times \frac{35 \text{ (or 50)}}{1055.06}$$

where:

- VF is the amount of Boil-off gas consumed by the LNG Tanker as fuel and expressed in standard cubic meters or kilograms depending on the type of meter installed on the LNG Tanker.
- 35 is the heating value of Boil-off gas (assumed to be 94% for methane and 6% for nitrogen), expressed in MJ / standard cubic meter for combustion values and assay at 15 ° C and 1013, 25 millibars.
- 50 is the calorific value of Boil-off gas (assumed to be 94% for methane and 6% for nitrogen), expressed in MJ / kg for combustion values and assay at 15 ° C and 1013.25 millibars.

If it is not possible to measure the amount of Boil-off gas consumed during the discharge, it will be considered a number of BTU of Boil-off gas consumption amounted to 1620 MMBTU.

FCI is the Correction Factor for the Uncertainty inventory's Loss and/or Gain and has the meaning given in clause 6.3 of Chapter III.

Courtesy translation, not binding.

The Parties agree that should it be possible to measure the composition of the return vapor and that the resultant heating value is shown to be significantly different from the value stated above for a period of not less than six (6) months, the Parties will meet in good faith to discuss a revision to the assumed heating value for return vapor which would be applicable thereafter.

VI.4 Method of Rounding Numbers

VI.4.1 General:

If the first of the figures to be discarded is five (5) or more, the last of the figures to be retained is increased by one (1).

If the first of the figures to be discarded is four (4) or less, the last of the figures to be retained is unaltered.

For the purpose of rounding to a zero (0), the last of the figures to be retained shall have the same value as a ten (10).

The following examples are given to illustrate how a number is to be established in accordance with the above:

<u>Number to be rounded</u>	<u>Number After Being Rounded to First Decimal Place</u>
2.24	2.2
2.249	2.2
2.25	2.3
2.35	2.4
2.97	3.0

VI.4.2 Determination of BTU Quantity of LNG Delivered:

The BTU quantity of LNG delivered is computed by use of the formula:

$$Q = [(V \times D \times H_m / 1055.06) - Q_R - Q_F] \times (1 - FCI)$$

where:

Q is the BTU quantity delivered. The BTU quantity shall be rounded to the nearest ten (10) million BTU's;

V is the volume of the LNG unloaded, stated in Cubic Meters. The volume shall be rounded to the nearest Cubic Meter;

D is the density of the LNG, stated in kilograms per Cubic Meter at temperature T_L . The density shall be rounded to the nearest tenth (0.1) of a kg/m³;

T_L is the temperature of the LNG in the tanks of the LNG Tanker before unloading, stated in degrees Celsius to the nearest tenth (0.1) degree C;

H_m is the Gross Heating Value of the LNG, stated in MJ per kilogram. The Gross Heating Value shall be rounded to the nearest hundredth (0.01) of a MJ/kg;

$V \times D \times H_m / 1055.06$ " $V \times D \times H_m / 1055.06$ " shall be calculated and rounded to the nearest million BTU's; and

Q_R is the BTU quantity of the vapor which was displaced by the volume of the LNG

Courtesy translation, not binding.

unloaded (V), and shall be rounded to the nearest million BTU's;

Q_R is computed by use of the formula:

$$Q_R = V \times \left(\frac{288.15}{273.15 + T_V} \right) \times \left(\frac{P_a}{1013.25} \right) \times \left(\frac{35}{1055.06} \right)$$

where:

T_V is the temperature of the vapor in the tanks of the LNG Tanker after unloading, stated in degrees Celsius to the nearest tenth (0.1) degree C;

$\frac{288.15}{273.15 + T_V}$ " $\frac{288.15}{273.15 + T_V}$ corrects the vapor temperature T_V to (15°C) (-----) and shall be rounded to three decimal places;

P_a is the absolute pressure of the vapor in the tanks of the LNG Tanker after unloading, stated in millibars to the nearest mBar;

$\left(\frac{P_a}{1013.25} \right)$ " $\left(\frac{P_a}{1013.25} \right)$ corrects the vapor pressure P_a to 1013.25 mBar and shall be rounded to three decimal places;

$$V \times \left(\frac{288.15}{273.15 + T_V} \right) \times \left(\frac{P_a}{1013.25} \right) \times \left(\frac{35}{1055.06} \right) \text{ " } V \times \left(\frac{288.15}{273.15 + T_V} \right) \times \left(\frac{P_a}{1013.25} \right) \times \left(\frac{35}{1055.06} \right) \text{ "}$$

shall be calculated and rounded to the nearest million BTU's; and

$V \times D \times H_m / 1055.06 - Q_R$ " $V \times D \times H_m / 1055.06 - Q_R$ " shall be calculated and rounded to the nearest ten million BTU's

Q_F is the equivalent amount in BTU of Boil-off gas consumed by the LNG Tanker as fuel during the discharge. Q_F is computed by use of the formula:

$$Q_F = VF \times 288.15 \times \frac{35 \text{ (or 50)}}{1055.06}$$

where:

VF is the amount of Boil-off gas consumed by the LNG Tanker as fuel and if expressed in standard cubic meters it will be rounded to the nearest standard cubic meter.

FCI is the Correction Factor for the Uncertainty inventory's Loss and/or Gain and has the meaning given in clause 6.3 of Chapter III, expressed in percentage terms and rounded to the second decimal places.

VI.4.3 Determination of LNG Density -

The density of the LNG is calculated by use of the formula:

$$\Sigma (X_i \times M_i)$$

Courtesy translation, not binding.

$$D = \frac{\Sigma (X_i \times V_i) - (K1 + (K2 - K1) \times X_n) \times X_m}{\left\{ \frac{\quad}{0.0425} \right\}}$$

where:

D is the density of the LNG, stated in kilograms per Cubic Meter at temperature T_L. The density shall be rounded to the nearest tenth (0.1) of a kg/m³;

T_L is the temperature of the LNG in the tanks of the LNG Tanker before unloading, stated in degrees Celsius to the nearest tenth (0.1) degree C;

X_i is the mol fraction, to the nearest fourth (4th) decimal place, of component (i) from the composition obtained in accordance with Section V hereof. The mol fraction of methane shall be adjusted so as to make the total mol fraction equal to 1.0000;

M_i is the molecular weight of component (i) as set forth in Table 1 attached hereto;

Σ (X_i x M_i) The result of the calculation of "X_i x M_i" of component (i) shall be rounded to the nearest fourth (4th) decimal place, and then, "Σ(X_i x M_i)" shall be calculated to the nearest fourth (4th) decimal place;

V_i is the molar volume, to the nearest sixth (6th) decimal place, of component (i), stated in Cubic Meters per kilogram-mol at temperature T_L, and shall be obtained by linear interpolation of the data set forth in Table 2 attached hereto;

Σ (X_i x V_i) The result of the calculation of "X_i x V_i" of component (i) shall be rounded to the nearest sixth (6th) decimal place, and then "Σ(X_i x V_i)" shall be calculated to the nearest sixth (6th) decimal place;

X_m is the mol fraction, to the nearest fourth (4th) decimal place, of methane from the composition obtained in accordance with Section V hereof;

X_n is the mol fraction, to the nearest fourth (4th) decimal place, of nitrogen from the composition obtained in accordance with Section V hereof;

K1 is the volume correction, to the nearest sixth (6th) decimal place, stated in Cubic Meters per kilogram-mol at temperature T_L and obtained by linear interpolation of the data set forth in Table 3 attached hereto;

K2 is the volume correction, to the nearest sixth (6th) decimal place, stated in Cubic Meters per kilogram-mol at temperature T_L and obtained by linear interpolation of the data set forth in Table 4 attached hereto.

$\left\{ \frac{(K1 + (K2 - K1) \times X_n) \times X_m}{0.0425} \right\}$ “(K1 + (K2 - K1) x X_n) x X_m” shall be calculated to the nearest sixth (6th) decimal place; and

$$\Sigma (X_i \times V_i) - (K1 + (K2 - K1) \times X_n) \times X_m$$

$$\left\{ \frac{\quad}{0.0425} \right\}$$

“Σ (X_i x V_i) Σ (X_i x V_i) - (K1+ (K2 -K1) x X_n) x X_m “ shall be calculated to the nearest sixth (6th) decimal place.

VI.4.4 Determination of Gross Heating Value

VI.4.4.1 The Gross Heating Value (mass basis) of the LNG is calculated by use of the formula:

$$H_m(t_1) = \frac{\sum (X_i \times H_{vi}(t_1))}{\sum (X_i \times M_i)}$$

where:

- H_m is the Gross Heating Value of the LNG, stated in MJ/s per kilogram. The Gross Heating Value shall be rounded to the nearest hundredth (0.01) of a MJ / kg;
- H_{vi} is the Gross Heating Value of component (i), stated in KJ / mol, as set forth in Table 1 attached hereto;
- X_i is the mol fraction, to the nearest fourth (4th) decimal place, of component (i) from the composition obtained in accordance with Section V hereof. The mol fraction of methane shall be adjusted so as to make the total mol fraction equal to 1.0000;
- $X_i \times H_{vi}(t_1)$ "X_i x H_{vi} (t₁)" shall be calculated and rounded to the nearest fourth (4th) decimal place;
- $\sum X_i \times H_{vi}(t_1)$ "Σ X_i x H_{vi} (t₁)" shall be calculated and rounded to the nearest fourth (4th) decimal place;
- M_i is the molecular weight of component (i) as set forth in Table 1 attached hereto;
- $X_i \times M_i$ "X_i x M_i" of component (i) shall be calculated to the nearest fourth (4th) decimal place; and
- $\sum(X_i \times M_i)$ "Σ (X_i x M_i)" shall be calculated to the nearest fourth (4th) decimal place by summing all "X_ix M_i" obtained as above.

VI.4.4.2 The Gross Heating Value (volume basis) of the LNG shall be calculated by use of the formula:

$$H_v [t_1, V(t_2, p_2)] = \frac{101.325 \times (\sum (X_i \times H_{vi} [t_1, V(t_2, p_2)])}{R \times 288.15 \times z_{mix} (t_2, p_2)}$$

where:

- H_v is the Gross Heating Value of LNG, stated in MJ/s per SCM. The Gross Heating Value shall be rounded to the nearest hundredth (0.01) of a MJ / SCM;
- X_i is the mol fraction, to the nearest fourth (4th) decimal place, of component (i) from the composition obtained pursuant to Section V hereof. The mol fraction of methane shall be adjusted so as to make the total mol fraction equal to 1.0000;
- H_{vi} is the Gross Heating Value of component (i), stated in KJ / mol, as set forth in Table 1 attached hereto;
- $X_i \times H_{vi} [t_1, V(t_2, p_2)]$ "X_i x H_{vi} (t₁)" shall be calculated and rounded to the nearest fourth (4th) decimal place;

$\sum X_i \times H_{vi} [t_1, V(t_2, p_2)]$ “ $\sum X_i \times H_{vi} (t_1)$ ” shall be calculated and rounded to the nearest fourth (4th) decimal place; and

R is the molar gas constant = 8.314510 J per mol per K

$z_{mix} (t_2, p_2)$ is the compression factor, rounded to the nearest fifth (5th) decimal place, under standard conditions calculated in accordance with:

$$z_{mix} (t_2, p_2) = 1 - (\sum X_i \times \sqrt{b_i})^2$$

where:

$\sqrt{b_i}$ is the summation factor of component (i) as set forth in Table 1 attached hereto;

$X_i \times \sqrt{b_i}$ “ $X_i \times \sqrt{b_i}$ ” shall be calculated for component (i) to the nearest fifth (5th) decimal place;

$(\sum X_i \times \sqrt{b_i})^2$ shall be calculated to the nearest fifth (5th) decimal place.

VI.4.4.3 The determination of the Wobbe Index for the purposes of Annex (i) of the Regasification Code shall be calculated by use of the formula:

$$\text{Wobbe Index} = \frac{H_v [t_1, V(t_2, p_2)]}{\text{square root } \{[(\sum (X_i \times M_i)) / 28.9626] \times [0.99958 / z_{mix} (t_2, p_2)]\}}$$

where:

Wobbe Index is the Gross Heating Value of LNG, stated in MJ per Standard Cubic Meter divided by the square root of the Specific Density. The Wobbe Index shall be rounded to the nearest hundredth (0.01) of a MJ/SCM;

H_v is the Gross Heating Value of LNG, calculated and obtained in accordance with Section VI.2.2 hereof shall be rounded to the nearest hundredth (0.01) of a MJ/SCM;

X_i is the mol fraction, to the nearest fourth (4th) decimal place, of component (i) from the composition obtained pursuant to Section V hereof. The mol fraction of methane shall be adjusted so as to make the total mol fraction equal to 1.0000;

M_i is the molecular weight of component (i) as set forth in Table 1 attached hereto; and

$z_{mix} (t_2, p_2)$ is the compression factor, rounded to the nearest fifth (5th) decimal place, under standard conditions calculated in accordance with:

$$z_{mix} (t_2, p_2) = 1 - (\sum X_i \times \sqrt{b_i})^2$$

where:

$\sqrt{b_i}$ is the summation factor of component (i) as set forth in Table 1 attached hereto;

$X_i \times \sqrt{b_i}$ “ $X_i \times \sqrt{b_i}$ ” shall be calculated for component (i) to the nearest fifth (5th) decimal place; and

Courtesy translation, not binding.

$(\sum X_i \times \sqrt{b_i})^2$ shall be calculated to the nearest fifth (5th) decimal place.

PART B - GAS TESTING AND MEASURING METHOD

SECTION VII - GAS MEASUREMENT

VII.1 Gas Measurement - General

The Gas from the Terminal is transmitted to the Cavarzere Entry Point through a 30" inside diameter pipeline that is comprised of an underwater section and a subsequent onshore section that connects to the metering station immediately upstream of the Cavarzere Entry Point.

The Gas measurement system at Cavarzere has a guaranteed error factor of less than one percent (1%). There are three (3) measurement lines (two (2) in operation and one (1) on stand-by), each equipped with its own flow computer for calculating the flow rates. The gas chromatographs and flow computers are installed in a dedicated building.

The values measured by the instruments (temperature, pressure, composition, flow rate) are sent to the DCS (Distributed Control System) of the Terminal by RTU card.

The instruments installed allow the following values to be calculated, in compliance with the ISO 6976 standards:

- (a) GHV in MJ/Sm³;
- (b) Density in kg/Sm³;
- (c) Specific Density;
- (d) Compression factor; and
- (e) Wobbe Index.

Detailed measurement procedures for Gas are as specified in the network code for the Grid.

TABLE I
PHYSICAL CONSTANTS

Component	Molecular Weight M_i (kg/kmol)	Gross Heating Value (KJ/mol) H_{vi}	Summation Factor $\sum b$
Methane (CH ₄)	16.043	891.56	0.0447
Ethane (C ₂ H ₆)	30.070	1562.14	0.0922
Propane (C ₃ H ₈)	44.097	2221.10	0.1338
Iso-butane (i-C ₄ H ₁₀)	58.123	2870.58	0.1789
Normal Butane (n-C ₄ H ₁₀)	58.123	2879.76	0.1871
Iso-pentane (i-C ₅ H ₁₂)	72.150	3531.68	0.2280
Normal Pentane (n-C ₅ H ₁₂)	72.150	3538.60	0.2510
Hexane Plus (C ₆ H ₁₄ +)	86.177	4198.24	0.2950
Nitrogen (N ₂)	28.0135	n/a	0.0173
Oxygen (O ₂)	31.9988	n/a	0.0283
Carbon Dioxide (CO ₂)	44.010	n/a	0.0748

The above table of Physical Constants, developed from ISO 6976:1995, shall be used for all density and heating value calculations associated with the Capacity Agreements. This table of Physical Constants shall be revised to conform to any subsequent officially published revision of ISO 6976. The values for the Gross Heating Value in KJ/mol and Summation Factor as shown above are based on references of 15°C and 1.01325 bar

TABLE 2 - MOLAR VOLUMES OF INDIVIDUAL COMPONENTS

Molar Volumes (m³/kg-mol) at Various Temperatures x 10³

	<u>-165°C</u>	<u>-160°C</u>	<u>-155°C</u>	<u>-150°C</u>
CH ₄	37.500	38.149	38.839	39.580
C ₂ H ₆	47.524	47.942	48.369	48.806
C ₃ H ₈	62.046	62.497	62.953	63.417
i-C ₄ H ₁₀	77.851	78.352	78.859	79.374
n-C ₄ H ₁₀	76.398	76.875	77.359	77.847
i-C ₅ H ₁₂	91.179	91.721	92.267	92.817
n-C ₅ H ₁₂	91.058	91.583	92.111	92.642
C ₆ H ₁₄₊	104.34	104.89	105.45	106.02
N ₂	44.043	47.019	51.022	55.897

Reference: The above table of Molar Volumes, as referenced in ISO 6578 – 91, shall be used for all density and heating value calculations associated with the Regasification Code. This table of Molar Volumes shall be revised to conform to any subsequent officially published revision of ISO 6578 - 91.

- Note:**
1. For intermediate temperatures a linear interpolation shall be applied.
 2. The above values are expressed as the values derived after multiplying by 10³ to avoid an excessive number of decimal places in the table. When applying the values, a compensating multiplier of 10⁻³ should be entered to reduce the above values to the correct magnitude.

TABLE 3 - CORRECTION K1 FOR VOLUME REDUCTION OF MIXTURE

Molecular Weight of Mixture	K1(m ³ /kg-mol) at Various Temperatures x 10 ³			
	-165°C	-160°C	-155°C	-150°C
Σ(Xi x Mi)				
17.00	0.18	0.21	0.24	0.28
18.00	0.370.41	0.47	0.56	
19.00	0.510.58	0.67	0.76	
20.00	0.670.76	0.86	0.98	

Reference: The above table of Correction K1 for Volume Reduction, as referenced in ISO 6578 - 91, shall be used for all density and heating value calculations associated with the Regasification Code. This table of Correction K1 for Volume Reduction shall be revised to conform to any subsequent officially published revision of ISO 6578 - 91.

- Note:**
1. Molecular mass of mixture equals $\Sigma(X_i \times M_i)$.
 2. For intermediate values of temperature and molecular mass a linear interpolation shall be applied.
 3. The above values are expressed as the values derived after multiplying by 10³ to avoid an excessive number of decimal places in the table. When applying the values, a compensating multiplier of 10⁻³ should be entered to reduce the above values to the correct magnitude.

TABLE 4 - CORRECTION K2 FOR VOLUME REDUCTION OF MIXTURE

Molecular Weight of Mixture	K2(m ³ /kg-mol) at Various Temperatures x 10 ³			
	-165°C	-160°C	-155°C	-150°C
Σ(Xi x Mi)				
17.00	0.29	0.46	0.68	0.91
18.00	0.530.67	0.84	1.05	
19.00	0.710.88	1.13	1.39	
20.00	0.861.06	1.33	1.62	

Reference: The above table of Correction K2 for Volume Reduction, as referenced in ISO 6578 - 91, shall be used for all density and heating value calculations associated with the Regasification Code. This table of Correction K2 for Volume Reduction shall be revised to conform to any subsequent officially published revision of ISO 6578 - 91.

- Note:**
1. Molecular mass of mixture equals Σ(Xi x Mi).
 2. For intermediate values of temperature and molecular mass a linear interpolation shall be applied.
 3. The above values are expressed as the values derived after multiplying by 10³ to avoid an excessive number of decimal places in the table. When applying the values, a compensating multiplier of 10⁻³ should be entered to reduce the above values to the correct magnitude.

Annex (k) Gas Redelivery Procedure

Introduction

The Redelivery Service provided by the Operating Company is governed by the main body of the Regasification Code, and by this Gas Redelivery Procedure, which has been drafted in order to comply with the provisions of (i) AEEG Resolution no. 167 of 1 August 2005 and with the indications of the related Technical Report (“*Relazione Tecnica*”), which provides that “*the modalities for apportioning the gas redelivered among the various users shall also allow the redelivery to each user with a continuous profile during the course of the month, in order to guarantee the continuity of supplies to the users of the continuous regasification service, which have the availability of regasification capacity allowing a single unloading per month*” and (ii) the Transportation Contract. The Redelivery Service is composed of two main activities: the making available of Gas to the User at the Redelivery Point on a provisional basis; and the determination of the final actual quantities of Gas to which such User is entitled during the relevant period.

In order to allow a continuous redelivery profile for each Continuous User, the running of the algorithm described in Part 1 below implies the redelivery of LNG quantities, during the course of the Month, which could be in excess of such Users’ respective daily inventories. The Continuous Users authorise the Operating Company to communicate the information relating to their daily inventories to the respective counterparties.

Part 1: Continuous Users and Transportation System Users

The provisional and final actual quantities of Gas redelivered to Continuous Users or to Transportation System Users indicated by the User according to the article 10bis6 of AEEG Resolution n.167/05 (as modified by AEEG Resolution n. 297/2012/R/Gas) as the case may be, shall be determined as follows:

Monthly Redelivery Programme

By the 21^o (twenty-first) day, or the following Business Day if the 21 (twenty-one) is not a Business Day, of the Month before the beginning of the Month M, the Operating Company will prepare and publish the two Monthly Redelivery Programme proposals as of comma a) of article 6.1.4 of Chapter III for each Continuous User. The Monthly Redelivery Programme proposals as of comma a) of article 6.1.4 of Chapter III, based upon the applicable Three Month Schedule, will show the total quantity of Gas (expressed in energy (GJ)) the Operating Company plans to make available at the Redelivery Point on a provisional basis to such User or to the Transportation System Users indicated by the User according to article 10bis6 of AEEG Resolution n.167/05 (as modified AEEG n. 297/2012/R/Gas each Day of Month M. By the first Business Day following the publication of the two proposals each User will express his preference between the proposals made by the Operating Company. It remains the right for the User to ask for some modifications to the above mentioned proposals within the deadlines foresee at article 6.1.4 of Chapter III. By the third Business Day prior to the start of the Month M, the Operating Company shall notify each User the respective Monthly Redelivery Programme.

The Monthly Redelivery Programme will be determined through the following two-step process:

Courtesy translation, not binding.

Step 1: for each Day d of Month M , the Operating Company will initially estimate the quantity of LNG that will be available in the Terminal tanks (using Formulas (1), (2) and (3)) for each User and, subsequently, estimate the quantities of Gas that will be available for redelivery (using Formula (3)) for each User; and

Step 2: the Operating Company will determine the redelivery profiles (i.e., the quantities of Gas that will be redelivered to each User k on each Day d of Month M) by applying the monthly average shares of the results from Steps 1 and 2 to the total Gas redelivery volumes for the Month M (Formulas (4) and (5)).

Step - 1: Estimation of LNG available in the Terminal's tanks and Gas available for redelivery per User per Day

The estimated quantity of LNG available for a User k on day d (ED_d^k) is calculated on the basis of the following formula such estimate takes into account the estimated quantities of Losses and Consumption

:

Formula (1)

$$ED_d^k = ES_d^k + ECN_d^k$$

Where:

ES_d^k = estimated quantity of LNG (expressed in GJ) available in the Terminal's tanks for User k at 06:00 hours on day d , that will remain after having deducted the quantity of Gas that is estimated has been redelivered to User k (or to the Transportation System Users indicated by the User, who will receive their Gas quantities according to article 10bis6 of AEEG Resolution n. 167/05 as modified by AEEG Resolution n. 297/2012/R/Gas) on day $d-1$ (calculated using Formula (3) for $d-1$).

ECN_d^k = net estimated quantity of LNG (expressed in GJ) Unloaded by User k on day d , expressed in GJ, according to the following formula:

$$ECN_d^k = (1 - c) * EC_d^k$$

c = percentage value defined by the Regulatory Authority for Electricity and Gas to cover the Losses and Consumption

EC_d^k = Estimated quantity of LNG delivered by the User k on day d . If the unloading operations are referred to a period impacting two consecutive months, the quantity will correspond to the unloading quantities of each month

d = 1 to M , with M being the natural number identifying the last calendar day of the Month

Courtesy translation, not binding.

M. Day d is the period of twenty four (24) consecutive hours starting at 06:00 hours (Italian time) of such calendar day and ending at the same hour on the following calendar day

k = the particular Continuous User during the relevant period.

Consequently, the total quantity of LNG that is estimated will be available in the Terminal's tanks for all Continuous Users on Day d is determined pursuant to the following formula:

Formula (2)

$$ED_d^T = \sum_{k=1}^j ED_d^k$$

Where:

j = the number of Continuous Users.

The quantity of Gas that is estimated will be available for redelivery to each User k on Day d (EP_d^k) is determined as a share of the total quantity of Gas that is estimated will be redelivered on Day d (EP_d^T), proportional to the quantity of LNG in the Terminal's tanks available for User k on Day d (ED_d^k), compared to the total quantity of LNG that is estimated will be in the Terminal's tanks available for all Continuous Users on day d (ED_d^T).

More specifically:

Formula (3)

$$EP_d^k = EP_d^T * \frac{ED_d^k}{ED_d^T}, \quad \text{with} \quad EP_d^T = \sum_{k=1}^j EP_d^k$$

Where:

EP_d^T = the estimated total quantity of Gas (expressed in GJ) available for redelivery on Day d , after deduction of (i) the quantity of Gas redelivered to Spot Users (or to the Transportation System Users indicated by the Spot User, who will receive their Gas quantities according to article 10bis6 of AEEG Resolution n. 167/05 as modified by AEEG Resolution n. 297/2012/R/Gas) and (ii) the increasing or decreasing Gas quantity as a result of the Flexibility Service and/or Temporary Storage Services, as the case may be, to User k on Day d .

Note: The methodology described above may lead to reduced values for term EP_d^k that are operationally insignificant when the term ED_d^k becomes close to zero. Consequently, when ED_d^k reaches a minimum value of 1,000 GJ, the quantity of Gas that is estimated will be

Courtesy translation, not binding.

redelivered for User k , EP_d^k , will be deemed to be equal to ED_d^k .

Step – 2: Determination of redelivery profiles

Using the data generated applying Formulas (1), (2), (3) for User k for all Days d of Month M , the Operating Company shall calculate the overall monthly quantity of Gas to be redelivered to each User (or to the Transportation System Users indicated by the User who will receive their Gas quantities according to article 10bis6 of AEEG Resolution n. 167/05 as modified by AEEG Resolution n. 297/2012/R/Gas) k ($\sum_{d=1}^M EP_d^k$), and the overall monthly quantity to be redelivered to

all Users ($\sum_{d=1}^M EP_d^T$).

The resulting ratio, ($Ratio(EP)_M^K$), is User k 's percentage of the total quantity of Gas to be redelivered to all Continuous Users (or to the Transportation System Users indicated by the Spot User who will receive their Gas quantities according to article 10bis6 of AEEG Resolution n. 167/05 as modified by AEEG Resolution n. 297/2012/R/Gas) during the Month M . This percentage is then applied to the total quantity of Gas (expressed in GJ) that is estimated will be redelivered on day (d) (EP_d^T), in order to define the quantity of Gas estimated will be redelivered to each User (k) each day (d) of the Month M (EP_d^k).

Formula (4)

$$Ratio(EP)_M^K = \frac{\sum_{d=1}^M EP_d^k}{\sum_{d=1}^M EP_d^T}$$

The redelivery profile that provides rateable deliveries of Gas for each User (k) (or for Transportation System Users indicated by Spot User, who will receive their Gas quantities according to article 10bis6 of AEEG Resolution n. 167/05 as modified by AEEG Resolution n. 297/2012/R/Gas) on Day d is then determined pursuant to the following formula:

Formula (5)

Initial Gas (expressed in GJ) redelivery profile for each User (k) (or for the Transportation System User indicated by the Spot User who will receive the Gas quantities according to article 10bis6 of AEEG Resolution n. 167/05 as modified by AEEG Resolution n. 297/2012/R/Gas) and Day (d):

$$PEP_d^k = \frac{\sum_{d=1}^M EP_d^k}{\sum_{d=1}^M EP_d^T} * (EP_d^T)$$

Courtesy translation, not binding.

with M = last calendar day of the Month M

Where:

PEP_d^k is equal to the estimated quantity of Gas that will be redelivered to User (k) (or to the Transportation System Users indicated by the Spot User who will receive their Gas quantity according to article 10bis6 of AEEG Resolution n.167/05 as modified by AEEG Resolution n. 297/2012/R/Gas) in day (d)

EP_d^K is the estimated quantity of Gas that will be redelivered to User (k) in day (d) according to Formula (3) above

EP_d^T is the estimated total quantity of Gas that will be redelivered to all Continuous Users in day d .

Adjusted Monthly Redelivery Programme

The Monthly Redelivery Programme will be adjusted daily (such adjusted Monthly Redelivery Programme is referred to as the "**Adjusted Monthly Redelivery Programme**") and, as adjusted, will serve as the basis for the nominations to the Transportation Company. Such adjustments shall be based on the results from running the above algorithms each day, using the latest known actual data and the latest estimated data.

The Operating Company shall endeavour to communicate the Adjusted Monthly Redelivery Programme:

- following changes related to the exercise of the right stated in article 6.1.4 letter (d) in Chapter III, by or before 5 pm every Day $d-2$ for Day d ; and
- following changes related to the exercise of the right stated in article 6.1.4 letter (d) in Chapter III in the event of Spot capacity allocation, by or before the fourth day prior to the start of the relevant Slot Scheduled Arrival Range.

Each Adjusted Monthly Redelivery Programme shall take into account all circumstances contemplated under the main body of the Regasification Code, including:

- Early or late arrivals of LNG Tankers;
- Rescheduling of planned Unloadings;
- Differences between the quantities of LNG expected to be Unloaded during the Month and actual quantities Unloaded;
- Scheduling of Spot cargoes during the Month;
- Reductions in Terminal and/or Grid capacity;
- The need for sufficient ullage in the Terminal's tanks to accommodate the next Unloading.
- Changes in the expected Terminal's Losses and Consumption

Adjusted Monthly Redelivery Programme following requests for additional services.

The Monthly Redelivery Programme/Adjusted Monthly Redelivery Programme shall be modified following requests for additional services from the User and relevant confirmation by the Operating Company according to article 3.8 of Chapter II and of Annex (o). If additional services are requested by a User k , the User k redelivery profile will be increased or decreased on Day d following the supply of Flexibility Service and/or Temporary Storage Service and this change will be included in the "Adjusted Monthly Redelivery Program following requests for additional

Courtesy translation, not binding.

services".

Determination of the actual quantities of Gas to which Continuous Users are entitled

Subject to the provisions of the codes of the Transportation Company by the 2nd (second) Business Day of each Month, the Operating Company shall provide each User with a gas quantity entitlement report that shows the actual quantities of Gas which the User was entitled to receive each Day during the previous Month. The quantities of Gas actually redelivered to each Continuous User (or to the Transportation System Users, indicated by the User, who will receive their Gas quantities according to article 10bis6 of AEEG Resolution n. 167/05 as modified by AEEG Resolution n. 297/2012/R/Gas) on each Day d will be calculated by applying the algorithms described below, utilizing actual data.

Should the quantities of Gas actually redelivered to each Continuous User on each Day d of the previous Month, as shown on the gas quantity entitlement report, differ from the quantities nominated at the System by the Operating Company during the course of that Month on the basis of the Monthly Redelivery Programme and the Adjusted Monthly Redelivery Programme following requests for additional services, the Operating Company shall carry out the transactions at the System in order to match the Final Redelivery Profiles of all the Users involved, but will not be obliged to make any transactions, in the relevant session, in order to amend daily or infra-daily redelivery profile to each affected User.

Step - 1: Determination of LNG available in the Terminal's tanks and Gas available for redelivery per User per Day

The quantity of LNG available for a User k on Day d (ED_d^k) is calculated on the basis of the following formula, using actual data:

Formula (1')

$$ED_d^k = ES_d^k + ECN_d^k$$

Where:

ES_d^k = available LNG for User k at 06:00 hours on day d , calculated subtracting from ED_{d-1}^k quantities of Gas redelivered to User k on day $d-1$ (calculated using Formula (3') for $d-1$), expressed in GJ

ECN_d^k = net actual quantity of LNG (expressed in GJ) Unloaded by User k on day d , expressed in GJ, according to the formula:

$$ECN_d^k = (1 - c) * EC_d^k$$

c = percentage value defined by the Regulatory Authority for Electricity and Gas to cover the Losses and Consumption

Courtesy translation, not binding.

EC_d^k = quantity of LNG Unloaded by the User k on day d . If the unloading operations are referred to a period having effect on two consecutive months, the quantity will correspond to the unloading quantities of such particular month

d = 1 to M , with M being the natural number identifying the last calendar day of the Month M . Day d is the period of twenty four (24) consecutive hours starting at 06:00 hours (Italian time) of such calendar day and ending at the same hour on the following calendar day

k = the particular Continuous User during the relevant period.

Consequently, the overall final availability of LNG in the Terminal tanks on day d is obtained applying the following formula:

Formula (2')

$$ED_d^T = \sum_{k=1}^j ED_d^k$$

Where:

j = the number of Continuous Users

The quantity of Gas available for redelivery on day d to each User k is determined as a quota of the total quantity of Gas actually redelivered on day d , proportional to the quantity of LNG in the Terminal tanks available for User k on day d (as determined under Formula (1')) compared to the total actual quantity of LNG in the Terminal tanks available for all Users on day d (as determined under Formula (2')).

More specifically:

Formula (3')

$$ER_d^k = ER_d^T * \frac{ED_d^k}{ED_d^T}$$

Where:

ER_d^T = the quantity of Gas available for redelivery on day d , expressed in GJ, after deduction of (i) the quantity of Gas redelivered to the Spot Capacity Users (or to the Transportation System Users indicated by the Spot User, who will receive their Gas quantity according to article 10bis6 of AEEG Resolution n. 167/05 as modified by AEEG Resolution n. 297/2012/R/Gas) and (ii) the increasing or decreasing Gas quantity following the supply of the Flexibility Service and/or the Temporary Storage Service, as the case may be, to User k , on Day d .

Courtesy translation, not binding.

Note: The methodology described above may lead to reduced values for term ER_d^k that are operationally insignificant when the term ED_d^k becomes close to zero. Consequently, when ED_d^k reaches a minimum value of 1,000 GJ, the quantity of Gas redelivered for User k , ER_d^k , will be deemed to be equal to ED_d^k .

Step – 2: Determination of Final Redelivery Profiles

Using the data generated by the *Formulas* (1'), (2') and (3'), the Operating Company shall calculate the total monthly quantity of Gas actually redelivered to each User ($\sum_{d=1}^M ER_d^k$) compared to the total monthly quantity of Gas actually redelivered to all Users ($\sum_{d=1}^M ER_d^T$).

The resulting ratio ($Ratio(ER)_M^K$) is the monthly percentage of Gas associated with each User (k).

Formula (4')

$$Ratio(ER)_M^K = \frac{\sum_{d=1}^M ER_d^k}{\sum_{d=1}^M ER_d^T}$$

This ratio is then applied to the total quantity of Gas actually redelivered on day (d) (ER_d^T), expressed in GJ, in order to define the quantity of Gas actually redelivered to each User (k) each day (d) of the Month (ER_d^k) (the “**Final Redelivery Profile**”).

Formula (5')

Actual Gas (expressed in GJ) redelivery profile for each User (k) and Day (d):

$$PER_d^k = \frac{\sum_{d=1}^M ER_d^k}{\sum_{d=1}^M ER_d^T} * (ER_d^T)$$

with M = last calendar day of the Month M

Where:

PER_d^K equal to the quantity of Gas redelivered to User (k) in day (d)

ER_d^T equal to the total quantity of Gas redelivered to all Continuous Users in day (d).

Courtesy translation, not binding.

The volumes related to the Gas quantities' increase or decrease following the supply of the Flexibility Service and/or the Temporary Storage Service, according to article 3.8 of Chapter II and of Annex (o), to the User k on Day d , will be allocated on the base of the actual volume made available to User k on Day d .

Part 2: Spot Users

The Operating Company will develop a Spot Redelivery Programme setting out the quantity of Gas that will be redelivered each Day d of the relevant Spot Redelivery Period for each Spot User (or to the Transportation System Users, indicated by the Spot Capacity User, who will receive their Gas quantity according to article 10bis6 of AEEG resolution n. 167/05 as modified by AEEG Resolution n. 297/2012/R/Gas), taking into account all relevant factors (including those set forth in the User's Spot Capacity Agreement).

The Spot Redelivery Programme will be adjusted as appropriate (such adjusted Spot Redelivery Programme is hereinafter referred to as the "**Adjusted Spot Redelivery Programme**") and, as adjusted, will serve as the basis for the nominations to the Transportation Company.

The Adjusted Spot Redelivery Programme shall take into account all circumstances contemplated under the main body of the Regasification Code, including:

- Early or late arrivals of LNG Tankers;
- Rescheduling of planned Unloadings;
- Differences between the quantities of LNG expected to be Unloaded during the Month and actual quantities Unloaded;
- Scheduling of Spot cargoes during the Month;
- Reductions in Terminal and/or Grid capacity;
- The need for sufficient ullage in the Terminal's tanks to accommodate the next Unloading.

The Spot Redelivery Programme/Adjusted Spot Redelivery Programme shall be modified following the request for additional services from Spot Capacity User and the relevant confirmation from the Operating Company according to article 3.8 of Chapter II and of Annex (o). In case of request of additional services from a Spot Capacity User, the Redelivery profile of the same User will be increased or decreased on day d following the supply of the Flexibility Service and/or the Temporary Storage Service, and this change will be reported in the "**Adjusted Spot Redelivery Programme following the requests for additional services**".

Annex (I)

Location of the Terminal

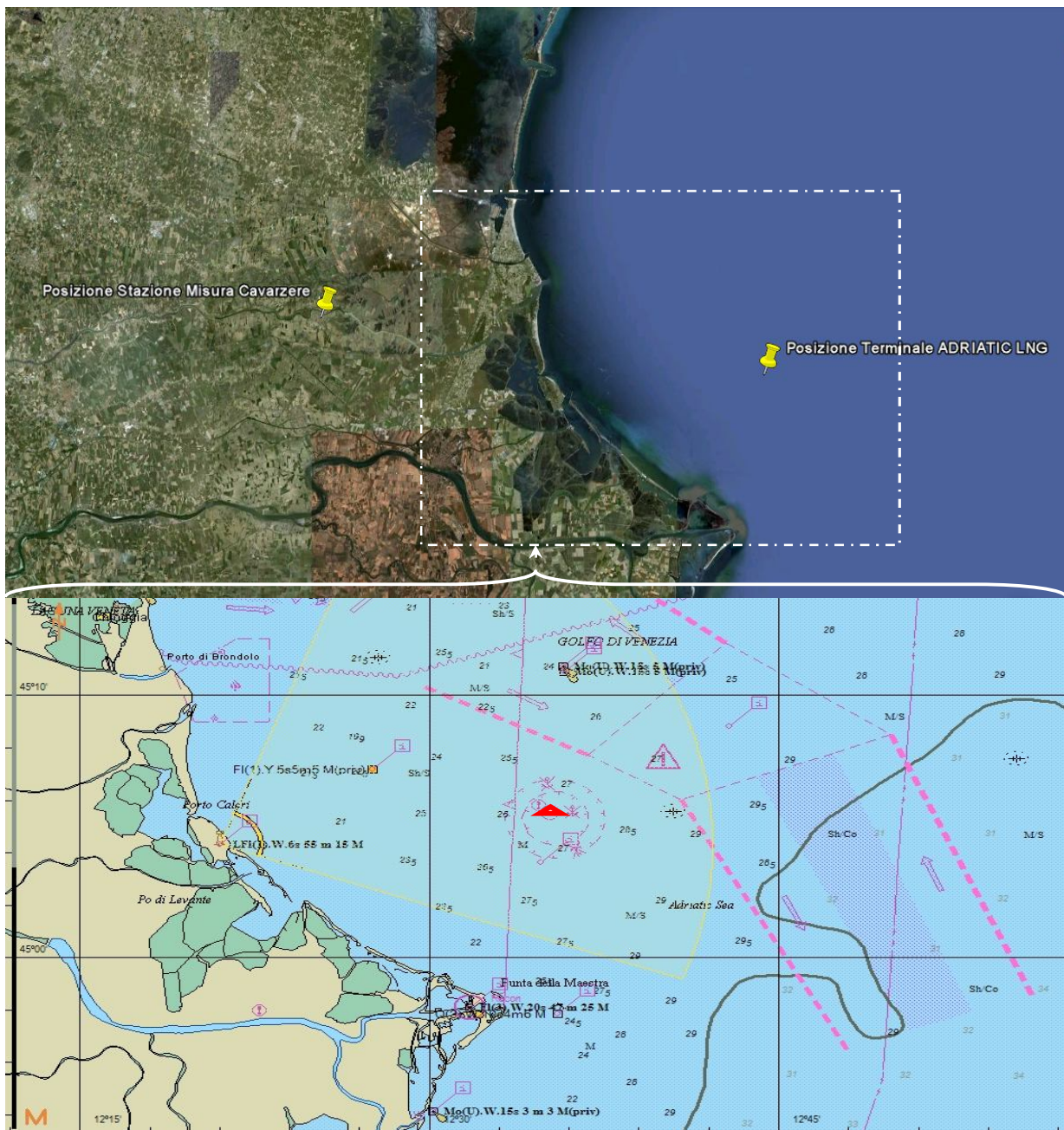

▲ ADRIATIC LNG Terminal - Coordinates:

45° 05' 26.30" N

12° 35' 04.99" E

Annex (m)

Plan

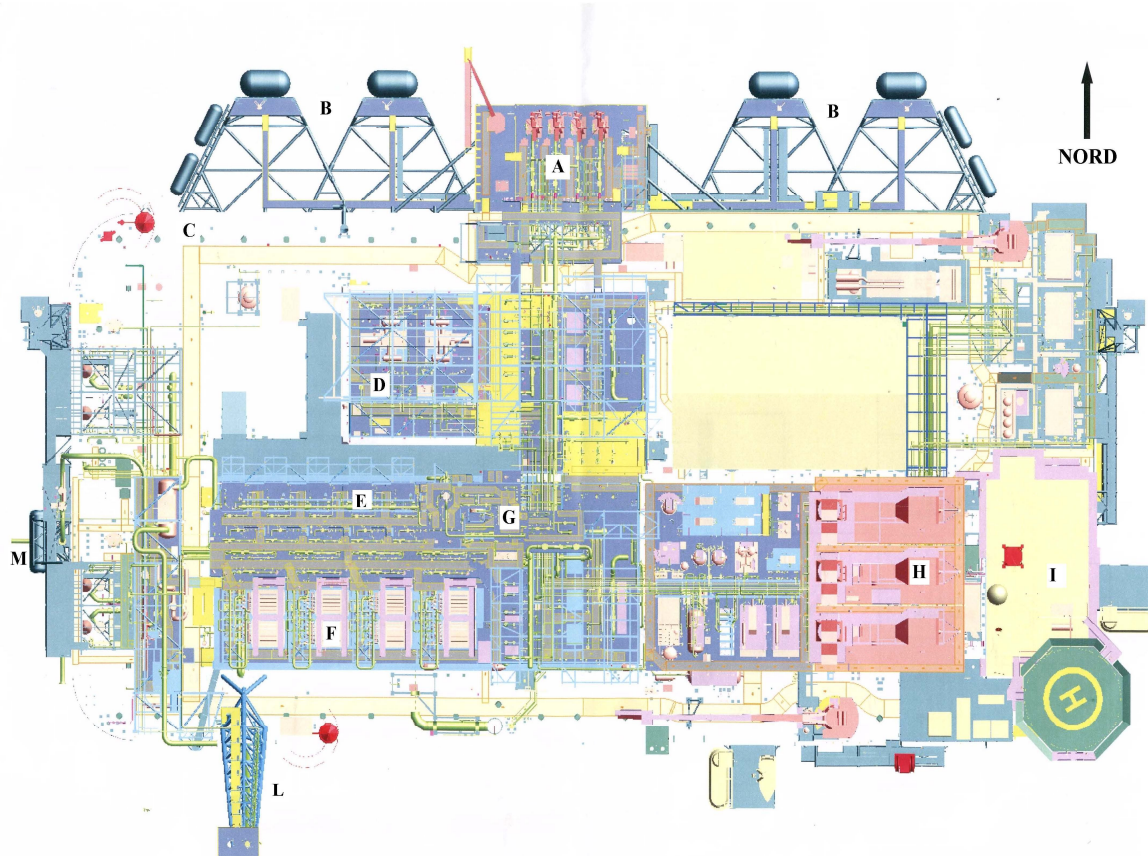

LEGENDA

- A= Loading Arms
- B= Fenders
- C= Tanks
- D= Boil-off gas recover
- E= High pressure booster pumps
- F= Vaporizers
- G= Waste Heat Recovery
- H= GTGs
- I = Living quarters
- L= Flare
- M= Gas pipeline

Annex (n)

Description of berthing facilities

Adriatic LNG Terminal – Berthing structures

- 138.000-152.000 cubic meter LNG Tanker (*Membranes*)

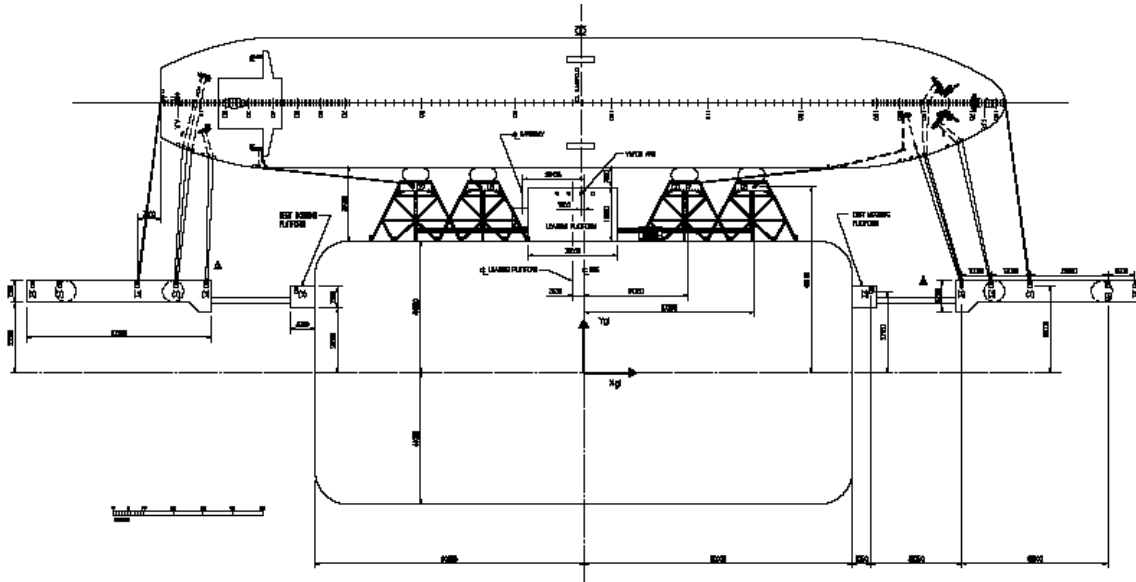

Mooring Lines	HS1	HS2	HS3	HS4	HS5	HS6	HS7	HS8
Hook	1 2	1 2 3	1 2 3	1 2 3	1 2 3	1 2 3	1 2	1 2
Head/Stern			18 17					
Breast				16 15 14	13 12			
Spring							11 10	

Mooring Lines	HS9	HS10	HS11	HS12	HS13	HS14	HS15	HS16
Hook	1 2	1 2	1 2 3	1 2 3	1 2 3	1 2 3	1 2 3	1 2
Head/Stern								
Breast				7 6 5 4 3				
Spring	9 8					2 1		

Lines	Forward	Aft
Head/Stern	2	2
Breast	5	5
Spring	2	2
Total Lines:	18	

Courtesy translation, not binding.

- 145.000 cubic meter LNG Tanker (Spherical)

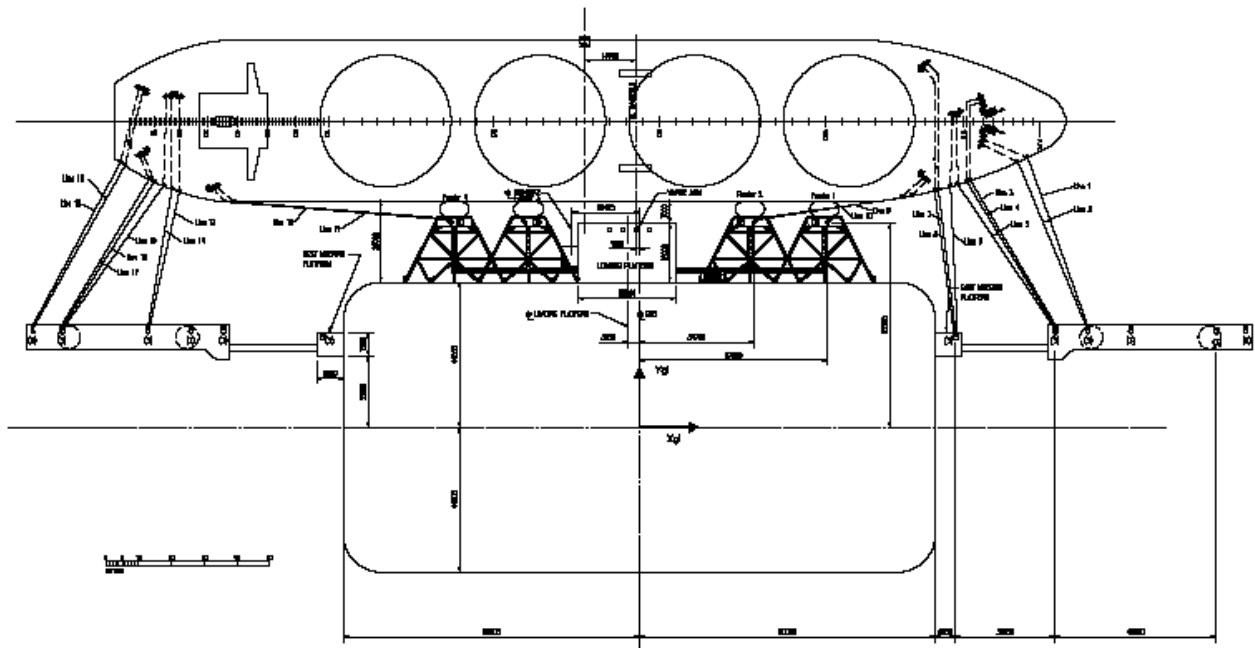

Mooring Lines	HS1		HS2			HS3			HS4			HS5			HS6			HS7		HS8	
Hook	1	2	1	2	3	1	2	3	1	2	3	1	2	3	1	2	3	1	2	1	2
Head/Stern	19	18																			
Breast			17	16	15	14	13														
Spring																		12	11		

Mooring Lines	HS9		HS10			HS11			HS12			HS13			HS14			HS15			HS16	
Hook	1	2	1	2	3	1	2	3	1	2	3	1	2	3	1	2	3	1	2	3	1	2
Head/Stern									2	1												
Breast						8	7	6	5	4	3											
Spring	10	9																				

Lines	Forward	Aft
Head/Stern	2	2
Breast	6	5
Spring	2	2
Total Lines:	19	

Courtesy translation, not binding.

- 138.000-152.000 cubic meter LNG Tanker with one loading arm (15metri offset).

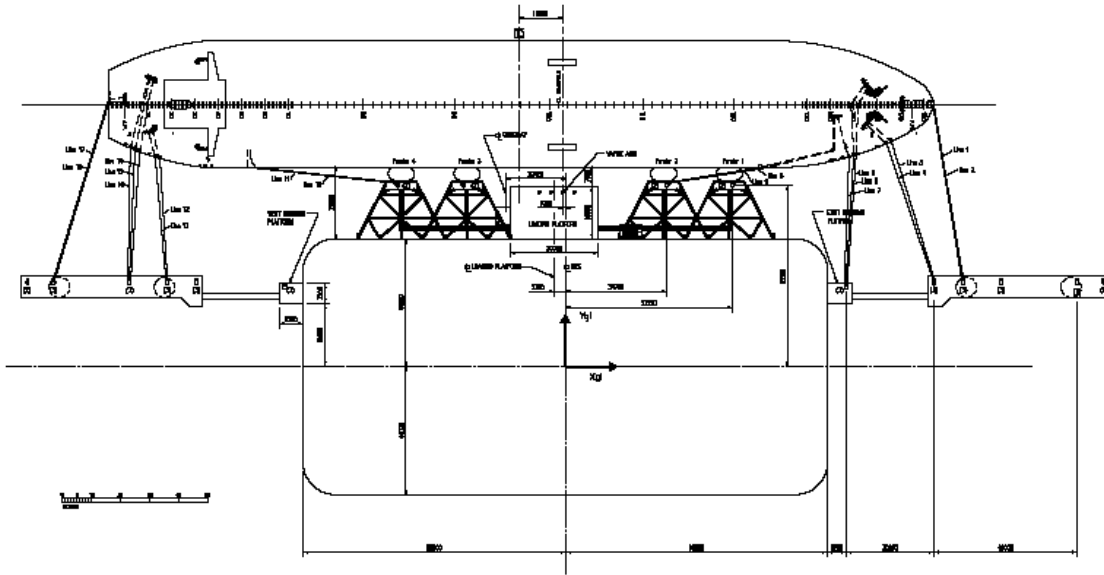

Mooring Lines	HS1		HS2		HS3			HS4			HS5			HS6			HS7		HS8		
Hook	1	2	1	2	3	1	2	3	1	2	3	1	2	3	1	2	3	1	2	1	2
Head/Stern					18	17															
Breast							16	15	14			13	12								
Spring																			11	10	

Mooring Lines	HS9		HS10		HS11			HS12			HS13			HS14			HS15			HS16	
Hook	1	2	1	2	1	2	3	1	2	3	1	2	3	1	2	3	1	2	3	1	2
Head/Stern											2	1									
Breast							7	6	5			4	3								
Spring	9	8																			

Lines	Forward	Aft
Head/Stern	2	2
Breast	5	5
Spring	2	2
Total Lines:	18	

Annex (o)

Additional Services: Flexibility Service and Temporary Storage Service

The Operating Company has the right to offer its Users, indiscriminately, additional services in addition to the Regasification Service as of article 3.8 of Chapter II.

The Flexibility Service and Temporary Storage Service that the Operating Company can offer are regulated by the provisions of the Regasification Code and this Annex (o), which has been drafted to align with the standards included in the AEEG Resolution 502/2013/R/Gas dated November 7, 2013 that requires, subject to Terminal technical configuration and the rate of use of Final Terminal Capacity, the Operating Company offers to its Users additional services that allow "a. to modify the Regasification program upon Users' request with timelines that are also compatible with the negotiation in the locational market session; b. to maintain the previously delivered LNG in terminal's storages".

Following are the provision, request, allocation, confirmation and distribution methods for Flexibility Service and Temporary Storage Service.

a) Flexibility Service

Except for the Redelivery operating flexibility stated in article 6.1.4 letter (a) in chapter III and Annex (k), Flexibility Service requires the Operating Company to make a service available to its Users that allows Users to request a change in the Monthly Redelivery Program, Spot Redelivery Program and/or Adjusted Monthly Redelivery Program, Adjusted Spot Redelivery Program accordingly, on Day D for Day D+1.

a.1) Subscription:

The User can request access to annual and/or semi-annual and/or monthly products by filling out the form available on the Electronic Communication System and sending it to the Operating Company.

The access request to annual and monthly products can be sent to the Operating Company within 5 pm of each Day while the subscription request to semi-annual products can be sent to the Operating Company according to the schedules indicated below:

- for the semester November 1- April 30, by 5 pm on the third to the last Business day of October of each Year;
- for the semester May 1 - October 31, by 5 pm on the third to the last Business day of April of each Year;

Within three Business days of the receipt of the subscription request form, the Operating Company will provide access to information on Flexibility Service availability.

a.2) Availability and allocation method:

The Operating Company publishes the Monthly Redelivery Program/Adjusted Monthly Redelivery Program/ Spot Redelivery Program/ Adjusted Spot Redelivery Program proposals for the Day D+1 on the Electronic Communication System and in the dedicated portal by 1 pm on Day D, expressed in energy using a reference Gross Heating Value, in increase and/or decrease ("Redelivery Program Variation"). The Redelivery Program Variation also indicates the limits within which the Compensation period ("PdC") can be defined by the User meaning the times and

Courtesy translation, not binding.

quantities to compensate the proposed increase or decrease in the Month. These limits will be expressed by the Operating Company in terms of maximum number of days and minimum and maximum daily volumes. The PdC will be updated by the Operating Company at the end of the Redelivery Program Variation allocation process.

Two sessions are foreseen to meet the Program Variation requests:

- Session 1 : Redelivery Program Variation requests from Users must be sent by 4:30 pm via the dedicated portal according to the methods described in the Electronic Communication System.

Based on the received Redelivery Program Variation requests, the Operating Company updates the Electronic Communication System by 5 pm.

- Session 2 for locational market offers managed by GME : Redelivery Program variation requests from Users must be sent by 7:00 pm via the dedicated portal according to the methods described in the Electronic Communication System.

The request must contain the User's company name, the name of the User's legal representative duly authorized to send the request, the session (session 1 or session 2), the Day D+1 for which the request is made, the quantity in increase or decrease requested in the Redelivery Program Variation published by the Operating Company in the Electronic Communication System for the session for which the request is made and the indication of the requested PdC (consistent with the limitations previously published by the Operating Company). Except for unexpected events, any change made by the Operating Company to the PdC requested by the User must be justified.

Any addition by the User to the Monthly Redelivery Program and/or Adjusted Monthly Redelivery Program and/or Spot Redelivery Program and/or Adjusted Spot Redelivery Program change proposal for the Day D+1 formulated by the Operating Company invalidates the request.

By formulating a request, fully binding, the User irrevocably agrees:

- (i) to pay the Operating Company the Fees for the Flexibility Service, allocated by the Operating Company, as of Chapter III, article 8 paragraph 1.1 point (j), including any transportation capacity costs necessary to provide the Flexibility Service and other fees stated in Chapter III, article 8, paragraph 1.1 point (i); and
- (ii) to accept the Adjusted Monthly Redelivery Program change, following the request for additional services, Adjusted Spot Redelivery Program following the request for additional services accordingly. For session 2, the Redelivery Program will only and exclusively be actually changed following the communication to the Operating Company by Snam Rete Gas of the acceptance of the User's offer on the locational market by 8:30 pm on Day D. In lack of communication by Snam Rete Gas, the Redelivery Program will not be changed. If the User's offer is not accepted on the locational market, the CRF and CAS fees are not due, but the agreement to pay the CSS fee is irrevocable.

In the event the Operating Company receives:

- Several requests from the same User in the same session, the sole last request will be taken into account;
- Several requests from several Users in the same session whose total exceeds the Redelivery Program changes offered by the Operating Company, the Operating Company shall allocate the Redelivery Program Changes to each User in proportion to the quantities set in the Redelivery in the most recent Monthly Redelivery Program/Adjusted Monthly Redelivery Program and/or Spot Redelivery Program/ Adjusted Spot Redelivery Program

Courtesy translation, not binding.

and in the most recent Adjusted Monthly Redelivery Program following requests for additional services and/or Adjusted Spot Redelivery Program following requests for additional services accordingly for Day D+1, taking the User's request into account.

Except for the provisions in the Regasification Code concerning unexpected events, the Operating Company shall inform Users:

- of the allocation process results for Session 1 by 5 pm on Day D, combined with the Adjusted Monthly Redelivery Program following requests for additional services/Adjusted Monthly Redelivery Program following requests for additional services, accordingly;
- of the allocation process results for Session 2 by 7:30 pm on Day D;
- any change to the Adjusted Monthly Redelivery Program/Adjusted Spot Redelivery Program following requests for additional services accordingly, regarding Session 2 by 9:30 pm on Day G.

Except for events of Force Majeure, in the event the Adjusted Monthly Redelivery Program following requests for additional services/Adjusted Spot Redelivery Program following requests for additional services as communicated by the results of Session 1 or, for Session 2, by 9:30 pm accordingly is not met by the Operating Company, the User is not bound to pay the CAS fees and, proportionately, the CRF.

b) Temporary Storage Service

The Temporary Storage Service requires the Operating Company makes a Temporary LNG Storage Service and subsequent Redelivery available to the Users.

To access the Temporary Storage Service, annual and/or semi-annual and/or monthly products must be subscribed to for the Flexibility Service indicated in article a.1).

b.1) Availability and allocation method.

As soon as it is established that Temporary Storage Service is available³⁷, the Operating Company shall publish the available temporary storage capacity on the Electronic Communication System and in the dedicated portal meaning the volumes in Temporary Storage, the number of Days in Temporary Storage and the maximum Redelivery Gas quantity for each Day (“Volumes in Redelivery from Temporary Storage”).

Temporary Storage Service requests must be sent by Users by 5 pm on the third Business Day before the start of the requested Temporary Storage Service according to the methods described on the Electronic Communication System.

Request must contain the User's company name, the name of the User's legal representative duly authorised to make the request, the requested Temporary Storage volumes and number of requested Temporary Storage Days within the maximum Temporary Storage Service limit published by the Operating Company on the Electronic Communication System.

Any addition by the User to the Monthly Redelivery Program and/or Adjusted Monthly Redelivery Program and/or Spot Redelivery Program and/or Adjusted Spot Redelivery Program change proposal for the day D+1 formulated by the Operating Company invalidates the request.

³⁷ It is understood that making Temporary Storage Service available will not interfere nor effect actual Spot Capacity allocation.

Courtesy translation, not binding.

By formulating a request, fully binding, the User irrevocably agrees:

- (i) to pay the Operating Company the Fees for the Temporary Storage Service, allocated by the Operating Company, stated in Chapter III, article 8 paragraph 1.1 point (j), including any transportation capacity costs necessary to render Temporary Storage Service and other fees stated in Chapter III, article 8, paragraph 1.1 point (i); and
- (ii) to accept the Adjusted Monthly Redelivery Program change, following the request for additional services and/or Adjusted Spot Redelivery Program following the request for additional services accordingly, should the Temporary Storage Service be used.

In the event the Operating Company receives:

- Several requests from the same User within the deadline on the same Day, the sole last request will be taken into account;
- Several requests from several Users whose total exceeds the Temporary Storage Service offered by the Operating Company, the Operating Company shall allocate the Temporary Storage Service to each User in proportion to the quantities set in the Redelivery in the most recent Monthly Redelivery Program/Adjusted Monthly Redelivery Program and/or Spot Redelivery Program/Adjusted Spot Redelivery Program and in the most recent Adjusted Monthly Redelivery Program following requests for additional services and/or Adjusted Spot Redelivery Program following requests for additional services accordingly.

The Operating Company shall inform Users who requested Temporary Storage Service of the results of the allocation process by 12 am of the second Business Day prior to the start of requested Temporary Storage Service. Except for events of Force Majeure, if the Adjusted Monthly Redelivery Program or, accordingly, Adjusted Spot Redelivery Program following requests for Temporary Storage service is not met by the Operating Company, the User is not bound to pay the CAS, CBO and CRS fees.

b.2) Temporary Storage Service distribution conditions.

The request for Volumes in Redelivery from Temporary Storage under the Temporary Storage Service must be received by the Operating Company by 5 pm on the second Business Day prior to the Redelivery Day via a dedicated portal as described on the Electronic Communication System.

The request must contain the Redelivery Days, Redelivery Volumes, company name and name of the User's legal representative duly authorised to make the Redelivery request.

The Operating Company shall inform Users of the Adjusted Monthly Redelivery Program following requests for additional service/Adjusted Spot Redelivery Program following requests for additional service accordingly by 12 am on the Business Day prior to the Redelivery Day.

If, at the end of allocated Temporary Storage Service, the User did not request the Redelivery of all or part of the Volumes in Temporary Storage, the Operating Company shall update the Adjusted Monthly Redelivery Program/Adjusted Spot Redelivery Program accordingly and Redeliver the remaining volumes in Temporary Storage following the methods stated in Annex (k).